

www.bmwpost.ru - JOIN US!!!

Repair Manual



R 850 C
R 1200 C

BMW AG Motorcycle Division
After Sales

Published by: © BMW AG Motorcycle Division
After Sales
UX-VS-2

All rights reserved. Not to be reprinted, translated or duplicated either wholly or in part without prior written permission.
Errors and omissions excepted; subject to technical amendment.

Printed in Germany 3/99

Order number 01 50 7 654 051

Introduction

This repair manual will help you to perform all the main maintenance and repair work correctly and efficiently. It should be consulted regularly by workshop personnel as an addition to the practical and theoretical knowledge obtained in Training School courses. It is a contribution towards achieving even higher Service quality.

A new issue of this repair manual will be published if amendments or additions (supplements) are needed. The latest issue date is shown in the header of the microfiche. Microfiches rendered invalid by the new issue should be destroyed without delay.

All information in both text and illustrations refers to motorcycles in standard condition or with Original BMW accessories installed, and not to motorcycles which have been modified in any way to depart from the manufacturer's specification.

- The repair manual is structured in the logical sequence of the work to be performed: Removal, Dismantling, Repair, Assembly, Installation.
- The entire contents are divided into individual chapters, corresponding to the Construction Groups.

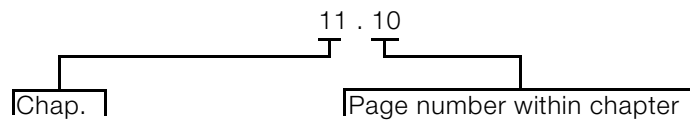

- Work to be performed during an Inspection is described in Group 00. The various Inspection routines are numbered I, II, III and IV. This numbering is repeated in the work descriptions which follow, so that work can take place without interruption.
- Use of the BMW special tools needed for certain tasks is described in the work instructions.

If the need arises, repair instructions are also issued in the form of Service Information. This information is of course incorporated into the next issue of the repair manual. We also recommend you to consult the detailed illustrations on the Parts microfiches as an additional source of information.

BMW AG Motorcycle Division
After Sales

Published by: BMW AG Sparte Motorrad
 Hufelandstr. 6
 D - 80937 München

All rights reserved. Not to be reprinted, translated or duplicated either wholly or in part without prior written permission.
Errors and omissions excepted; subject to technical amendment.
Produced in Germany

BMW AG Motorcycle Division

Maintenance schedule

R 1100 S / R 850/1200 C / R 1150 GS



Customer _____ Licence plate No. _____		BMW Inspection at 1000 km (600 miles)	BMW Service every 10 000 km (6 000 miles)	BMW Inspection every 20 000 km (12 000 miles)	BMW Annual Service
Order No. _____ Mechanic's signature _____					
Read the fault code memory with the MoDiTeC		<input type="checkbox"/>	<input type="checkbox"/>	<input type="checkbox"/>	<input type="checkbox"/>
Change oil while at regular operating temperature and renew the oil filter element if motorcycle is used only for short journeys or at outside temperatures under 0°C (32 °F), every 3 months, but at least every 3 000 km (1 800 miles) *)		<input type="checkbox"/>	<input type="checkbox"/>	<input type="checkbox"/>	<input type="checkbox"/>
Change oil in gearbox while at operating temperature at least every 2 years*)				<input type="checkbox"/>	<input type="checkbox"/> every 2 years
Change oil in rear wheel drive while at regular operating temperature; if necessary, clean inductive sensor on rear wheel every 40 000 km (24 000 miles) or at least every 2 years *)		<input type="checkbox"/>		<input type="checkbox"/>	<input type="checkbox"/> every 2 years
Renew fuel filter *) normally every 40 000 km (24 000 miles), if fuel quality is poor every 20 000 km (12 000 miles)				<input type="checkbox"/>	
Check battery acid level, if necessary add distilled water Clean and grease the battery terminals, if necessary				<input type="checkbox"/>	<input type="checkbox"/>
Renew intake air filter element in very dusty or dirty operating conditions, renew the intake air filter element every 10 000 km (6 000 miles) or even more often if necessary *)				<input type="checkbox"/>	
Renew Poly-V belt *) renew Poly-V belt every 60 000 km (36 000 miles); do not adjust				<input type="checkbox"/>	
Check brake fluid level at front and rear and top up if necessary *)		<input type="checkbox"/>	<input type="checkbox"/>	<input type="checkbox"/>	
Check operation of brake system and freedom from leaks; repair/replace items if nec. *)				<input type="checkbox"/>	
Examine brake pads and discs for wear, renew if necessary *)			<input type="checkbox"/>	<input type="checkbox"/>	
Change the brake fluid annually					<input type="checkbox"/>
Check clutch fluid level		<input type="checkbox"/>	<input type="checkbox"/>	<input type="checkbox"/>	
Change the clutch fluid every 40 000 km (24 000 miles) or at least every 2 years *)				<input type="checkbox"/>	<input type="checkbox"/> every 2 years
Check tightness of rear wheel studs		<input type="checkbox"/>			
Check rear wheel bearing play by tilting wheel				<input type="checkbox"/>	
Check swinging arm bearings (zero play); adjust if necessary *)		<input type="checkbox"/>		<input type="checkbox"/>	
Grease the side stand pivot		<input type="checkbox"/>	<input type="checkbox"/>	<input type="checkbox"/>	
Check function of side stand contact switch		<input type="checkbox"/>	<input type="checkbox"/>	<input type="checkbox"/>	<input type="checkbox"/>
Check condition of spark plugs			<input type="checkbox"/>		
Renew spark plugs *)				<input type="checkbox"/>	
Check security of cylinder head nuts		<input type="checkbox"/>			
Check/adjust valve clearances		<input type="checkbox"/>	<input type="checkbox"/>	<input type="checkbox"/>	
Check throttle cable for free movement, abrasion and kinking; renew if necessary *) Check cable play Check synchronisation and eliminate leaks *)		<input type="checkbox"/>	<input type="checkbox"/>	<input type="checkbox"/>	
Final inspection with road safety and functional check: – Condition of tyres and wheels, rims and spokes if applicable, tyre pressures – Lights and signalling equipment – Telltale and warning lights – Clutch, gear shift – Front and rear brakes, steering – Instruments – If necessary, test ride		<input type="checkbox"/>	<input type="checkbox"/>	<input type="checkbox"/>	<input type="checkbox"/>

*) **Charged as an additional item**

BMW AG Motorcycle Division

Pre-delivery check

R 1100 S / R 850/1200 C / R 1150 GS



<p>_____</p> <p>Customer</p>	<p>_____</p> <p>Licence plate No.</p>	<p>BMW Pre-delivery check</p>
<p>_____</p> <p>Order No.</p>	<p>_____</p> <p>Mechanic's signature</p>	
<p>Check the shipping crate for damage</p>		<input type="checkbox"/>
<p>Motorcycle:</p> <ul style="list-style-type: none"> - unpack - install remaining items - inspect for damage - check that delivery is complete: <ul style="list-style-type: none"> tools documentation keys correct optional extras 		<input type="checkbox"/>
<p>Fill and charge the battery (mark with charging date)</p>		<input type="checkbox"/>
<p>Check engine oil level when cold; add oil if necessary</p>		<input type="checkbox"/>
<p>Check clutch operating fluid level and brake fluid levels at front and rear</p>		<input type="checkbox"/>
<p>Check headlight beam angle, adjust if necessary</p>		<input type="checkbox"/>
<p>Check security of rear wheel studs (comply with correct tightening torque)</p>		<input type="checkbox"/>
<p>Check tyre pressures</p>		<input type="checkbox"/>
<p>Fill fuel tank</p>		<input type="checkbox"/>
<p>Final inspection as functional check:</p> <ul style="list-style-type: none"> - Clutch, gear shift - Front and rear brakes - Lights and signalling equipment, telltale and warning lights, instruments - Check operation of optional extras, ABS - If necessary, test ride 		<input type="checkbox"/>
<p>Confirm pre-delivery check in Service and Technical Booklet</p>		<input type="checkbox"/>
<p>Final cleaning</p>		<input type="checkbox"/>
<p>Motorcycle handed over on:</p>		

Contents

Group / Chapter

00 Maintenance and general instructions



11 Motor

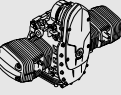

12 Engine electrics

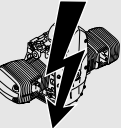

13 Fuel preparation and control

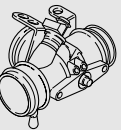

16 Fuel tank and lines



18 Exhaust system



21 Clutch

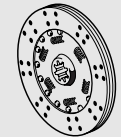

23 Gearbox



31 Front fork

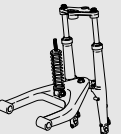

32 Steering



33 Rear wheel drive



Group / Chapter

34 Brakes

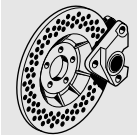

36 Wheels and tyres

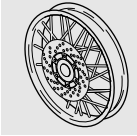

46 Frame



51 Equipment



52 Seat



61 General electrical equipment



62 Instruments



63 Lights



00 Maintenance and general instructions



Contents	Page
Tightening torques	3
Table of operating fluids	9
Key to maintenance intervals	11
Reading out MoDiTeC fault memory	11
(Inspections I, II, III and IV)	
Checking throttle cable play, adjusting if necessary	11
(Inspections I and III)	
Changing engine oil, renew oil filter element	12
(Inspections I, II, III and IV)	
Changing oil in gearbox	13
(Inspections III and IV) or at least every 2 years	
Changing oil in rear wheel drive; cleaning inductive signal transmitter at rear wheel	13
(Inspections I, III and IV) Every 40 000 km (24 000 miles) or at least every 2 years	
Renewing fuel filter	14
(Inspection III) In normal operating conditions every 40 000 km (24 000 miles); if fuel quality is poor every 20 000 km (12 000 miles)	
Checking battery acid level/topping up if necessary, cleaning/greasing battery posts	16
(Inspections III and IV)	
Renewing intake air cleaner element	16
(Inspection III) In very dirty and dusty operating conditions, renew every 10 000 km (6 000 miles) or even more frequently if necessary	
Renewing Poly-V belt	17
(every 60 000 km/36 000 miles) (Inspection III) Poly-V belt adjusting procedure:	
Checking brake fluid level	18
Front brake	



Rear brake	
Checking brake pads and discs for wear/renewing (Inspections II and III)	19
Checking front brake pad wear	19
Checking rear brake pad wear	19
Checking brake disc wear	19
Renewing brake pads Front brake	20
Renewing brake pads Rear brake	20
Renewing brake fluid and bleeding brake system	21
Renew the brake fluid annually (Inspection IV) [ABS Inspection II and III]	
Bleeding front brake circuit/renewing brake fluid Additionally with [ABS]	21
Bleeding rear brake circuit/renewing brake fluid Additionally with [ABS]	23
Checking clutch operating fluid level	24
(Inspections I, II and III)	
Checking tightness of rear wheel studs	25
(Inspection I)	
Checking rear wheel bearing play by tilting wheel	25
(Inspection III)	
Checking swinging arm bearings, adjusting if necessary	25
(Inspections I and III)	
Greasing the side (prop) stand pivot	25
(Inspections I, II and III)	
Checking function of side (prop) stand contact switch	25
(Inspections I, II, III and IV)	
Tightening cylinder heads	26
(Inspection I)	
Checking/adjusting valve operating clearances	26
(Inspections I, II and III)	
Checking/renewing spark plugs	27
(Inspection II)/renewing (Inspection III)	
Check synchronising	27
(Inspections I, II and III)	
Final inspection with road safety and functional check	28
(Inspections I, II, III and IV) Road safety check Roadworthiness check	

Tightening torques

Model	R 850/1200 C
Connection	Nm
11 Engine	
Cylinder head	
Tightening sequence:	
1. Tighten cylinder head nuts (oiled) crosswise	
1.1 Tighten all nuts to correct torque for joint	20
1.2 Tighten all nuts to correct angle	90°
1.3 Tighten all nuts to correct angle	90°
2. M 10 bolt	40
3. M 6 screw	9
After 1000 km (600 miles), tighten cylinder head nuts crosswise:	
1. Unfasten one nut	
2. Tighten one nut to initial value	20
3. Tighten nut to wrench angle	180°
4. Unfasten/retighten M10 screw	40
Timing gear carrier to cylinder head	9
Bearing cap on rocker shaft	15
Locknut, valve adjusting screw	8
Cylinder head cover to cylinder head	9
Camshaft end cover to cylinder head	9
Air intake connection to cylinder head	9
Camshaft	
Chain sprocket to camshaft	65
Camshaft bearing cap	15
Rotary breather	
Vent line to alternator mount cover	
M 8 screw	20
Banjo screw	25
Alternator mount cover	
M 6 screw	9
M 8 screw	20
Auxiliary shaft	
Chain sprocket to crankshaft	10
Chainwheel to auxiliary shaft	70
Chain tensioner housing to engine block	9



Model	R 850/1200 C	
Connection	Nm	
11 Engine		
Oil filter		
Oil filter	11	
Oil drain plug	32	
Oil pump		
Mesh filter basket to engine block	9	
Oil pump cover	9	
Pressure relief valve	35	
Oil pressure switch	30	
Oil cooler		
Oil cooler pipe to engine block	10	
Cooling oil line - banjo screw with oil vent valve	25	
Oil cooler to frame	9	
Oil cooler return line to engine block	35	
Screw-in union for oil cooler connection at engine block	35 (clean threads and apply Loctite 603 to inner and outer threads and in the contact face area)	
Cylinders		
Tightening sequence:		
1. M 8 screw	20	
2. M 6 screw	9	
3. Chain guide rail pivot screw	18	
Timing chain		
Chain tensioner	32	
Connecting rod		
Big end cap	Joint torque	20
	Additional wrench angle	80°
Crankcase		
Tightening sequence:		
1. M10 screw (oiled)	45	
2. M 8 screw (oiled)	20	
3. M 6 screw	9	



Model	R 850/1200 C	
Connection	Nm	
12 Engine electrics		
Starter motor to engine	20	
Starter cover to housing	7	
Positive lead to starter motor	10	
Alternator to cover mount	20	
Tensioning and retaining strap at alternator	20	
Spacer at alternator	20	
Positive lead to alternator	15	
Belt pulley at alternator	50	
Belt pulley to crankshaft	50	
Poly-V belt preload	8	
Spark plug	20	
Ignition coil holder to frame	9	
13 Fuel preparation and control		
Oil temperature sensor to engine block	25	
Air temperature sensor to air cleaner cover	10	
16 Fuel tank and lines		
Fuel tank to rear frame	10	
18 Exhaust system		
Manifold to cylinder head	24	
Clip on muffler	55 (apply Never Seez to clip contact surface)	
Oxygen sensor (lambda probe) to muffler	45 (apply Never Seez to thread)	
21 Clutch		
Clutch housing	Joint torque Additional wrench angle	40 (oil screw threads lightly) 32°
Housing cover	12	
Slave cylinder to gearbox	9	
Clutch line to handlebar fitting	18	

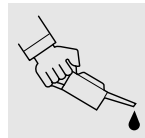

Model	R 850/1200 C	
Connection	Nm	
23 Transmission		
Oil filler plug		23
Oil drain plug		55
Gearbox to engine block		22
Gear shift pedal to rear frame		41
Selector lever to selector shaft		9
Gearbox cover to gearbox housing		9
31 Front fork		
Fixed tube to fork bridge		35 (free from oil and grease)
Slider tube bridge to slider tube		22 (clean thread + Loctite 243)
Quick-release axle clamp screws		20
Threaded journal to frame		130 (clean thread + Loctite 243)
Ball joint to fork slider bridge		230 (apply light coat of Never Seez to thread)
Leading link to ball joint		130 (clean thread + Loctite 2701)
Leading link to engine	right	73
Screw cap at leading link	left	42 (apply light coat of Never Seez to thread)
Spring strut to frame		40
Spring strut to leading link		40
32 Steering		
Handlebar at fork bridge		21 (apply light coat of Never Seez to thread)
Twistgrip to handlebar		8
33 Rear wheel drive		
Oil filler plug		23
Oil drain plug		23
Threaded ring		118 (Hylomar SQ 32 M)
Hexagon nut, input bevel gear		200 (clean thread + Loctite 2701)
Cover at rear-wheel drive housing		35
Rear-wheel drive to swinging arm		24
Swinging arm bearing journal to rear frame	right	9
Swinging arm bearing journal to rear frame	left	7 (clean thread + Loctite 2701)
Locknut at swinging arm bearing journal		160
Suspension strut to rear frame		50
Suspension strut to rear swinging arm		50

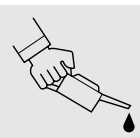

Model	R 850/1200 C
Connection	Nm
34 Brakes	
Brake caliper at fork slider tube	40
Brake caliper to rear wheel drive	40
Brake disc to front wheel	24 (clean thread + Loctite 2701)
34 Brakes	
Brake disc to rear wheel drive	21 (clean thread + Loctite 2701)
Master cylinder to footrest assembly	8
Brake pedal to footrest assembly	37
Brake lines/brake hose to brake components	18
ABS sensor	4 (handtight)
Front brake caliper bleed screw	7
Rear brake caliper bleed screw	4
Pressure modulator bleed screw	9
36 Wheels and tyres	
Quick-release axle clamp screws	20
Quick-release axle threaded connection	30
Rear wheel to rear wheel drive Screw wheel studs in handtight, then tighten in a crosswise pattern	
Initial tightening	50
Final tightening	105

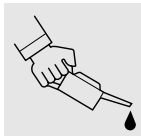

Model	R 850/1200 C
Connection	Nm
46 Frame	
Frame to engine M12 pin	82
M10 screw	58
Rear frame to engine	41
to gearbox	71
Side (prop) stand pivot mount to engine	21
Side (prop) stand to pivot mount	42 (clean thread + Loctite 243)
Footrest assembly to engine M12 screw	71
M8 screw	21
Pillion footrest holder to rear frame	21
Pillion seat mount	21
Mudguard to slider tube bridge	8
51 Equipment	
Mirrors	15
Ignition/steering lock to fork bridge	15 (shear bolt)
61 General electrical equipment	
Horn to holder	13
Ground (earth) strap to engine block	10
63 Lights	
Headlight to holder	15



Table of operating fluids

Item	Use	Order number	Quantity
Lubricant			
Optimoly MP 3	High-performance lubricating paste	07 55 9 062 476	100 g tube
Optimoly TA	High-temperature assembly paste	18 21 9 062 599	100 g tube
Silicone grease 300, heavy	Damping grease	07 58 9 058 193	10 g tube
Retinax EP2	Wheel, steering head and taper roller bearing grease	83 22 9 407 845	100 g tube
Contact spray	Contact spray	81 22 9 400 208	300 ml aerosol
Chain spray	Drive chain	72 60 2 316 676 72 60 2 316 667	50 ml spray 300 ml spray
Sealants			
3-Bond 1110 B	Surface sealant	07 58 9 056 998	5 g tube
3-Bond 1209	Surface sealant	07 58 9 062 376	30 g tube
omni VISC 1002	Surface sealant	07 58 1 465 170	90 g tube
Loctite 574	Surface sealant	81 22 9 407 301	50 ml tube
Curil K 2	Heat-conductive sealant	81 22 9 400 243	250 g can
Hylomar SQ 32 M	Permanently elastic sealant	81 22 9 400 339	100 g tube
Adhesives and retaining agents			
Loctite 648	Joint adhesive (low clearance)	07 58 9 067 732	5 g bottle
Loctite 638	Joint adhesive (greater clearance)	07 58 9 056 030	10 ml bottle
Loctite 243	Thread retainer, medium-strength	07 58 9 056 031	10 ml bottle
Loctite 270	Thread retainer, strong	81 22 9 400 086	10 ml bottle
Loctite 2701	Thread retainer, strong	33 17 2 331 095	10 ml bottle
Loctite 454	Cyanacrylate adhesive (gel)	07 58 9 062 157	20 g tube
Cleaner			
Brake cleaner	Brake cleaner	83 11 9 407 848	600 ml aerosol
Metal Polish	Polish for chromium plated parts	82 14 9 400 890	100 g tube
Testing agent			
Penetrant MR 68	Crack testing agent for aluminum housings	83 19 9 407 855	500 ml spray
Entwickler MR 70	Crack testing agent for aluminum housings	81 22 9 407 495	500 ml spray



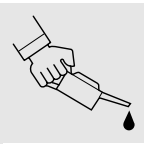

Key to maintenance intervals

- BMW Inspection 1000 km/600 miles **I**
- BMW Service **II**
- BMW Inspection **III**
- BMW Annual Service **IV**

Reading out MoDiTeC fault memory

(Inspections I, II, III and IV)

- Remove the left air cleaner trim panel.
- Connect MoDiTeC to diagnostic plug.
- Read out the fault memory.
- Perform any repair work indicated.

Checking throttle cable play, adjusting if necessary

(Inspections I and III)

- Check throttle cable for free movement and freedom from abrasion or kinking; renew if necessary.
- With the steering turned to various angles, open the throttle twistgrip fully and allow it to close again.
- When released, the twistgrip must return to the closed position by itself.

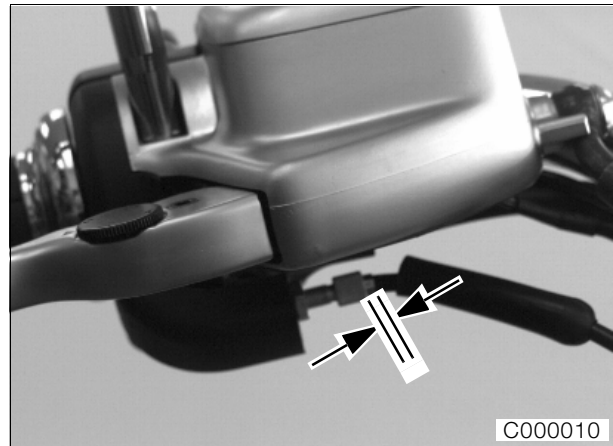

- Pull back the protective cap.
- Preset throttle cable play with the engine cold to 1.5 mm (0.06 in).
- Warm the engine up to its regular operating temperature.
- Adjust throttle cable play to 0.5 mm (0.02 in).

Adjusting value:

Initial throttle cable play setting

(engine cold) 1.5 mm (0.06 in)

Throttle cable play (engine warm) .. 0.5 mm (0.02 in)

Changing engine oil, renew oil filter element

(Inspections I, II, III and IV)



Note:

If the motorcycle is ridden only for short distances or outside temperatures are below 0°C (32°F): change the oil and renew the oil filter element every 3 months, but at least every 3 000 km (1 800 miles).

- Change the oil while it is at regular operating temperature.

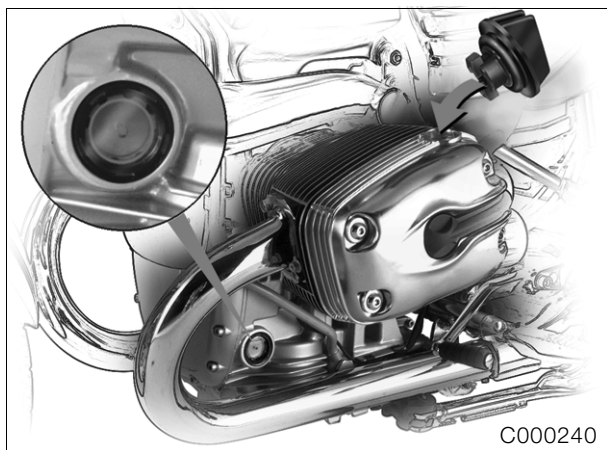

C000240

- Remove screw plug.

- Unscrew oil drain plug and drain off oil.
- Fit new seal and screw in drain plug.

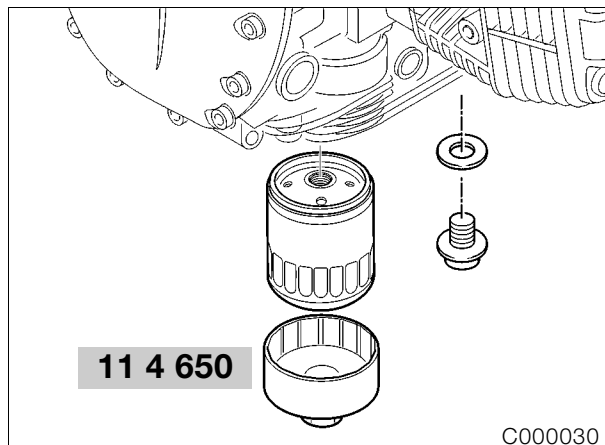

11 4 650

C000030

- Use oil filter wrench, **BMW No. 11 4 650**, to unscrew and remove the oil filter.
- Coat sealing ring on new oil filter element with oil and screw in.
- Add oil.
- Insert and tighten the screw plug.
- Check engine oil level with the motorcycle in a horizontal position; use the auxiliary stand, **BMW No. 00 1 550**.



Caution:

Never add engine oil above the MAX mark.



Tightening torque:

Oil filter.....	11 Nm
Oil drain plug.....	32 Nm

Fill quantity for engine:

With oil	
filter change ..	3.75 l (6.6 Imp. pints/3.96 US quarts)
Without oil	
filter change ..	3.50 l (6.2 Imp. pints/3.69 US quarts)
Oil volume between MIN and MAX marks.....	0.50 l (0.88 Imp. pint/0.52 US quart)

Engine oil grade:

Brand-name HD oil for four-stroke spark-ignition engine, API classifications SE, SF, SG; combination with CC or CD specification.

Changing oil in gearbox

(Inspections III and IV)
or at least every 2 years

- Change the gearbox oil while at regular operating temperature.

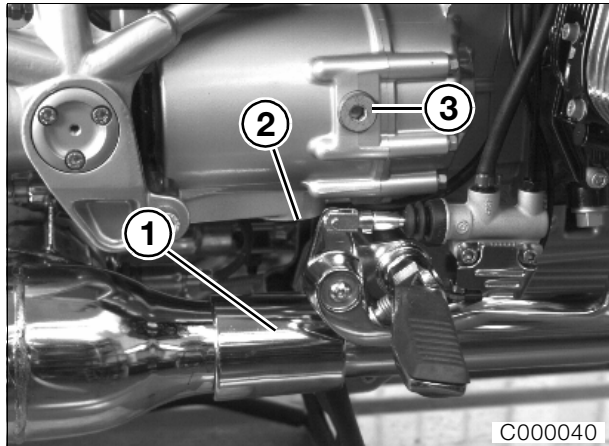

- Loosen clip/trim (1) at right silencer and turn downwards.
- Take out oil filler plug (3) and oil drain plug (2) and allow the oil to drain out.
- Clean the magnet in the oil drain plug.
- Insert the oil drain plug again.

Note:

Add oil to the gearbox up to the lower edge of the filler hole, then place the motorcycle on its side (prop) stand and add the remaining 0.2 litre (0.35 Imp. pint, 0.21 US quart).

- Add gearbox oil.
- Insert oil filler plug with new seal.

Tightening torque:

Oil drain plug 55 Nm
Oil filler plug 23 Nm
Exhaust pipe clip at silencer (muffler) 55 Nm

Fill quantity:

Initial filling 1.0 l (1.76 Imp. pints/1.06 US quart)
During
oil changes 1.0 l (1.76 Imp. pints/1.06 US quart)

Oil grade for gearbox:

Brand-name hypoid gear oil, SAE 90, API class GL 5

Changing oil in rear wheel drive; cleaning inductive signal transmitter at rear wheel

(Inspections I, III and IV)
Every 40 000 km (24 000 miles) or at least every
2 years

- Change the gearbox oil while at regular operating temperature.

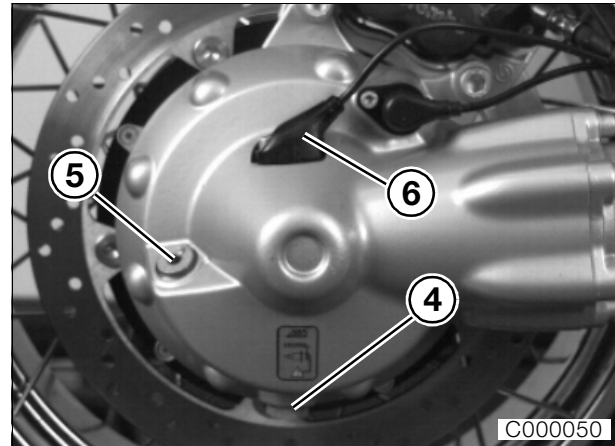

Caution:

Note that the interior of the gearbox is slightly pressurised.

- Slacken off oil drain plug (4) so that the pressure drops.
- Unscrew and remove oil filler plug (5).
- Unscrew and remove oil drain plug (4) and allow the oil to drain out.
- Fit new seal and screw in drain plug.
- Add gearbox oil.
- Insert oil filler plug with new seal.
- Release the fastening, pull out inductive signal transmitter (6) and clean it.

Tightening torque:

Oil drain plug 23 Nm
Oil filler plug 23 Nm

Fill quantity:

Initial filling up to lower edge of filler
hole app. 0.20 l (0.35 Imp. pint/0.21 US quart)
Oil change up to lower edge of filler
hole app. 0.20 l (0.35 Imp. pint/0.21 US quart)

Oil grade for rear wheel drive:

Brand-name hypoid gear oil, SAE 90, API class GL 5

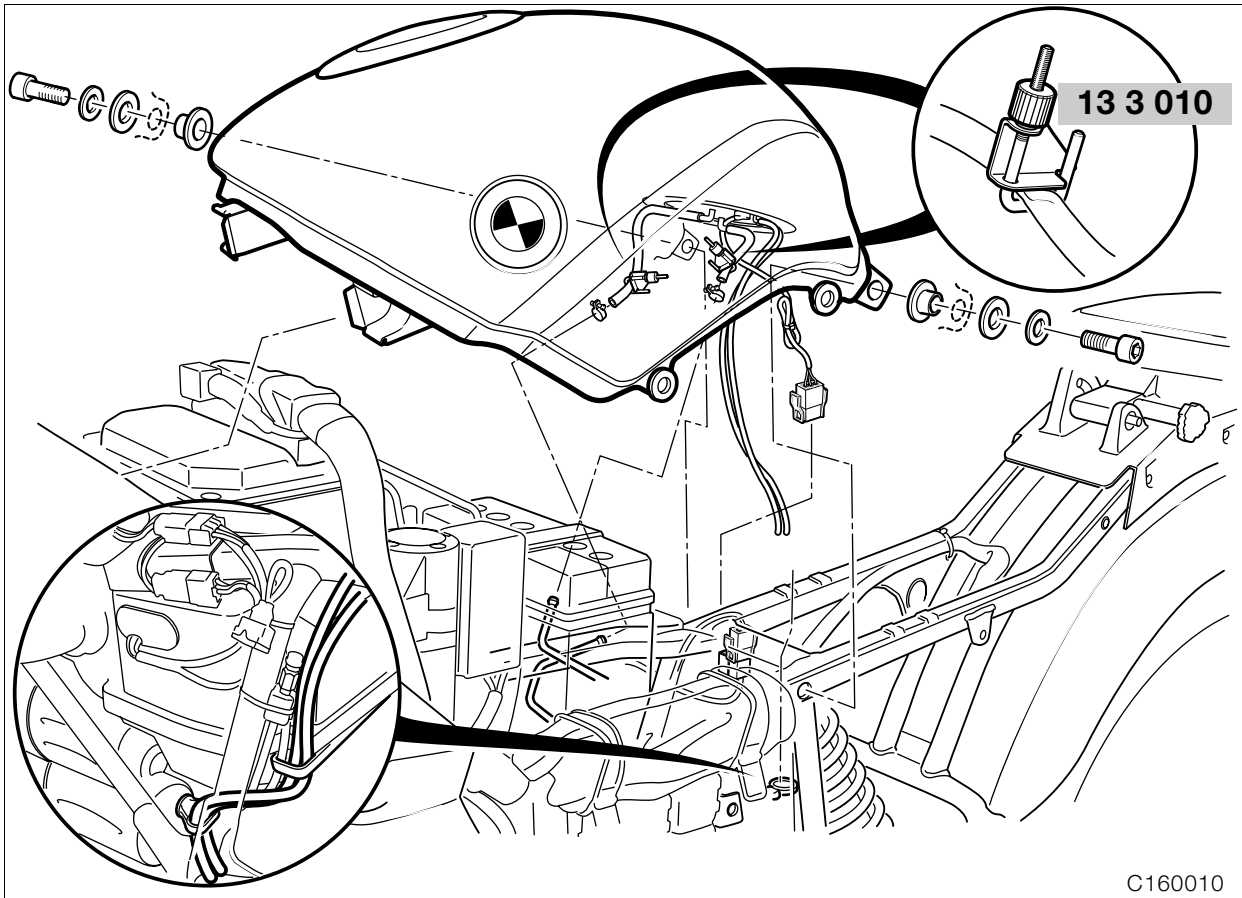

Renewing fuel filter

(Inspection III)

In normal operating conditions every 40 000 km (24 000 miles); if fuel quality is poor every 20 000 km (12 000 miles)

- Remove seat.
- Remove right air cleaner trim panel.
- Remove left and right trim panels.



Caution:

Fuel is flammable and a hazard to health. Observe relevant safety regulations.

- Take off the fuel tank.
- Seal the fuel feed and return lines with a hose clip, **BMW No. 13 3 010**, detach and pull off.

- Pull the plug connector off the fuel pump assembly.
- Lift off fuel tank.

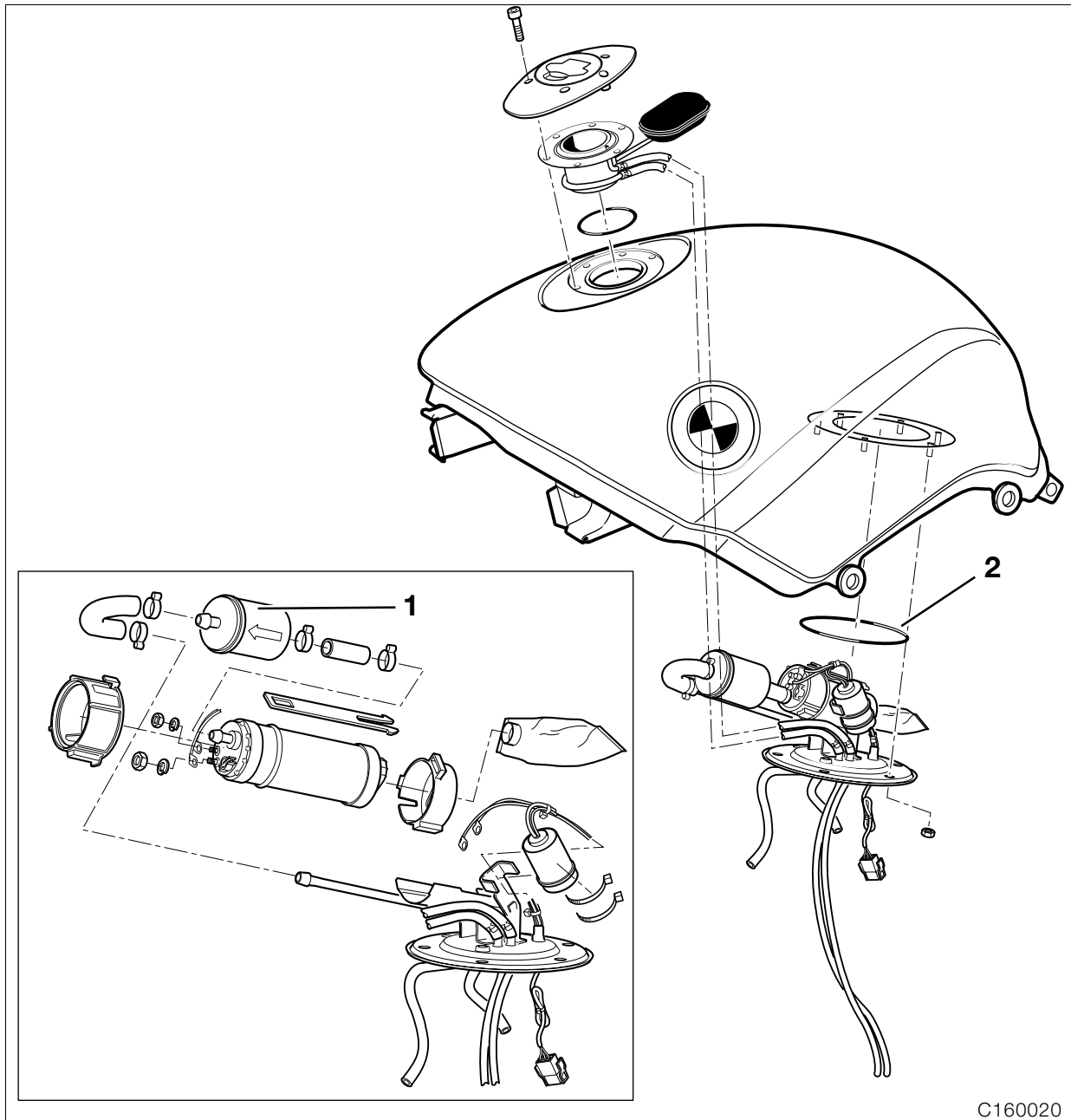

C160020

- Drain fuel tank.
- Remove fuel pump assembly.
- Detach hoses from fuel filter (1).

⚠ Caution:
 Note correct direction of flow through fuel filter.
 Use only an O-ring seal (2) in good condition.
 After installing, check fuel pump assembly for leaks.

- Fit new fuel filter.
- Secure non-reusable hose clips with pliers, **BMW No. 13 1 500.**

⚙ Tightening torque:
 Fuel pump unit 5 Nm

Installing:

📄 Note:
 Note correct path of vent lines.

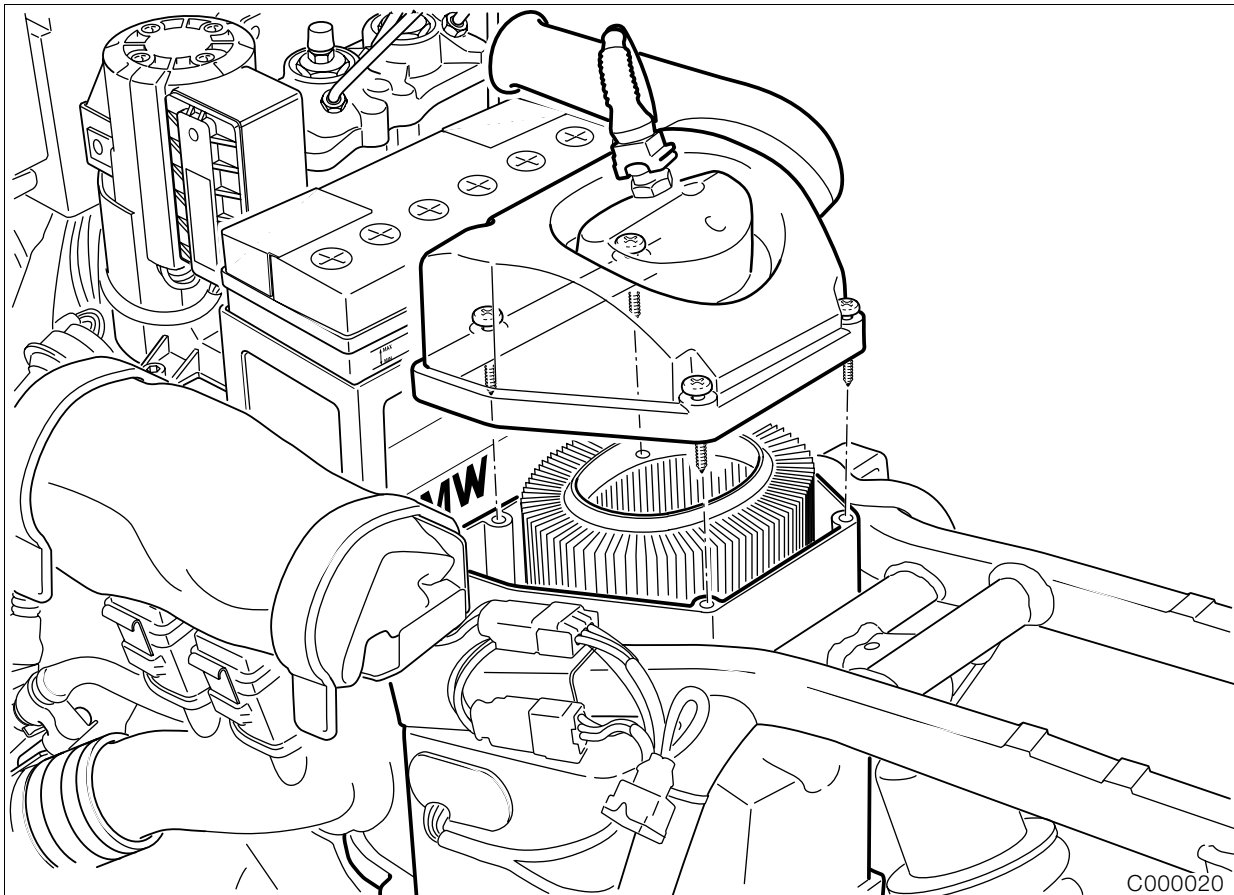

Checking battery acid level/topping up if necessary, cleaning/greasing battery posts

(Inspections III and IV)

- Release the rubber strap holding the battery.
- Raise the battery and check its acid level.
- Top up battery acid level with distilled water as far as the MAX mark.

Protective battery-post grease:e.g. Bosch Ft 40 V1

Renewing intake air cleaner element

(Inspection III)
In very dirty and dusty operating conditions, renew every 10 000 km (6 000 miles) or even more frequently if necessary

- Detach and raise the upper part of the air cleaner housing.
- Renew air cleaner element.
- Install the fuel tank.
- Note correct path of vent lines.
- Install the left/right trim panels.

 **Tightening torque:**
 Fuel tank to rear frame 10 Nm

Renewing Poly-V belt

(every 60 000 km/36 000 miles)

(Inspection III)

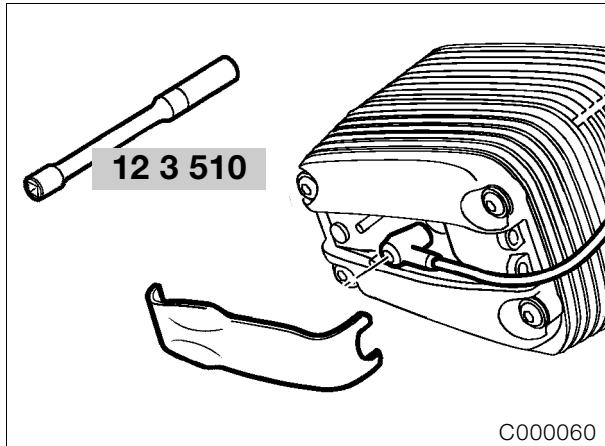

C000060

- Remove the cover.
- Use the spark plug cap assembly tool from the toolkit to pull off the spark plug caps.
- Use spark plug wrench, **BMW No. 12 3 510**, to unscrew and remove the spark plugs.

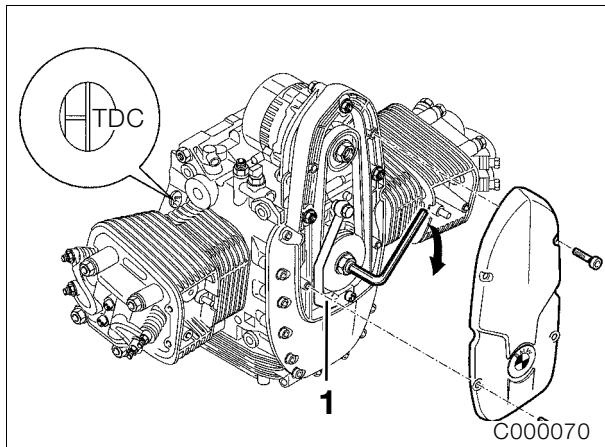

C000070

- Remove the horn with its mount.
- Remove front cover.
- Remove vent line (1).

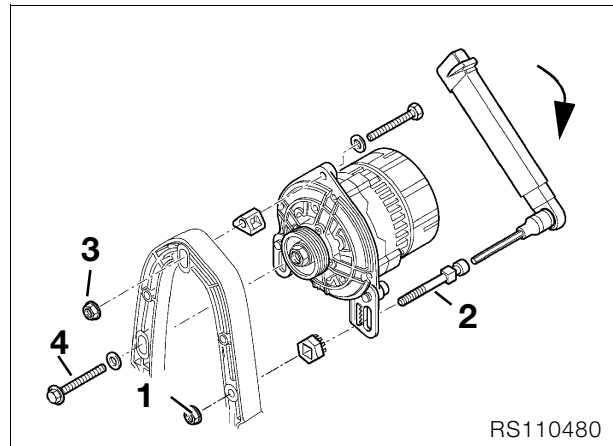

RS110480

- Slacken off alternator mounting screws (1,3,4) and install a new Poly-V belt if necessary.

Poly-V belt adjusting procedure:

Poly-V belt installation procedure:

- Place the Poly-V belt in position, tension it and turn the engine over once, then release belt tension.

Poly-V belt tensioning procedure:

1. Screw hex nut (1) on adjusting screw (2) up handtight (**no tools to be used**)
2. Tighten adjusting screw (2) with a torque wrench and keep it under tension.
3. Tighten upper retaining nut (3), then release the tension at the adjusting screw.
4. Tighten all screws and nuts.

Tightening torque:

Poly-V belt preload.....	8 Nm
Alternator to alternator support cover.....	20 Nm
Vent line at generator mount cover:	
Banjo screw	25 Nm
Machine screw	10 Nm

Caution:

Install the vent line with new O-ring seals.

Checking brake system for correct operation and freedom from leaks; repairing/renewing if necessary (Inspection III)

- Checking brake system for leaks.

Checking brake fluid level



Note:

The brake fluid volume (between MIN and MAX) is sufficient for the complete range of pad wear from new to the wear limit. It is not normally necessary to add fluid to compensate for pad wear. If the level drops below the minimum mark, this indicates some other fault.

(Inspections I, II and III)

Front brake

- Make sure that the specified setting (distance between handlebar and fuel tank 30-50 mm/ 1.2-2 in) is correct.
- Check with the motorcycle on its side (prop stand).
- Turn the handlebar fully to the left.
- The brake fluid must not drop below the minimum level 2 mm (0.08 in) below the ring mark (arrow).

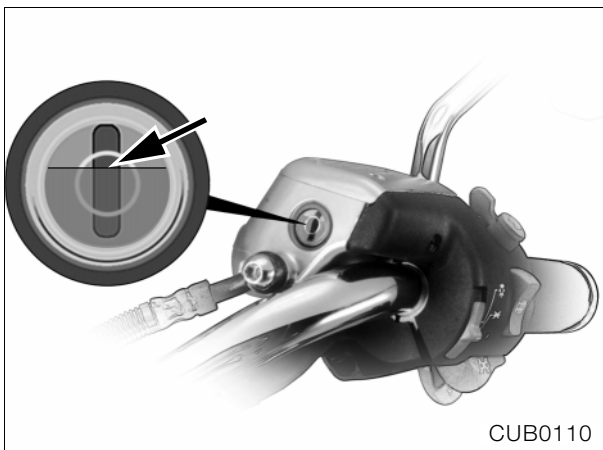

CUB0110

Brake fluid gradeDOT 4

Rear brake

- Position the motorcycle horizontally with auxiliary stand, **BMW No. 00 1 550**.
- Brake fluid must not drop below the minimum level (arrow).

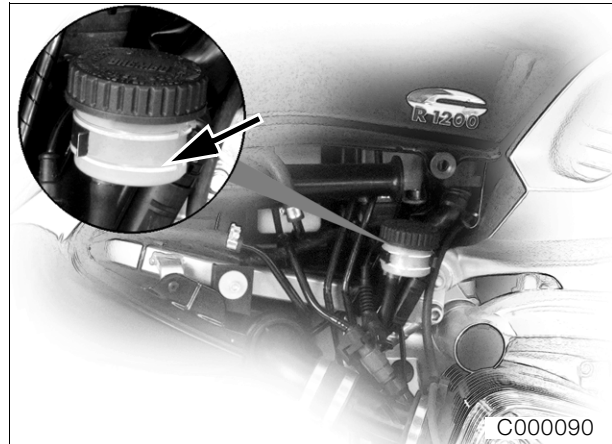

C000090

Brake fluid gradeDOT 4

Checking brake pads and discs for wear/renewing

(Inspections II and III)

Checking front brake pad wear

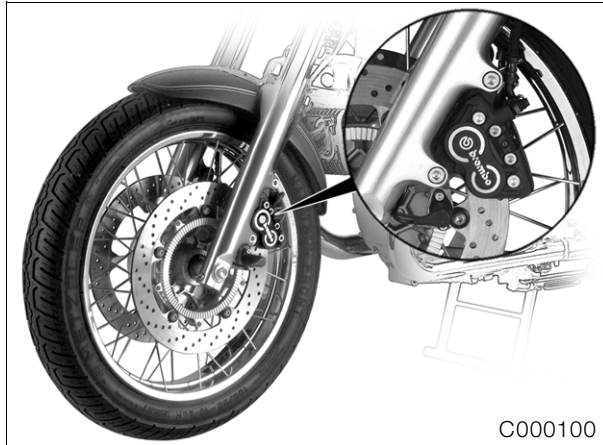

C000100

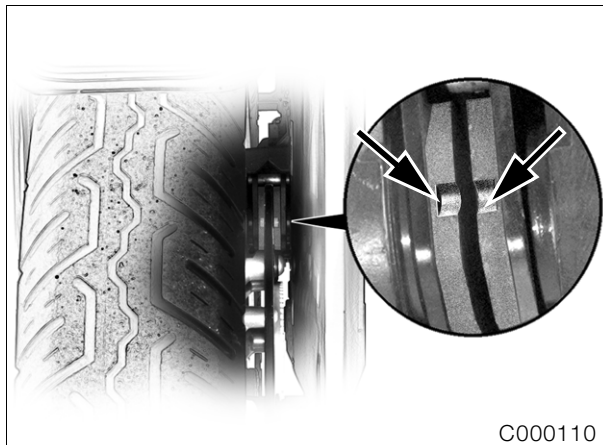

C000110

- Examine the wear limit marks (arrows).

Caution:

Brake pad thickness must not fall below the minimum value.
Change pads only as a complete set.

Minimum lining thickness: 1.5 mm (0.06 in)

Checking rear brake pad wear

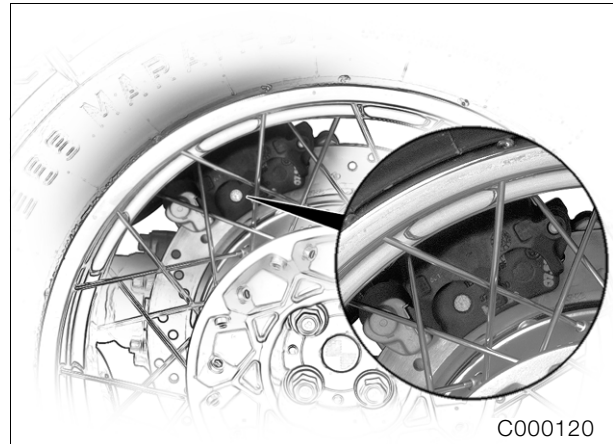

C000120

It should not be possible to see the brake disc through the hole (arrow) in the inner brake pad.

If the brake disc is visible, the wear limit has been reached and the pads must be renewed.

Checking brake disc wear



C000130

- Examine the brake discs carefully for cracks, damage, distortion, wear and score-marks.

Brake disc wear limit:

front:..... 4.5 mm (0.177 in)

rear:..... 4.6 mm (0.181 in)

Renewing brake pads Front brake

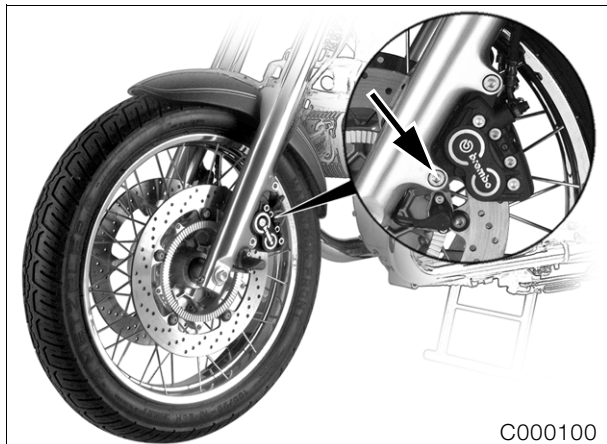

- Detach/remove brake caliper from mounting (arrow).

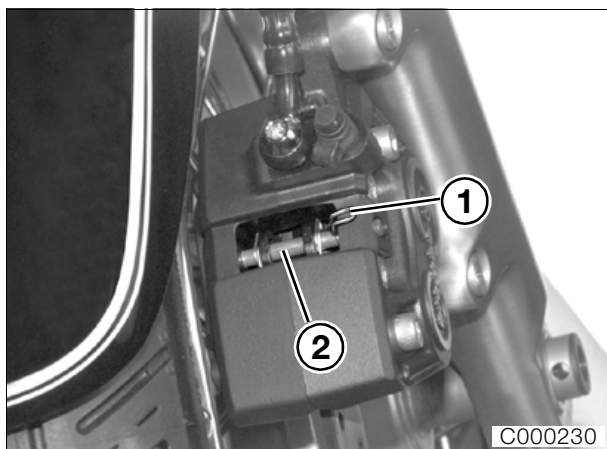

- Remove the split-pin keeper (1) from the retaining pin (2).
- Drive out retaining pin (2).
- Remove brake pads by pulling downwards.
- Install by following the above work instructions in the reverse order.
- Before installing the brake caliper, force the pistons fully back with resetting tool, **BMW No. 34 1 500**.

 **Tightening torque:**
Brake caliper at fork slider tube 40 Nm

Renewing brake pads Rear brake

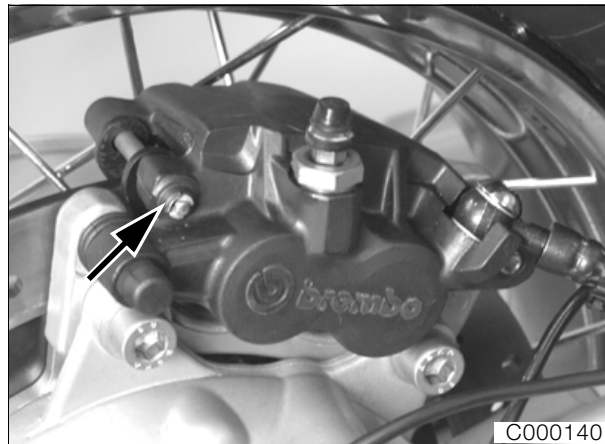

- Loosen the rear wheel.
- Unfasten/remove brake caliper.
- Remove circlip (arrow) at retaining pin.
- Drive the retaining pin out towards the wheel side.
- Remove brake pads.
- Install by following the above work instructions in the reverse order.
- Before installing the brake caliper, depress the piston fully.

 **Tightening torque:**
Brake caliper to rear wheel drive 40 Nm
Screw the rear wheel studs in handtight, then tighten them in a crosswise pattern.
Initial tightening 50 Nm
Final tightening 105 Nm

Renewing brake fluid and bleeding brake system

Renew the brake fluid annually (Inspection IV)

[ABS Inspection II and III]

Bleeding front brake circuit/renewing brake fluid



Note:

This description applies to brake filling and bleeding devices with vacuum extraction of the brake fluid at the brake caliper.

If other devices are used, comply with their manufacturers' instructions.

- Turn the steering to the left.



Caution:

When bleeding the brakes, always start on the **right** side.

- Take off the brake caliper.
- Remove the brake pads.

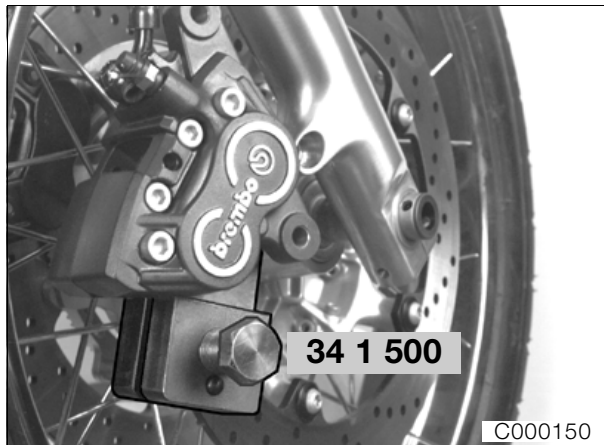

- Force the pistons fully back with resetting tool, **BMW No. 34 1 500**.



Caution:

Do not allow brake fluid to come into contact with painted parts of the motorcycle, because brake fluid destroys paint.

- Take off reservoir cover with rubber diaphragm.
- Release the right handlebar switch.
- Loosen the clamp screw for the handbrake fitting and turn the fitting until the brake fluid reservoir is horizontal.

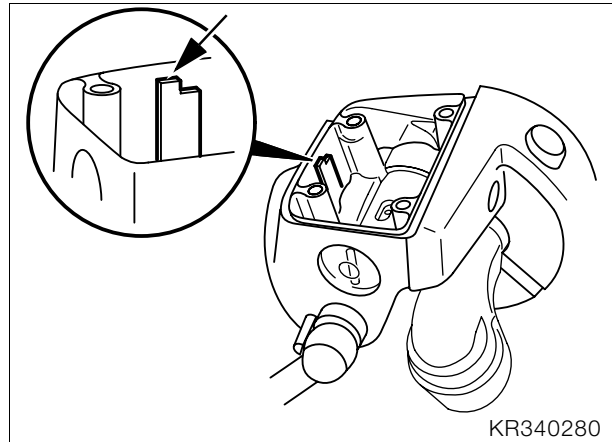

Caution:

When adding brake fluid, do not allow it to enter the holes for the reservoir lid screws.

- Add brake fluid up to the MAX mark (arrow).
- Connect the brake bleeding device to the bleed screw on the **right** brake caliper.
- Open the bleed screw by half a turn.
- Draw off brake fluid until it emerges clear and free from air bubbles.
- Close the bleed screw on the right brake caliper.
- Repeat the bleeding process at the left brake caliper.

When installing:



Note:

Clean the rim of the reservoir, the rubber gaiter and the cover to remove brake fluid, and re-assemble the components with great care.



Next check brake fluid level with the motorcycle on its side (prop) stand and the handlebar turned to the left, and ensure that no air bubbles are visible in the sight glass.

Additionally with [ABS]



- Connect the brake bleeding device to the pressure modulator for the **front brake** (arrow); this is marked **VR**.
- Open the bleed screw by half a turn.
- Draw off brake fluid until it emerges clear and free from air bubbles.
- Close the bleed screw.
- Bleed the **left** brake caliper in precisely the same way as on the right.
- If necessary, repeat the brake bleeding procedure at the right/left.

 **Tightening torque:**
 Bleed screw on pressure modulator..... 9 Nm

- Take out the resetting tool and insert spacer, **BMW No. 34 1 520**, in its place.
- Press the pistons back in the second brake caliper, but do not remove the resetting tool.
- Fill and bleed the front brake circuit.
- Installation takes place in the reverse order of removal.

Brake fluid gradeDOT 4

 **Tightening torque:**
 Brake caliper to fork tube 40 Nm
 Bleed screw at brake caliper 7 Nm

Bleeding rear brake circuit/renewing brake fluid



Note:

On motorcycles with ABS, start at the pressure modulator.

- Use the auxiliary stand, **BMW No. 00 1 550**.
- Loosen the rear wheel studs.
- Remove the cover for the line at the swinging arm.
- Take off the brake caliper.
- Remove the inner brake pad.



Caution:

Do not allow brake fluid to come into contact with painted parts of the motorcycle, because brake fluid destroys paint.



- Move the brake caliper to a horizontal position.
- Connect the bleed line and open the bleed screw.
- Force the pistons fully back with resetting tool, **BMW No. 34 1 500**.
- Press the brake pedal down several times until brake pressure is felt to build up.

- Fill the rear brake circuit and bleed it.
- Take off the reservoir cover.

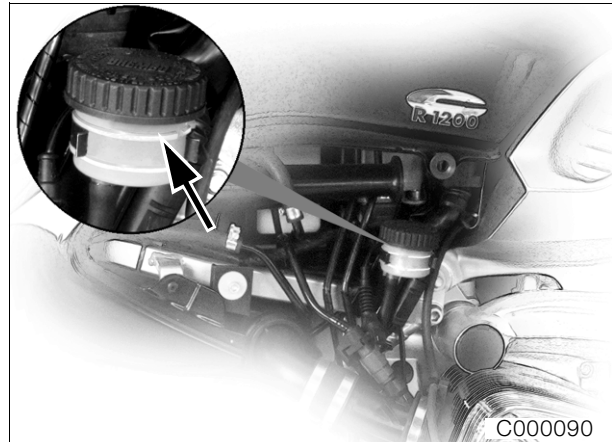

- Add brake fluid up to the MAX mark (arrow).
- Connect the brake bleeding device to the bleed screw on the brake caliper.
- Open the bleed screw by half a turn.



Caution:

During brake bleeding, make sure that the fluid replenishing hole is always below the level of the brake fluid, or else air will be drawn into the brake system. If this occurs, repeat the bleeding operation.

- Draw off brake fluid until it emerges clear and free from air bubbles.
- Close the bleed screw.
- Installation takes place in the reverse order of removal.



Tightening torque:

Brake caliper to rear wheel drive	40 Nm
Rear wheel to rear wheel drive	
Initial tightening	50 Nm
Final tightening	105 Nm
Bleed screw at brake caliper	4 Nm

Additionally with [ABS]

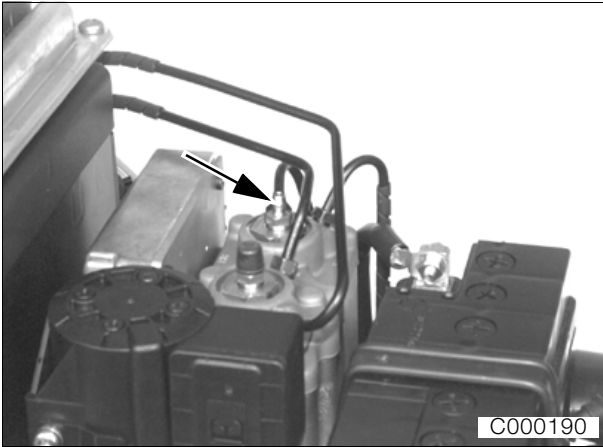

- Connect the brake bleeding device to the bleed screw on the pressure modulator for the **rear brake** (arrow); this is marked **HR**.
- Open the bleed screw by half a turn.

Caution:

During brake bleeding, make sure that the fluid replenishing hole is always below the level of the brake fluid, or else air will be drawn into the brake system. If this occurs, repeat the bleeding operation.

- Draw off brake fluid until it emerges clear and free from air bubbles.
- Close the bleed screw.
- If necessary, repeat the bleeding procedure.

Brake fluid gradeDOT 4

Tightening torque:

Bleed screw at pressure modulator..... 9 Nm

Checking clutch operating fluid level

(Inspections I, II and III)

Caution:

Do not allow brake fluid to come into contact with painted parts of the motorcycle, because brake fluid destroys paint.

- Place the motorcycle on the auxiliary stand, **BMW No. 00 1 550**.
- Turn the steering to the right.

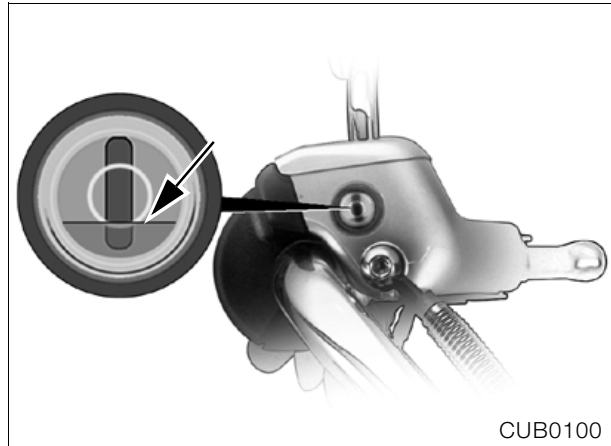

Caution:

With the clutch lining in new condition the surface of the fluid (arrow) must be up to the lower edge of the ring mark; it must **not be below** normal.

Note:

As the clutch lining wears, the fluid level in the reservoir rises.

- If necessary, take off reservoir cover with insert.
- Correct the fluid level. Mark in reservoir: as for brake circuit.
- Re-attach the reservoir cover with insert.
- Tighten the reservoir cover without using force.

Brake fluid gradeDOT 4

Checking tightness of rear wheel studs

(Inspection I)

- Tighten the rear wheel studs with a torque wrench.



Tightening torque:

Rear wheel studs 105 Nm

Checking rear wheel bearing play by tilting wheel

(Inspection III)

- Tilt the rear wheel to and fro across its axle.
- If play is detected, fit new shims to rear wheel drive or renew bearings.

Checking swinging arm bearings, adjusting if necessary

(Inspections I and III)

- Grip rear tyre and try to move it sideways, bracing against the frame.

Greasing the side (prop) stand pivot

(Inspections I, II and III)

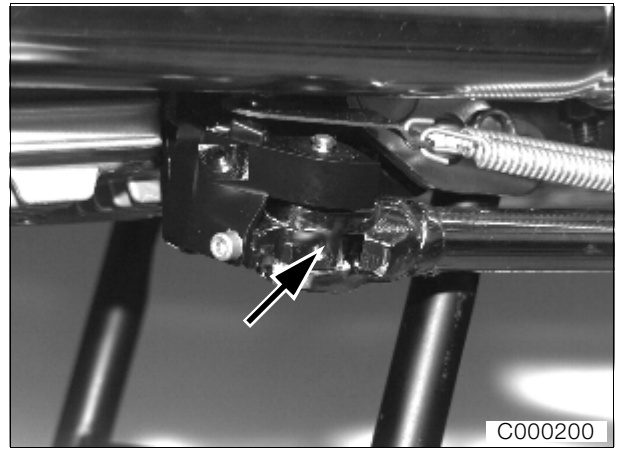

- Check free movement of side (prop) stand and grease if necessary.
- Grease pivot point (arrow).

Lubricant:

For side (prop) stand pivot..... Shell Retinax EP2

Checking function of side (prop) stand contact switch

(Inspections I, II, III and IV)

- Place the motorcycle on the auxiliary stand, **BMW No. 00 1 550**.
- Select a gear and switch on the ignition.
- Slowly extend the side (prop) stand and watch the neutral indicator light.



Note:

As the stand is extended, the neutral indicator light should come on briefly.

Tightening cylinder heads

(Inspection I)

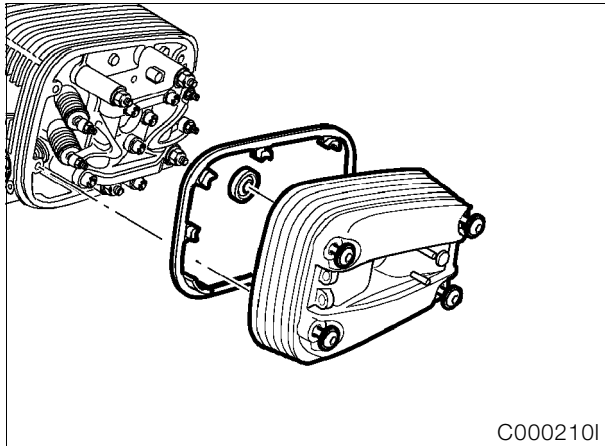

C0002101

- Remove cylinder head cover.



Caution:

Trap escaping oil.

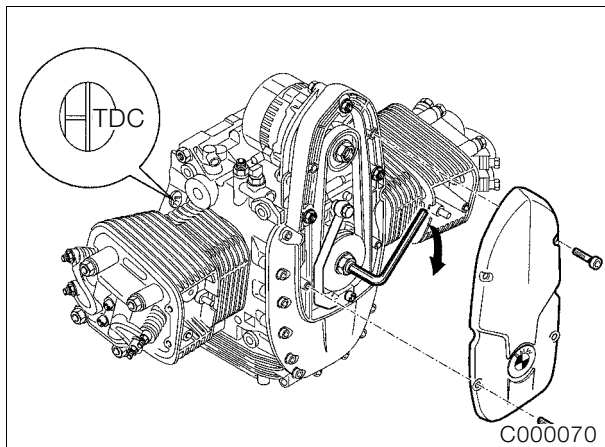

C000070

- Select a gear and turn the rear wheel, or set the piston to TDC on the ignition stroke by turning the belt pulley.

Top dead centre on ignition stroke:

- The OT (TDC) mark is visible and the inlet and exhaust valves in the cylinder concerned are closed.
- Tighten cylinder head nuts.

Tightening procedure after 1 000 km (600 miles)

- Tighten the cylinder head nuts one after the other in a crosswise pattern
 - Slacken off one nut at a time
 - Tighten nut to initial torque 20 Nm
 - Tighten nut to specified wrench angle 180°
- Unfasten/retighten M10 screw 40 Nm

Checking/adjusting valve operating clearances

(Inspections I, II and III)

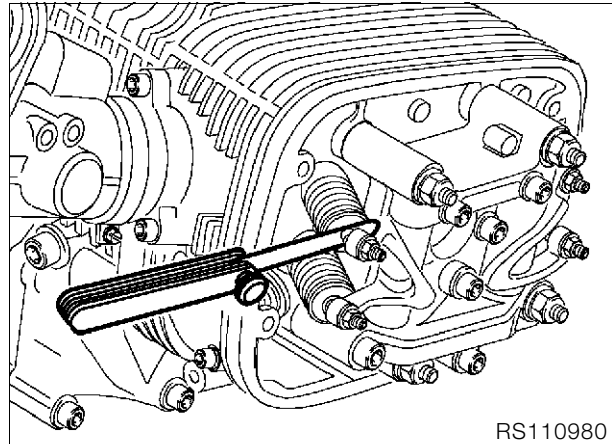

RS110980

- Check valve clearance with feeler gauge and, if necessary, correct with adjusting nut/lock.

Adjust valve clearances with the engine cold (max. 35 °C/95 °F):

Inlet 0.15 mm (0.006 in)
Exhaust 0.30 mm (0.012 in)



Tightening torque:

Locknut 8 Nm

- After adjusting, check valve operating clearances again; it should be possible to pull the correct feeler gauge through between the valve stem and the adjusting screw with only slight resistance.
- Assemble in reverse order.



Caution:

Make sure that gasket is correctly seated. Gaskets and sealing faces must be free from oil or grease.



Tightening torque:

Cylinder head cover 8 Nm

Checking/renewing spark plugs

(Inspection II)/renewing (Inspection III)

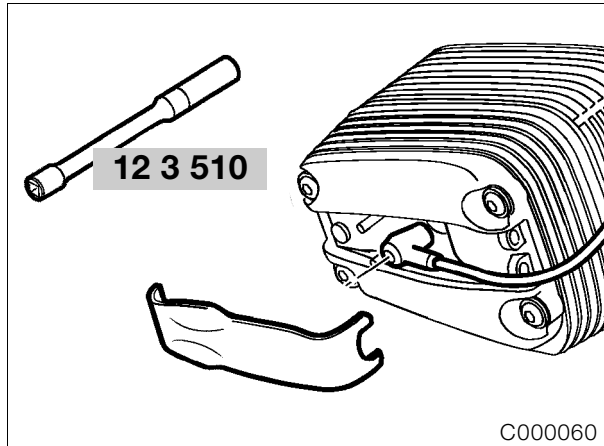

- Unscrew and remove spark plugs with the spark plug wrench, **BMW No. 12 3 510**.



Caution:

Do not bend electrodes - risk of breakage!

Electrode gap: 0.8 mm (0.031 in)

Gap wear limit: 1.0 mm (0.039 in)



Tightening torque:

Spark plug..... 20 Nm

Check synchronising

(Inspections I, II and III)

- The engine must be at regular operating temperature.

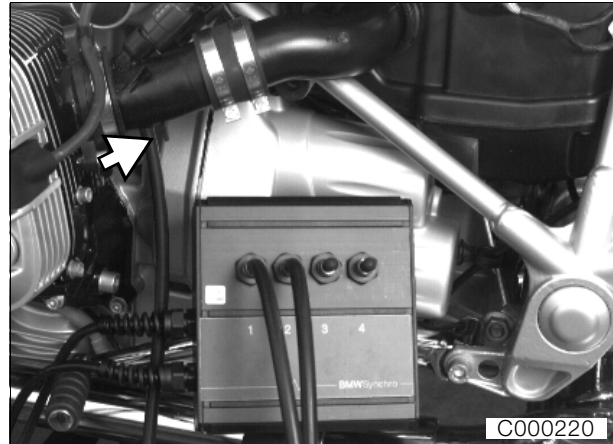

- Connect the **BMW Synchrotester** hose to the vacuum stub pipe (arrow) and the lines to the **MoDiTeC**.



Note:

If the left/right readings differ by more than 30 millibars (0.42 psi), check the air intake system for leaks.

Final inspection with road safety and functional check

(Inspections I, II, III and IV)

Road safety check

- Check wheels and tyres.
- Check/correct tyre pressures.
- Wait at least 10 minutes after the trial run/road test before checking/correcting engine oil level.



Tyre pressures:

Solo	front 2.2 bar (31.3 psi)
.....	rear 2.5 bar (35.6 psi)
With pillion passenger	front 2.5 bar (35.6 psi)
.....	rear 2.7 bar (38.4 psi)
With pillion passenger + luggage.....	front 2.5 bar (35.6 psi)
.....	rear 2.9 bar (41.2 psi)

Roadworthiness check

- Lights
- Telltale/warning lights
- Horn
- Instruments
- Special equipment
- Clutch
- Gear shift
- Steering
- Foot brake and handbrake
- Trial run if necessary

11 Motor

Contents

Page

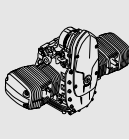

Technical data	5
Sectioned drawing of engine	11
Lubricating oil circuit	12
Coolant circuit	13
Removing engine	15
Dismantling engine	18
Removing cylinder head cover	19
Locking the engine in the TDC position	20
Top dead centre on ignition stroke:	20
Removing and installing chain tensioner	21
Assembly specification for timing chain tensioner:	21
Removing valve gear holder	22
Dismantling/reassembling valve gear holder	23
Removing cylinder head	25
Dismantling, checking, repairing and re-assembling cylinder head	26
Removing and installing valves	26
Removing valve stem seals	26
Checking valves for wear	27
Remachining valve seat	27
Checking and repairing cylinder head	27
Checking valve guide for wear	27
Replacing valve guides	28
Installing valve and valve stem seal	29
Removing cylinder barrel	30
Removing/dismantling piston	30
Checking pistons and cylinders	31
Assembling pistons	31
Removing/installing conrod	32
Removing and installing alternator cover with engine installed	33

Contents

Page

Removing alternator mount cover	33
Renewing radial shaft seal in alternator mount cover	34
Renewing radial shaft seal for rotary breather	34
Removing auxiliary shaft drive	35
Removing oil pump	36
Removing radial shaft seal on crankshaft with engine installed	37
Dismantling crankcase	38
Removing crankshaft, auxiliary shaft and timing chain tensioning and slide rails	40
Removing and installing oil pick-up basket	41
Replacing oil level sight glass	41
Removing conrods	41
Checking conrods	41
Measuring main and big end bearing play	42
Measuring radial bearing play	42
Installing main bearing	43
Measuring axial bearing play	43
Measuring big end bearing play	44
Assembling engine	45
Installing conrod	45
Installing crankshaft	46
Installing timing chain tensioning and slide rails	46
Installing auxiliary shaft/timing chains	46
Assembling engine block	47
Installing the crankshaft radial seal	49
Installing clutch housing	50
Installing oil pump	51
Installing auxiliary shaft drive	52
Installing piston	53
Installing cylinder	54
Installing cylinder head	55
Adjusting valve clearances	56

Installing right cylinder head57
Adjustment specification57

Installing left cylinder head58
Adjustment specification58

Installing alternator mount cover60

Installing magnetic gate/belt pulley60
Timing the ignition61

Installing alternator62

Installing engine63

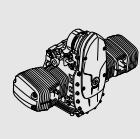

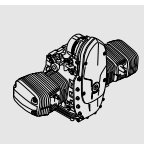

Technical data		R 850 C	R 1200 C
Engine, general			
Engine design		Four-stroke flat twin, air-cooled with oil-cooled exhaust ports, installed longitudinally, 4 valves per cylinder, two high-mounted camshafts, electronic fuel injection.	
Location of engine number		Crankcase	
Cylinder bore	mm (in)	87.5 (3.44)	101 (3.97)
Stroke	mm (in)	70.5 (2.77)	73 (2.87)
Effective displacement	cc	848	1170
Compression ratio		10.3 : 1	10.0 : 1
Power output	kW (bhp)/min ⁻¹	37 (50)/5250	45 (61)/5000
Max. torque	Nm/min ⁻¹	71/4750	98/3000
Permissible maximum engine speed	min ⁻¹	7000	
Idle speed	min ⁻¹	750 ⁺¹⁵⁰	
Direction of rotation		Clockwise, looking at ignition system	
Compression test pressure	bar (psi)		
good	bar (psi)	above	10 (142)
normal	bar (psi)		8.5...10 (121...142)
poor	bar (psi)	below	8.5 (121)
Intake port dia./cylinder head	mm (in)	45 (1.77)	
Lubrication system			
Theoretical volume in circulation at 6000 min ⁻¹			
Lubricating oil	l (Imp. gal/ US gal)	36 (7.92/9.51)	
Cooling oil	l (Imp. gal/ US gal)	30 (6.60/7.93)	
Oil filter		Full-flow type	
Pressure differential needed to open bypass valve	bar (psi)	1.5 (21.3)	
Oil pressure warning light comes on below	bar (psi)	0.2...0.5 (2.8...7.1)	
Pressure relief valve opens at	bar (psi)	5.5 (78.3)	
Operating pressure	bar (psi)	3.5...6.0 (49.8...85.4)	
Oil content			
Without filter change	l (Imp. pint/ US quart)	3.50 (6.2/3.69)	
With filter change	l (Imp. pint/ US quart)	3.75 (6.6/3.96)	
min/max	l (Imp. pint/ US quart)	0.5 (0.88/0.53)	
Permissible oil consumption	l/1000 km (miles per Imp. pint/miles per US quart)	1.0 (350/590)	
Oil pump			
Oil pump		2 Duocentric pumps	
Housing depth	mm (in)	12.02...12.05 (0.473...0.474)	
	mm (in)	10.02...10.05 (0.394...0.396)	
Height of rotor	mm (in)	11.95...11.98 (0.470...0.472)	
	mm (in)	9.95...9.98 (0.392...0.393)	
Axial play	mm (in)	0.04...0.1 (0.002...0.004)	
Wear limit	mm (in)	0.25 (0.010)	

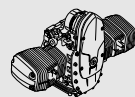

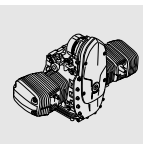

Technical data		R 850 C	R 1200 C
Valves			
Included angle between valves	°	41	
Valve clearances with engine cold (max. 35 °C/95 °F)		0.15 (0.006) 0.30 (0.012)	
Inlet valve	mm (in)		
Exhaust valve	mm (in)		
Valve timing		At zero valve clearance and 3 mm (0.12 in) valve lift	
Inlet opens		17° after TDC	
Inlet closes		15° after BDC	
Exhaust opens		15° before BDC	
Exhaust closes		17° before TDC	
		Tolerance ± 3°	
Valve head dia.			
Inlet	mm (in)	32 (1.26)	34 (1.34)
Exhaust	mm (in)	27 (1.06)	29 (1.14)
Stem dia.			
Inlet	mm (in)	4.966...4.980 (0.1955...0.1960)	
Wear limit	mm (in)	4.946 (0.1947)	
Exhaust	mm (in)	4.956...4.970 (0.1951...0.1956)	
Wear limit	mm (in)	4.936 (0.1943)	
Valve head edge thickness			
Inlet	mm (in)	1.00 ±0.2 (0.04 ±0.008)	
Wear limit	mm (in)	0.5 (0.02)	
Exhaust	mm (in)	1.00 ±0.2 (0.04 ±0.008)	
Wear limit	mm (in)	0.5 (0.02)	
Max. runout of valve head at valve seat			
Inlet, exhaust	mm (in)	0.035 (0.0014)	
Valve seat ring			
Valve seat angle			
Inlet		45°	
Exhaust		45°	
Valve seat width			
Inlet	mm (in)	1.1 ± 0.15 (0.043 ±0.006)	
Wear limit	mm (in)	2.5 (0.10)	
Exhaust	mm (in)	1.4 ± 0.15 (0.055 ±0.006)	
Wear limit	mm (in)	3.0 (0.12)	
Valve seat extl. dia. (dimension for machining seat)			
Inlet	mm (in)	31.4 ±0.1 (1.24 ±0.004)	33.4 ±0.1 (1.32 ±0.004)
Exhaust	mm (in)	26.4 ±0.1 (1.04 ±0.004)	28.4 ±0.1 (1.12 ±0.004)
Seat ring dia. (oversize +0.2 mm/+0.008 in)			
Inlet	mm (in)	34.634...34.650 (1.3635...1.3642)	36.617...36.633 (1.4416...1.4422)
Exhaust	mm (in)	30.134...30.150 (1.1864...1.1870)	32.134...32.150 (1.2651...1.2658)
Seat dia. in cyl. head (oversize +0.2 mm/+0.008 in)			
Inlet	mm (in)	34.500...34.525 (1.3583...1.3592)	36.500...36.525 (1.4370...1.4380)
Exhaust	mm (in)	30.000...30.025 (1.1811...1.1821)	32.000...32.025 (1.2599...1.2608)

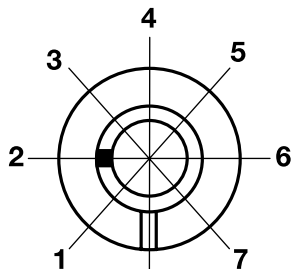
Technical data			R 850 C	R 1200 C
Valve guide				
Valve guide	Extl. dia.	mm (in)	12.533...12.544 (0.4934...0.4939)	
Bore in cylinder head		mm (in)	12.500...12.518 (0.4921...0.4928)	
Overlap		mm (in)	0.015...0.044 (0.0006...0.0017)	
Repair stages				
Replacement valve guide	Extl. dia.	mm (in)	12.550...12.561 (0.4941...0.4945)	
Oversize valve guide	Extl. dia.	mm (in)	12.733...12.744 (0.5013...0.5017)	
Valve guide	Intl. dia.	mm (in)	5.0...5.012 (0.1969...0.1973)	
Radial clearance				
	Inlet	mm (in)	0.020...0.046 (0.0008...0.0018)	
	Wear limit	mm (in)	0.15 (0.006)	
	Exhaust	mm (in)	0.030...0.056 (0.0012...0.0022)	
	Wear limit	mm (in)	0.17 (0.007)	
Valve spring				
Spring length, off-load		mm (in)	41.1 (1.62)	
Wear limit		mm (in)	39.0 (1.54)	
Rocker				
Bore dia.		mm (in)	16.016...16.027 (0.6306...0.6310)	
Rocker shaft dia.		mm (in)	15.973...15.984 (0.6289...0.6293)	
Radial clearance		mm (in)	0.032...0.054 (0.0016...0.0021)	
	Wear limit	mm (in)	0.1 (0.004)	
Axial play				
	min.	mm (in)	0.05 (0.002)	
	max.	mm (in)	0.40 (0.016)	
Camshaft				
Opening angle, inlet/exhaust cams			256°/256°	
Cam spread, inlet/exhaust			106°/109°	
Marking			Marking in position 2	
				
Inlet valve lift		mm (in)	8.23 (valve clearance = 0)	
Exhaust valve lift		mm (in)	8.23 (valve clearance = 0)	
Camshaft bearing bore dia.		mm (in)	21.02...21.04 (0.8276...0.8284)	
Camshaft dia.		mm (in)	20.97...21.00 (0.826...0.827)	
Radial clearance		mm (in)	0.02...0.07 (0.0008...0.0028)	
	Wear limit	mm (in)	0.15 (0.006)	
Width of guide bearing		mm (in)	15.92...15.95 (0.6268...0.6280)	
Width of camshaft bearing		mm (in)	16.0...16.05 (0.630...0.632)	
Axial play		mm (in)	0.08...0.13 (0.0031...0.0051)	
	Wear limit	mm (in)	0.25 (0.010)	

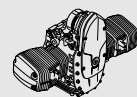

Technical data		R 850 C	R 1200 C
Bucket-type tappet			
Extl. dia.	mm (in)	23.947...23.960 (0.9428...0.9433)	
Bore dia. in cylinder head	mm (in)	24.000...24.021 (0.9449...0.9457)	
Radial clearance	mm (in)	0.040...0.074 (0.0016...0.0029)	
Wear limit	mm (in)	0.18 (0.007)	
Auxiliary shaft			
Bore dia. in crankcase front/back	mm (in)	25.020...25.041 (0.9851...0.9859)	
Auxiliary shaft dia. front/back	mm (in)	24.959...24.980 (0.9827...0.9835)	
Radial clearance	mm (in)	0.040...0.082 (0.0016...0.0032)	
Wear limit	mm (in)	0.17 (0.007)	
Crankshaft			
Marking of main bearing and crankpin on front crank web			
no paint mark		Grinding stage 0	
paint mark		Grinding stage 1 (-0.25 mm/-0.010 in)	
Grinding stage 0 (grinding stage 1 = -0.25 mm/-0.010 in)			
Guide bearing bore dia.	mm (in)	64.949...64.969 (2.5571...2.5579)	
Guide bearing dia.	mm (in)	Green: 59.964...60.003 (2.3609...2.3624) Yellow: 59.974...60.013 (2.3612...2.3628)	
Main bearing journal dia.	mm (in)	Green: 59.939...59.948 (2.3598...2.3602) Yellow: 59.949...59.958 (2.3602...2.3606)	
Radial clearance	mm (in)	0.016...0.064 (0.0006...0.0025)	
Wear limit	mm (in)	0.1 (0.004)	
Main bearing bore dia.	mm (in)	60.000...60.019 (2.3622...2.3629)	
Main bearing dia.	mm (in)	Green: 54.998...55.039 (2.1653...2.1669) Yellow: 55.008...55.049 (2.1657...2.1673)	
Main bearing journal dia.	mm (in)	Green: 54.971...54.980 (2.1643...2.1646) Yellow: 54.981...54.990 (2.1646...2.1650)	
Radial clearance	mm (in)	0.018...0.068 (0.0007...0.0028)	
Wear limit	mm (in)	0.13 (0.0051)	
Width of guide bearing	mm (in)	24.890...24.940 (0.9799...0.9819)	
Bearing width of main bearing journal	mm (in)	25.020...25.053 (0.9851...0.9864)	
Axial play	mm (in)	0.080...0.163 (0.0031...0.0064)	
Wear limit	mm (in)	0.2 (0.008)	
Grinding stage 0 (grinding stage 1 = -0.25 mm/-0.010 in)			
Crankpin dia.	mm (in)	47.975...47.991 (1.8888...1.8894)	
Bearing width of crankpin	mm (in)	22.065...22.195 (0.8687...0.8738)	

Technical data		R 850 C	R 1200 C
Connecting rod			
Bore dia. for big end bearing	mm (in)	51.000...51.013 (2.0079...2.0084)	
Big end bearing dia.	mm (in)	48.016...48.050 (1.8904...1.8918)	
Radial clearance	mm (in)	0.025...0.075 (0.0010...0.0030)	
Wear limit	mm (in)	0.13 (0.0051)	
Width of big end bearing eye	mm (in)	21.883...21.935 (0.8616...0.8636)	
Conrod end float	mm (in)	0.130...0.312 (0.0051...0.0123)	
Wear limit	mm (in)	0.5 (0.02)	
Small end bearing bore dia.	mm (in)	22.015...22.025 (0.8667...0.8671)	
Radial clearance	mm (in)	0.015...0.030 (0.0006...0.0012)	
Wear limit	mm (in)	0.06 (0.002)	
Distance between centers	mm (in)	125 (4.92)	
Max. deviation from parallel of conrod bores at 150 mm (5.90 in) spacing	mm (in)	0.07 (0.003)	
Cylinders			
Bore		(20 mm/0.79 in from top edge)	
A	mm (in)	87.492...87.500 (3.4446...3.4449)	100.992...101.000 (3.9761...3.9764)
Wear limit	mm (in)	87.550 (3.4468)	101.050 (3.9784)
B	mm (in)	87.500...87.508 (3.4449...3.4452)	101.000...101.008 (3.9764...3.9768)
Wear limit	mm (in)	87.558 (3.4471)	101.058 (3.9787)
Total wear clearance of piston and cylinder	mm (in)	0.12 (0.005)	
Permitted out-of-roundness of cylinder bore			
20 mm (0.79 in) from the top edge	mm (in)	0.03 (0.0012)	
100 mm (3.94 in) from the top edge	mm (in)	0.04 (0.0016)	
Pistons			
Piston dia.		(Measuring plane A – see Checking pistons and cylinders)	
A	mm (in)	87.465...87.477 (3.4435...3.4440)	100.971...100.983 (3.9753...3.9758)
Wear limit	mm (in)	87.390 (3.4405)	100.895 (3.9723)
B	mm (in)	87.477...87.485 (3.4440...3.4443)	100.983...100.995 (3.9753...3.9763)
Wear limit	mm (in)	87.400 (3.4409)	100.905 (3.9727)
AB	mm (in)	87.473...87.481 (3.4438...3.4441)	100.979...100.987 (3.9756...3.9759)
Wear limit	mm (in)	87.395 (3.4407)	100.900 (3.9725)
Installed clearance	mm (in)	0.011...0.035 (0.0004...0.0013)	0.005...0.029 (0.0002...0.0011)
Total wear clearance of piston and cylinder	mm (in)	0.12 (0.005)	
Piston pin bore dia.	mm (in)	22.005...22.011 (0.8664...0.8666)	
Weight classes		+ and –	
Weight difference in one class	grammes (oz)	10 (0.353) (complete with pins and rings)	
Direction of installation		Arrow on piston crown pointing to exhaust side Production locating point towards exhaust side (see Installing piston)	

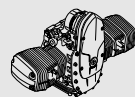

Technical data		R 850 C	R 1200 C
Piston rings			
1st groove	Piston ring asymmetrical, convex oval		
	Height	mm (in)	1.170...1.190 (0.0461...0.0469)
	Wear limit	mm (in)	1.1 (0.043)
Gap clearance		mm (in)	0.1...0.3 (0.004...0.012)
	Wear limit	mm (in)	0.8 (0.031)
Side clearance		mm (in)	0.030...0.070 (0.0012...0.0027)
	Wear limit	mm (in)	0.15 (0.0006)
2nd groove	Micro-taper compression ring		
	Height	mm (in)	1.170...1.190 (0.0461...0.0469)
	Wear limit	mm (in)	1.1 (0.043)
Gap clearance		mm (in)	0.2...0.4 (0.008...0.016)
	Wear limit	mm (in)	1.0 (0.040)
Side clearance		mm (in)	0.030...0.070 (0.0012...0.0027)
	Wear limit	mm (in)	0.15 (0.0006)
3rd groove	Equal-chamfer ring + tubular spring		
	Height	mm (in)	1.970...1.990 (0.0776...0.0783)
	Wear limit	mm (in)	1.9 (0.075)
Gap clearance		mm (in)	0.30...0.55 (0.012...0.022)
	Wear limit	mm (in)	1.20 (0.047)
Side clearance		mm (in)	0.020...0.060 (0.0008...0.0024)
	Wear limit	mm (in)	0.15 (0.0006)
Installed direction of piston rings			"Top" marking uppermost
Piston pin			
Piston pin dia.		mm (in)	21.995...22.000 (0.8660...0.8662)
	Wear limit	mm (in)	21.960 (0.8646)
Bore dia. in piston		mm (in)	22.005...22.011 (0.8664...0.8666)
Radial clearance in piston		mm (in)	0.005...0.016 (0.0002...0.0006)
	Wear limit	mm (in)	0.070 (0.0027)

Sectioned drawing of engine

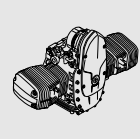
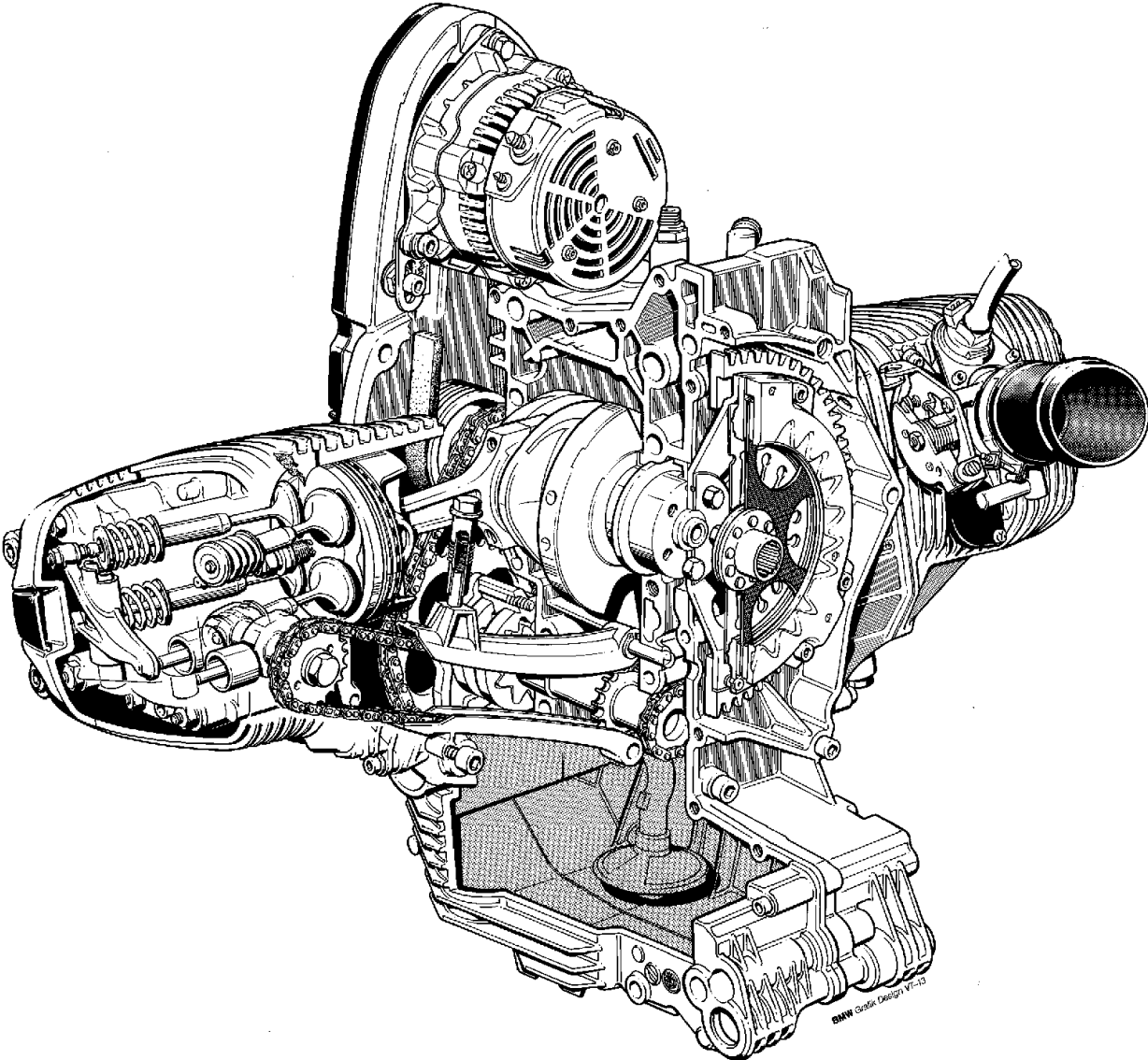

Lubricating oil circuit

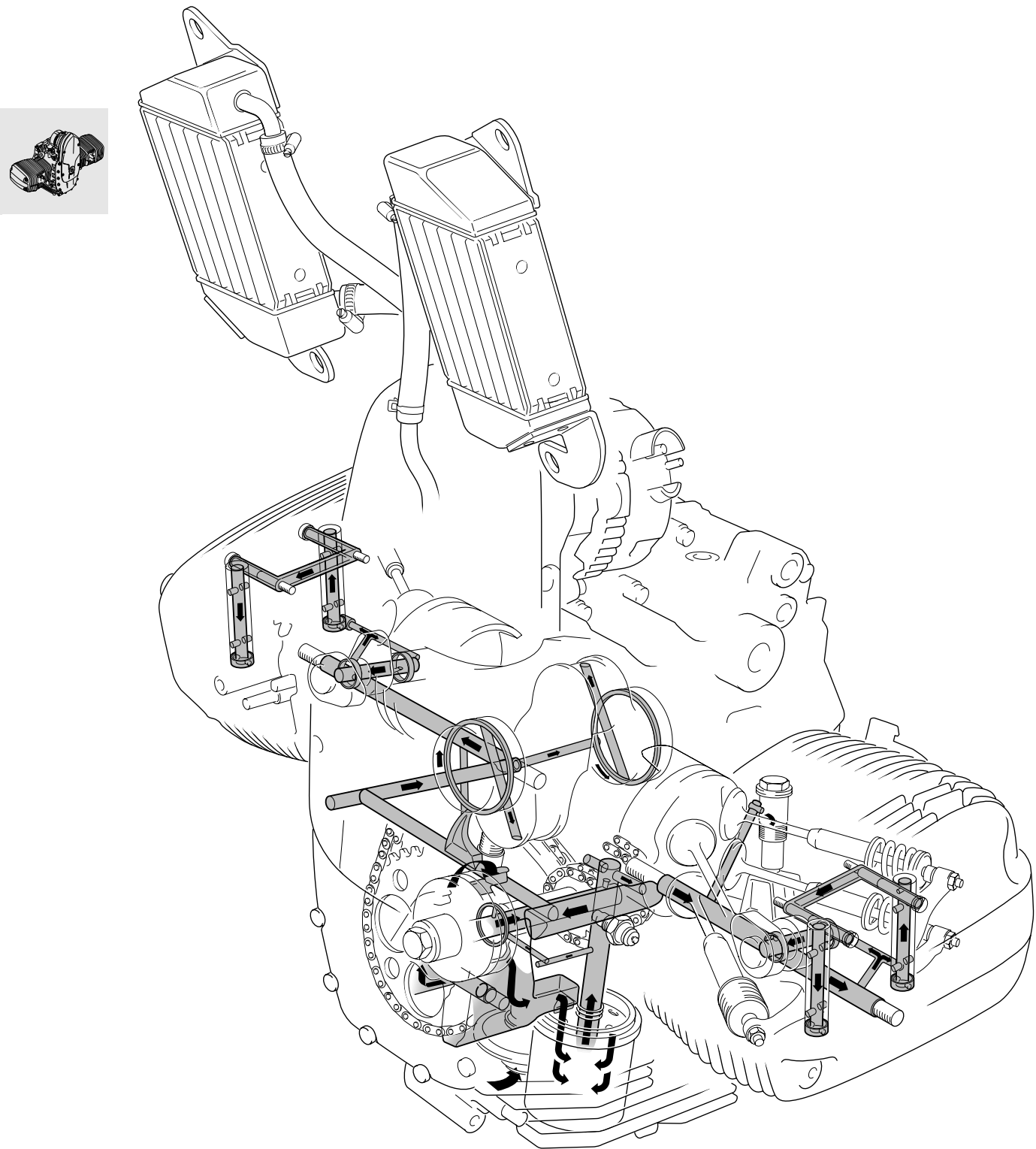

Coolant circuit

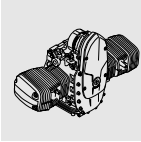
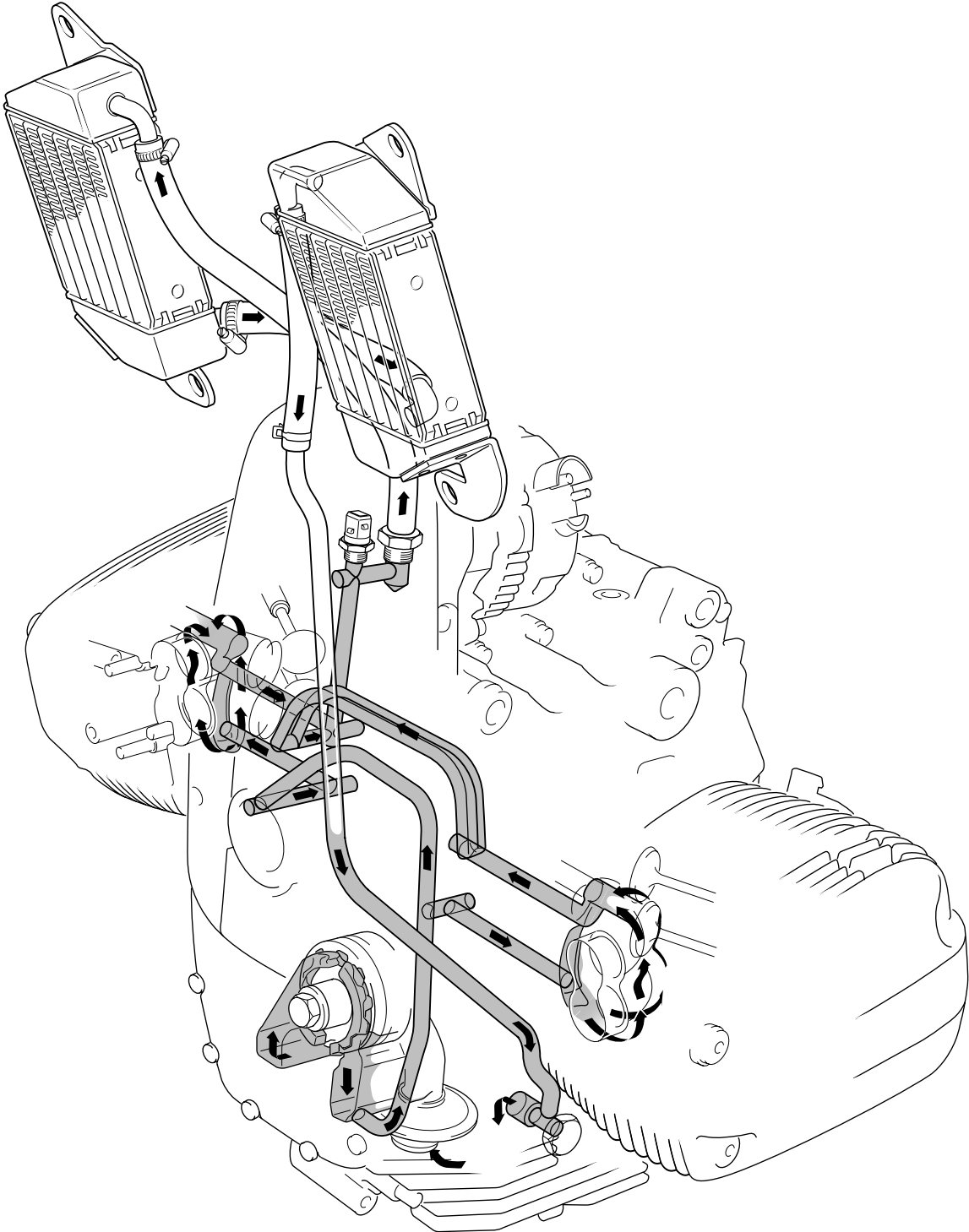

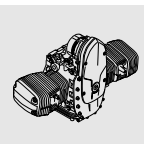

Removing engine



Note:

Auxiliary shaft, timing chains, chain tensioner/guide rails and crankshaft can only be dismantled after the engine has been removed. All other components can be dismantled while the engine is still installed.

- Drain engine oil.
- Drain the brake system completely.
- Drain the clutch operating system completely.

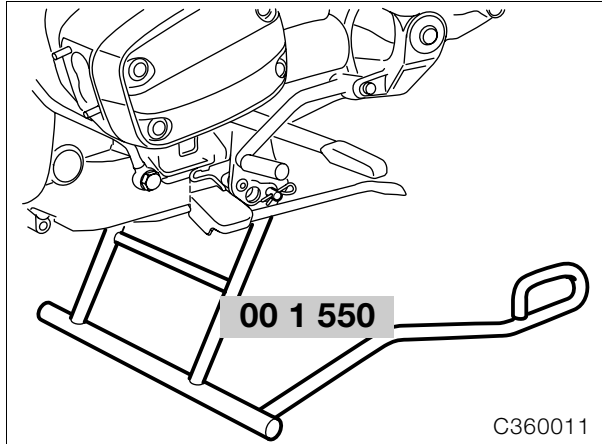

- Attach auxiliary stand, **BMW No. 00 1 550**, to the motorcycle.

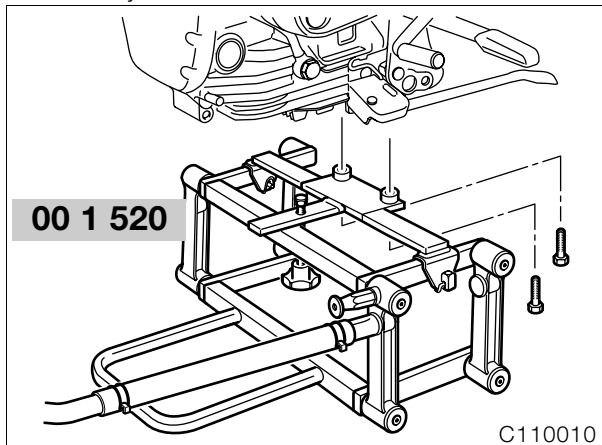

- Attach stand, **BMW No. 00 1 520**, to motorcycle.
- Remove seat.
- Remove side trim.
- Remove fuel tank.
- Remove the battery.



Caution:

Disconnect negative terminal first, then positive terminal.

- Remove rear wheel.
- Detach the rear brake caliper.
- Detach the ABS sensor.
- Detach the speedometer sensor.
- Remove exhaust manifold.
- Remove silencer (muffler).
- Separate oxygen sensor plug.
- Remove line protection from swinging arm.
- Tie the swinging arm up to the rear frame with a strap.
- Remove suspension strut.



Note:

Press the upper suspension strut to the rear.

- Remove rear wheel drive unit.
- Detach brake hose holder at rear frame.

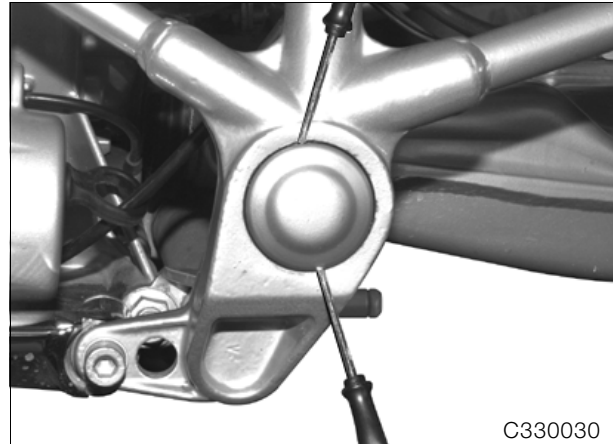

- Press off the left swinging arm bearing cap.



Caution:

When installing, make sure the O-ring is in good condition.

Install with the drain hole pointing down.

- Loosen the left swinging arm bearing.
- Loosen the screws at the right swinging arm bearing.

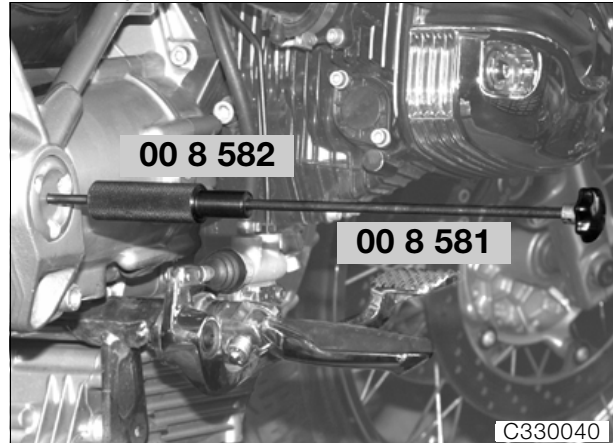

- Use pull rod, **BMW No. 00 8 581**, and impact weight, **BMW No. 00 8 582**, to pull out the swinging arm bearing.
- Remove the left swinging arm bearing.

- Remove rear swinging fork.

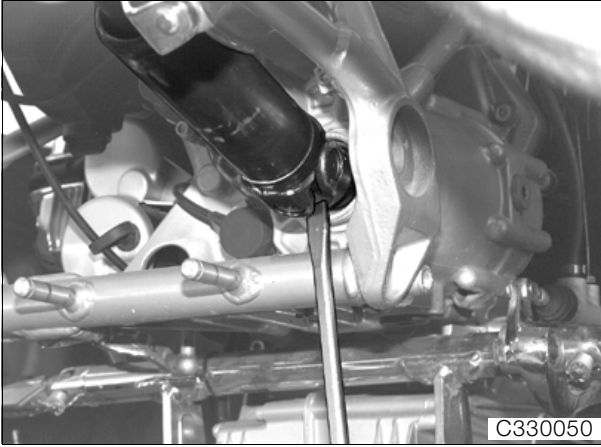

- Press off drive shaft.
- Remove the air intake stub pipe.
- Remove brake fluid reservoir from holder.
- Remove the holder.
- Take off the right plug retaining plate.
- Pull the air temperature plug off the air cleaner cover.
- Detach the gear lever at the pivot.
- Remove the gear lever.
- Separate the plug for the throttle angle potentiometer and the throttle positioner at the left plug retaining plate.
- Disconnect both fuse boxes at the plug retaining plate.
- Separate the side (prop) stand safety switch plug.
- Separate the neutral indicator plug.
- Detach the left plug retaining plate.
- Remove the injector nozzles.
- Pull the plug off the injector line.
- Separate the plug for the rear brake light switch and detach the wire.
- Detach the vent hose at the air cleaner housing.
- Disconnect the throttle cable at the twistgrip.
- Remove rear section of frame.
- Remove the auxiliary stand.
- Remove the footrest holder.
- Remove the starter motor cover.
- Detach cable from starter motor.
- Remove the starter motor.
- Separate the clutch line where it passes through the frame.
- Remove the clutch slave cylinder with line.
- Pull out the thrust rod.

- Detach the gearbox.

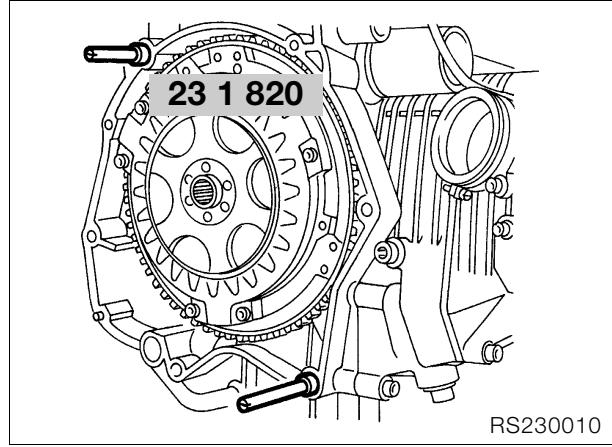

- When removing the gearbox, pull it out on guide pins, **BMW No. 23 1 820**.
- Remove the Motronic control unit.
- Disconnect the wires in the central electrical equipment box.
 - Instruments
 - Right combined switch
 - Left combined switch
 - Front brake light switch
 - Clutch switch
 - Front ABS sensor
- Undo the cable straps at the wiring.
- Detach the central electrical equipment box.
- Remove the brake lines from the pressure modulator to the front junction box.

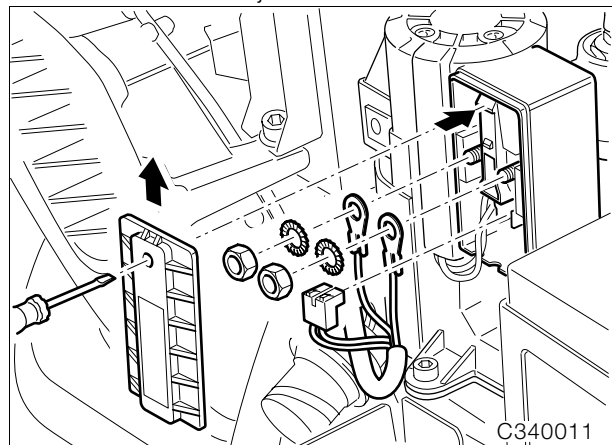

- Detach the lines at the pressure modulator.
- Remove the ABS unit.



Caution:

Comply exactly with the instructions in the Repair Manual.

→Group 34

- Remove battery carrier.
- Remove the horn.
- Remove the ignition coil.
- Pull off the plug cap with special puller, **BMW No. 12 3 520**, and remove the ignition lead.
- Open the headlight housing.
- Detach the headlight cable.
- Detach the flashing turn indicator wires.
- Detach the oil pressure switch wire.
- Detach the alternator cables.

- Detach the central earth (ground) wire at the engine block.
- Remove the left air intake pipe at the cylinder head.
- Heat the ball joint mount at the leading link to max. 120 °C (248 °F) and detach it.



Caution:

Do not scratch the surface of the leading link.

- Detach the line for the front brake caliper at the junction block/frame.
- Remove the caps from the threaded connections on the fixed tubes.
- Separate the fixed tube from the fork bridge at the threaded connections.
- Remove the telescopic fork.
- Remove the cover plate over the upper suspension strut mount on the frame.
- Remove suspension strut.
- Remove the leading link caps.
- Remove the left screw cap.
- Remove the circlip at the right and the safety cap.
- Take out the screw at the right and pull the shaft out to the left.
- Remove the leading link.
- Detach the hose for the oil cooler at the engine.
- Remove frame.
- Install by following the above work instructions in the reverse order.

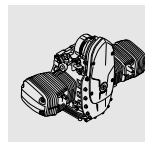

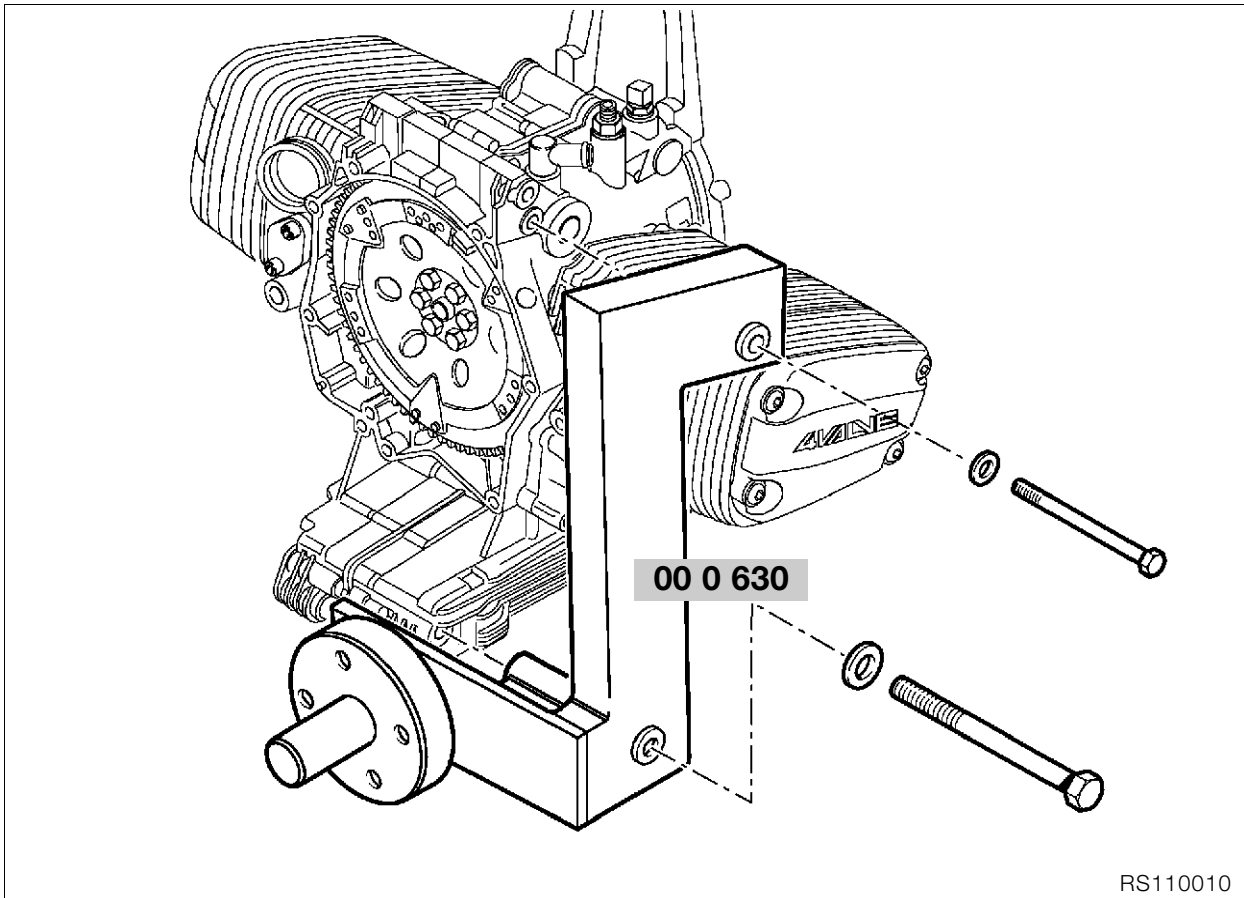

Dismantling engine

- Attach engine mount, **BMW No. 11 0 630**, to the engine block.
- Transfer engine to assembly frame.

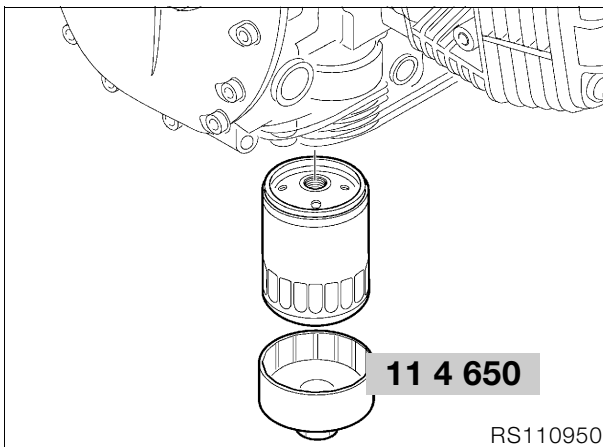

- Drain engine oil.
- Remove the oil filter, using oil filter wrench, **BMW No. 11 4 650**.

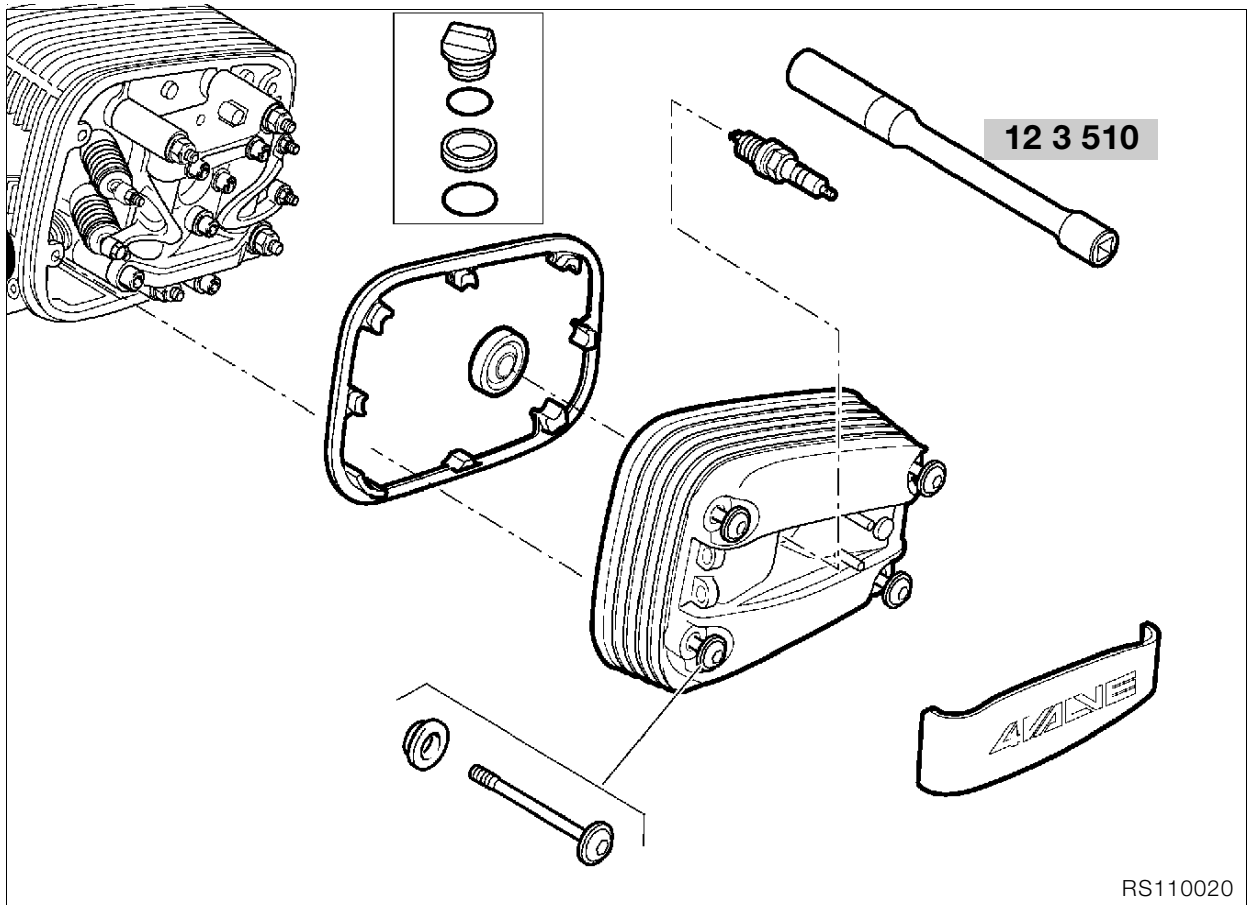

Removing cylinder head cover

- Unscrew and remove spark plug with the spark plug wrench, **BMW No. 12 3 510**.
- Remove cylinder head cover.



Caution:
Trap escaping oil.

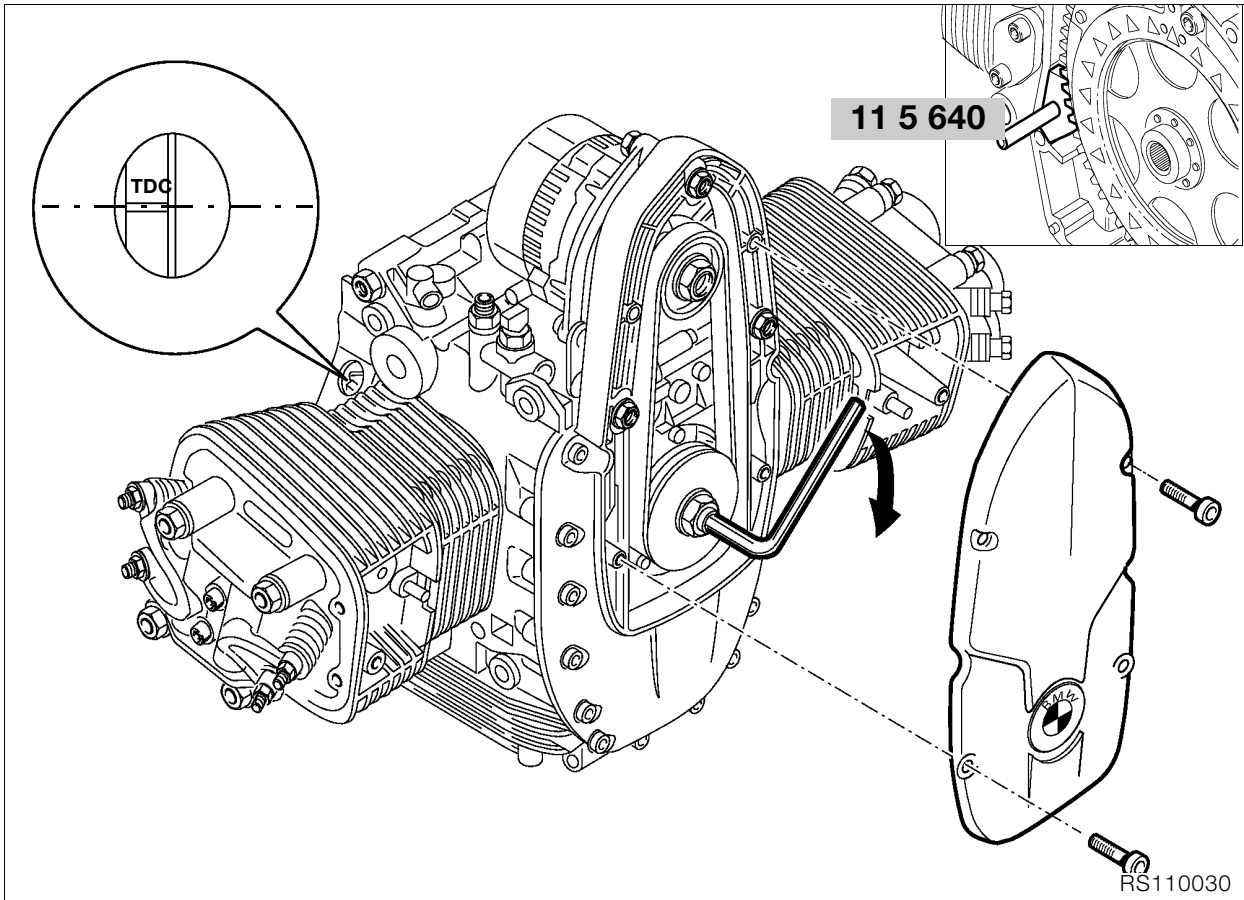

Locking the engine in the TDC position

- Remove front cover.
- Turn the belt pulley to move the piston to TDC on the ignition stroke.

Top dead centre on ignition stroke:

1. TDC mark is visible, and
 2. The inlet and exhaust valves in the cylinder in question are closed.
- Prevent the clutch housing from moving with locking device, **BMW No. 11 5 640**.

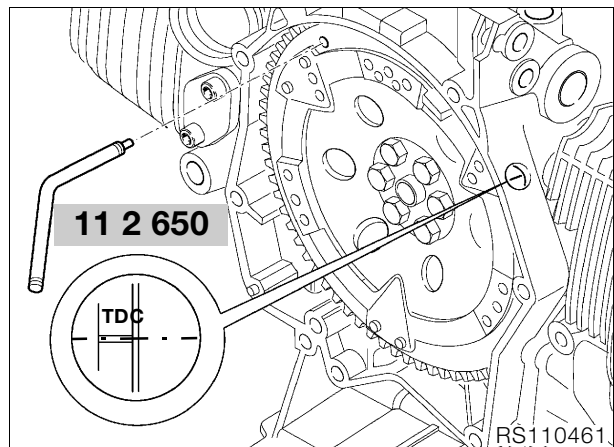

Note:

The engine can be correctly positioned at TDC with locating pin, **BMW No. 11 2 650**, through the hole in the clutch housing and the engine block.

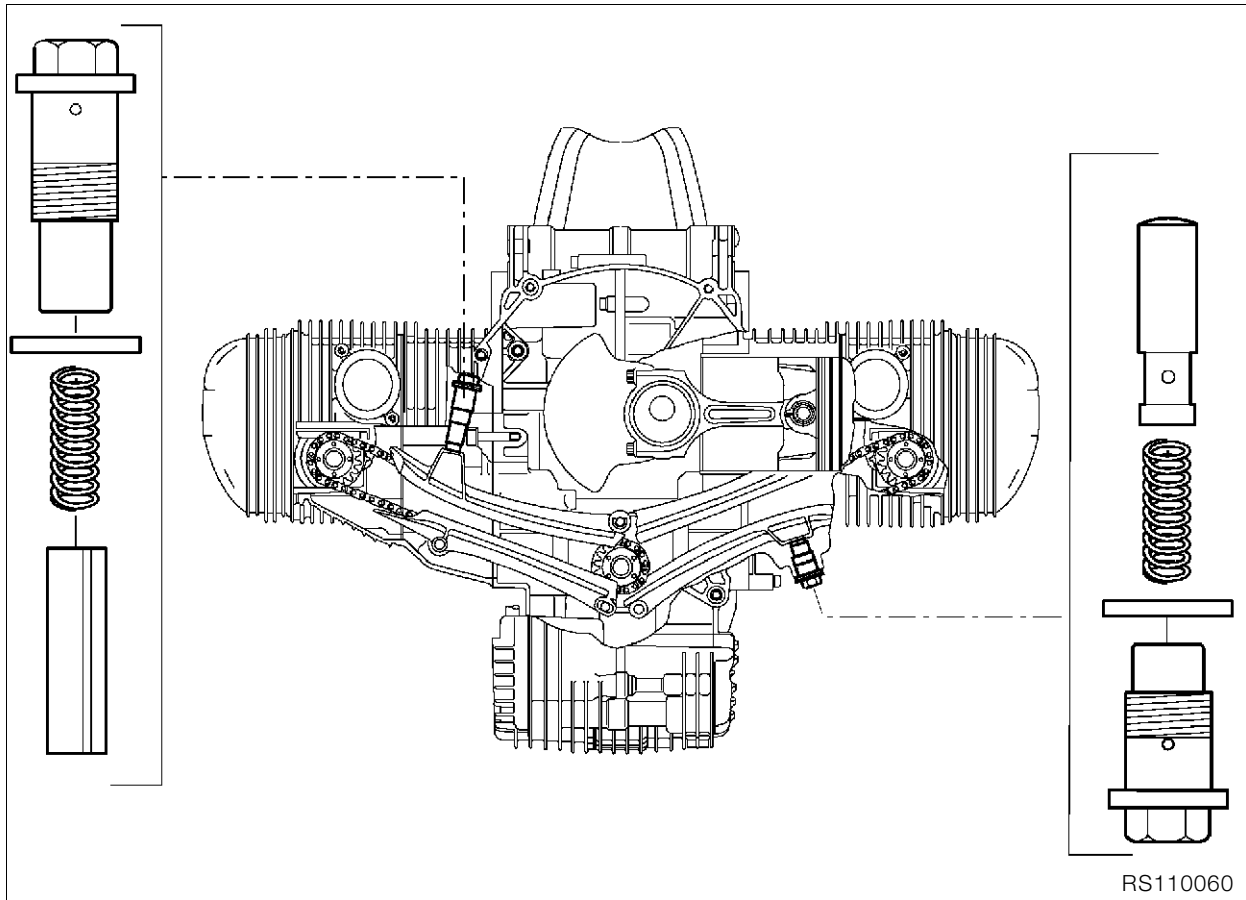

Removing and installing chain tensioner

Caution:

Do not accidentally confuse the chain tensioner pistons. When installing, fit a new gasket.

Assembly specification for timing chain tensioner:

Removal:

- Remove timing chain tensioner, then remove camshaft sprocket from camshaft.

Installing:

- First install camshaft sprocket, then timing chain tensioner.

Caution:

Failure to observe this sequence can cause the chain tensioner piston to fall into the left side of the timing chain cavity.

Tightening torque:

Chain tensioner 32 Nm

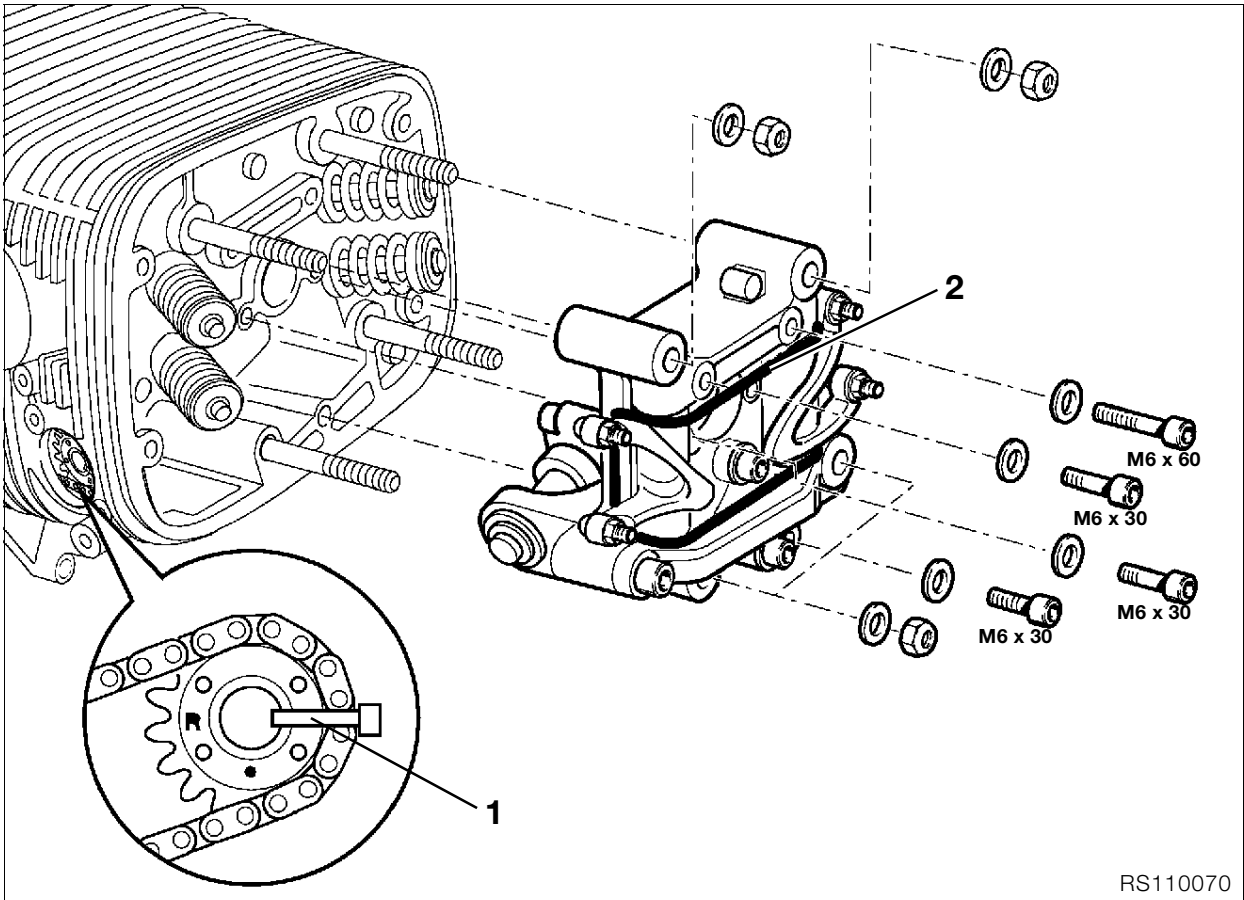

RS110070

Removing valve gear holder

- Remove valve gear holder.
- Secure rockers with a rubber band (2).



Note:

If no work is carried out on the valve gear holder, remove it together with the cylinder head.

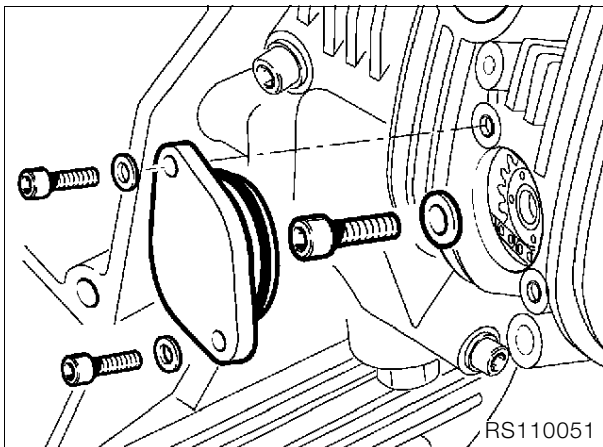

RS110051

- Remove camshaft sprocket cover.
- Unscrew/press off camshaft sprocket.



Note:

If the camshaft sprocket (1) is not removed after loosening, it must be held firmly and prevented from falling into the engine block (e.g. with a cable strap).

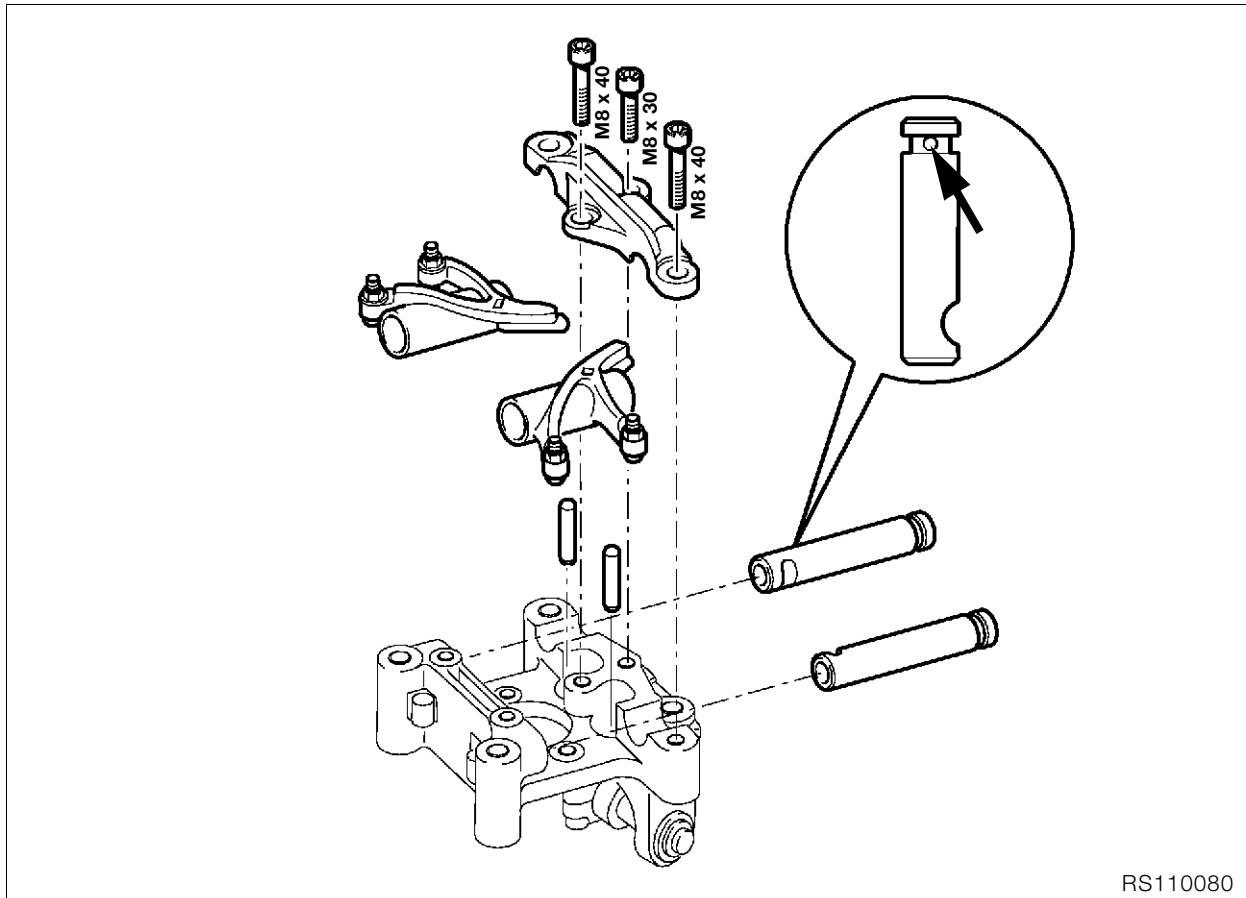

RS110080

Dismantling/reassembling valve gear holder

- Remove bearing cap.
- Insert a suitable drift into the bore (arrow) of the rocker shaft, and pull the shaft out of the mount by twisting it in both directions.
- Remove pushrods.



Caution:

Do not accidentally confuse rocker shafts and pushrods.

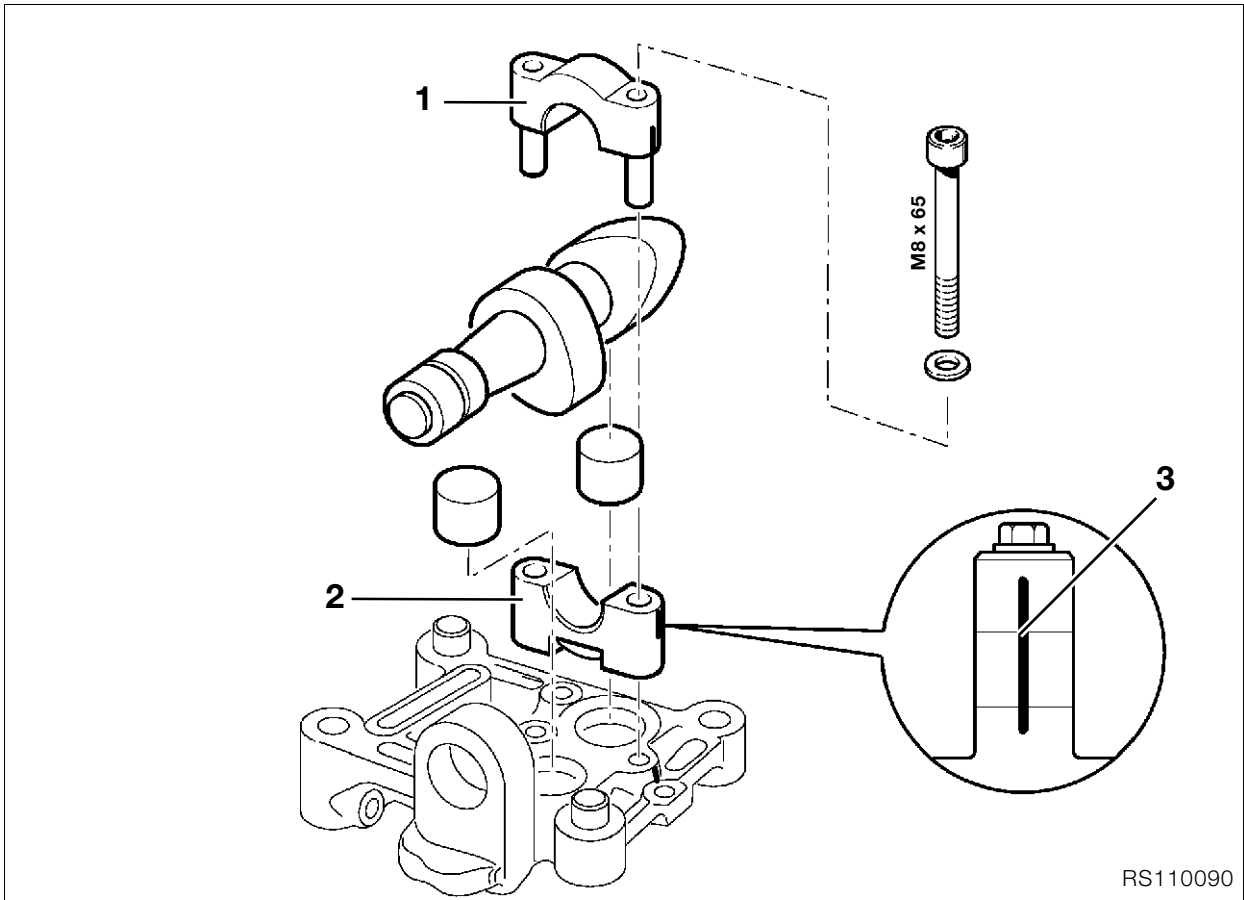

RS110090

- Remove camshaft bearing cap (1).
- Remove camshaft and bearings (2).
- Remove bucket-type tappets.



Caution:

Do not accidentally confuse the bucket-type tappets.

- Reassemble in the reverse order of work.



Caution:

Note direction of installation (3) for camshaft bearing cap. The cutout on the rocker shafts must be aligned with the retaining holes.



Note:

Locate pushrods in ball cups on rockers and hold the rockers together with a rubber band to secure the pushrods in position.

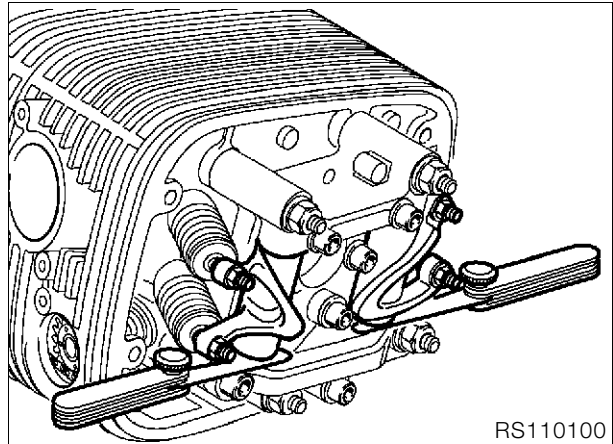

RS110100

- Reposition the bearings until minimum endplay is obtained.

End float of rocker:

min..... 0.05 mm (0.002 in)
 max. 0.40 mm (0.016 in)



Tightening torque:

M 8 screw, rocker shaft bearing cap 15 Nm
 M 8 screw for camshaft bearing cap 15 Nm

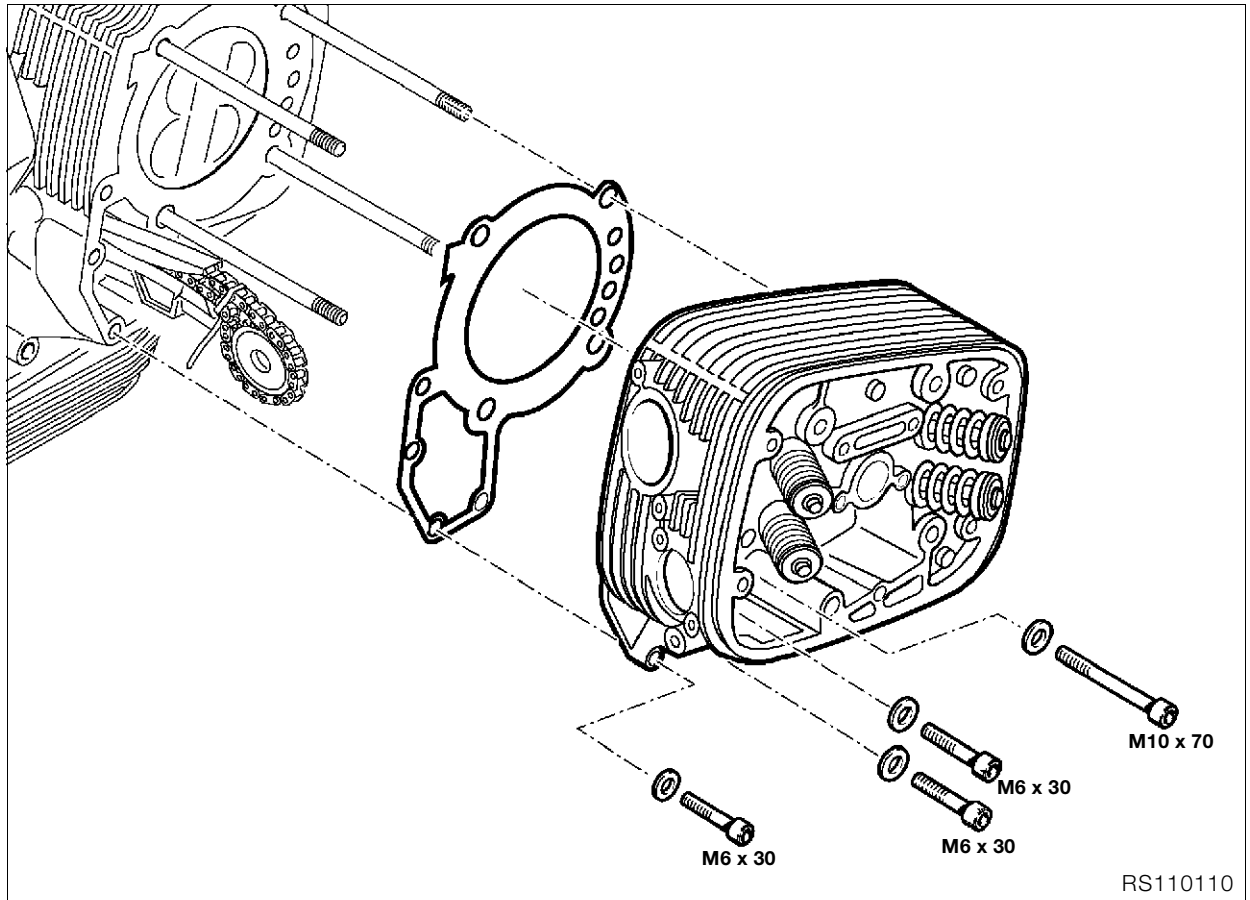

Removing cylinder head

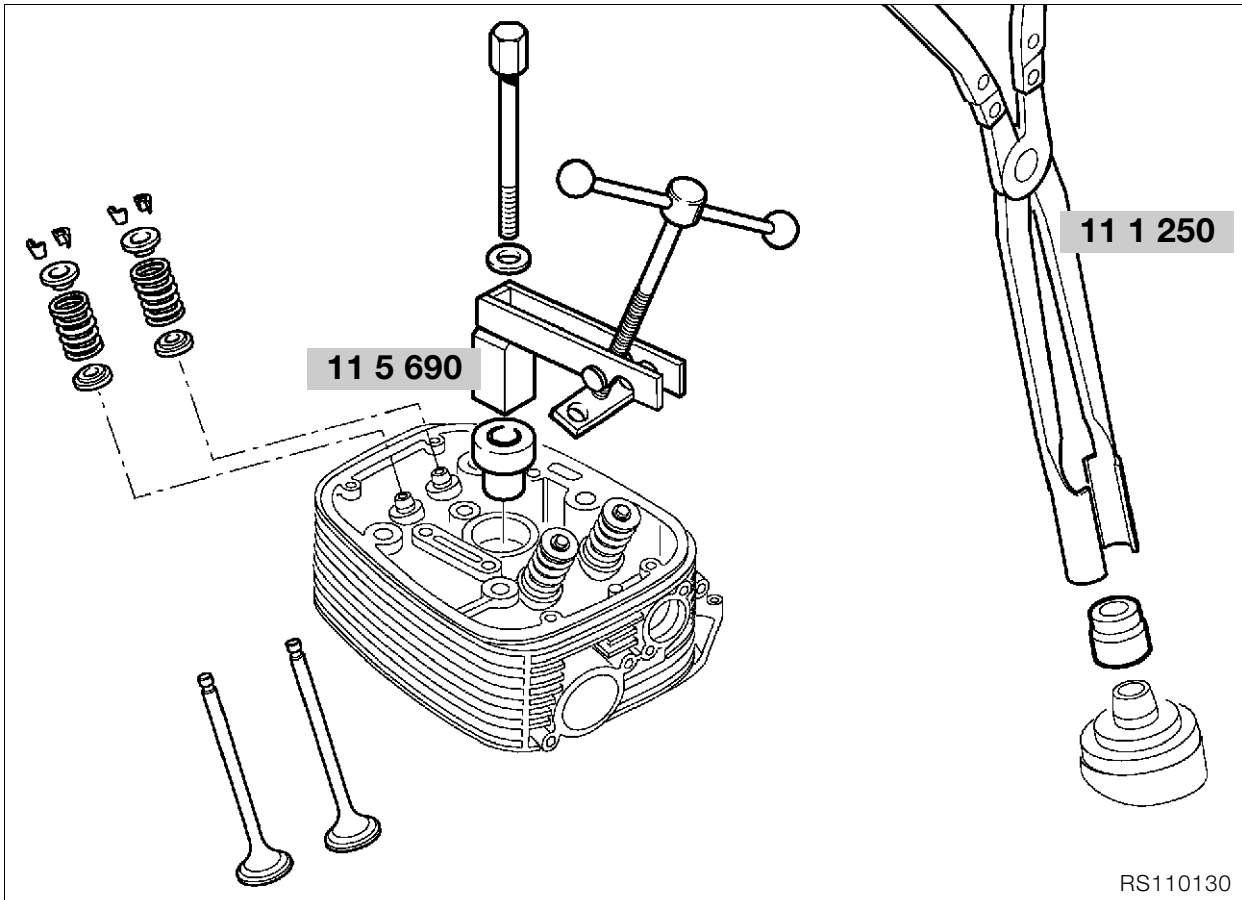

RS110130

Dismantling, checking, repairing and re-assembling cylinder head

Removing and installing valves



Caution:

Do not scratch sealing face on cylinder head. Place the head on a clean, scratch-free surface.

- Attach valve spring tensioner, **BMW No. 11 5 690**, to cylinder head.
- Clamp the valve springs.
- Separate valve collet from spring plate by striking the valve head gently.
- Remove valve collet sections.
- Relieve tension on valve springs.
- Remove top/bottom spring plates, valve springs and valves.

Removing valve stem seals

- Pull off valve stem seal with pliers, **BMW No. 11 1 250**.



Note:

If a valve is removed, the valve stem seal must be renewed.

Checking valves for wear

- Clean combustion residue from valves.
 - Check valve dimensions.
- ⇒See Technical data

Remachining valve seat

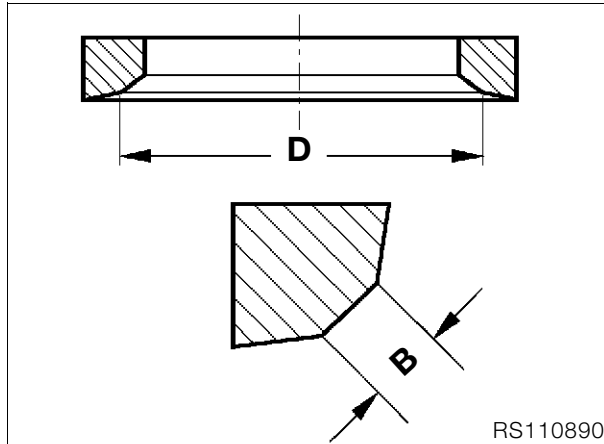

Caution:

Width (B) and diameter (D) must always be maintained when remachining the valve seat.

⇒See Technical data

Checking and repairing cylinder head

- Remove combustion residues from combustion chamber.
- Check sealing face for damage/distortion, and skim flat if necessary.

Skimming sealing

face: max. 0.2 mm (0.008 in) metal removal

Checking valve guide for wear

- Check valve guide bore.
- ⇒See Technical data

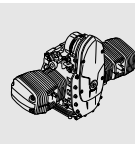

Replacing valve guides

- Heat cylinder head slowly and uniformly to 200 °C (392 °F) in a suitable oven.



Caution:

Wear protective gloves when handling heated parts.

- Drive out valve guides with 5 mm (0.20 in) dia. extractor pin, **BMW No. 11 5 674**, from the combustion chamber side.
- Allow cylinder head to cool down to room temperature (app. 20 °C/68 °F).
- Examine valve guide bore for:
 - wear,
 - widening taper and
 - correct dimensions in H7 tolerance range (12.500...12.518 mm/0.4921...0.4928 in).



Note:

Valve guides are installed in the cylinder head with an interference fit of 0.015...0.044 mm (0.0006...0.0017 in).

If valve guide bore is undamaged and dimensions are within correct 12.5 H7 tolerance range:

- Use original 12.5 U6 (12.533...12.544 mm/0.4934...0.4939 in) valve guide.
- Measure valve guides with micrometer.

If valve guide bore is undamaged but slightly larger than the 12.5 H7 tolerance range:

- Use replacement valve guide 12.550...12.561 mm (0.4941...0.4945 in).

If valve guide bore is damaged or not to correct dimensions in 12.5 H7 tolerance range:

- Use an oversize 12.7U6 (12.733...12.744 mm/0.5013...0.5017 in) valve guide.

Repair method 1 – ream out the bore (if bore is damaged or not to correct dimensions)

- Determine actual diameter of valve guide using micrometer.
- Open out bore with Ø12.7 H7 mm (12.700...12.718 mm/0.5000...0.5007 in) reamer.

Repair method 2 – lathe-turn the valve guide (bore must not be damaged)

- Determine actual diameter of bore with internal measuring tool.
- Calculate the nominal diameter of the valve guide:

Nominal diameter of valve guide = bore dia. + interference-fit value (0.015...0.044 mm/0.0006...0.0017 in).

- Use an oversize 12.7 U6 (12.733...12.744 mm/0.5013...0.5017 in) valve guide.
- Turn down oversize valve guide to nominal dimension.

- Slowly heat cylinder head to 200 °C (392 °F) in a suitable oven.
- Immerse valve guide in liquid grinding paste.
- Freeze valve guide with dry ice.



Caution:

Immediately before pressing in, the temperature must be –40 °C (–40 °F).

- Place heated cylinder head flat on workbench or a similar surface.
- After cooling, place the valve guide on driving-in pin, driving-in pin, Ø 5mm (0.20 in), **BMW No. 11 5 673**.
- Insert valve guides into cylinder head with no delay.
- Allow cylinder head to cool down to room temperature, app. 20 °C (68 °F).
- Inspect bore in valve guide.



Note:

Valve guides for repair purposes are produced with an internal diameter of 5.01 mm (0.1972 in) H7. In most cases, the bore is within the 5.00 mm (0.1969 in) H7 tolerance range after pressing in. If the bore is too narrow, ream it out to size.

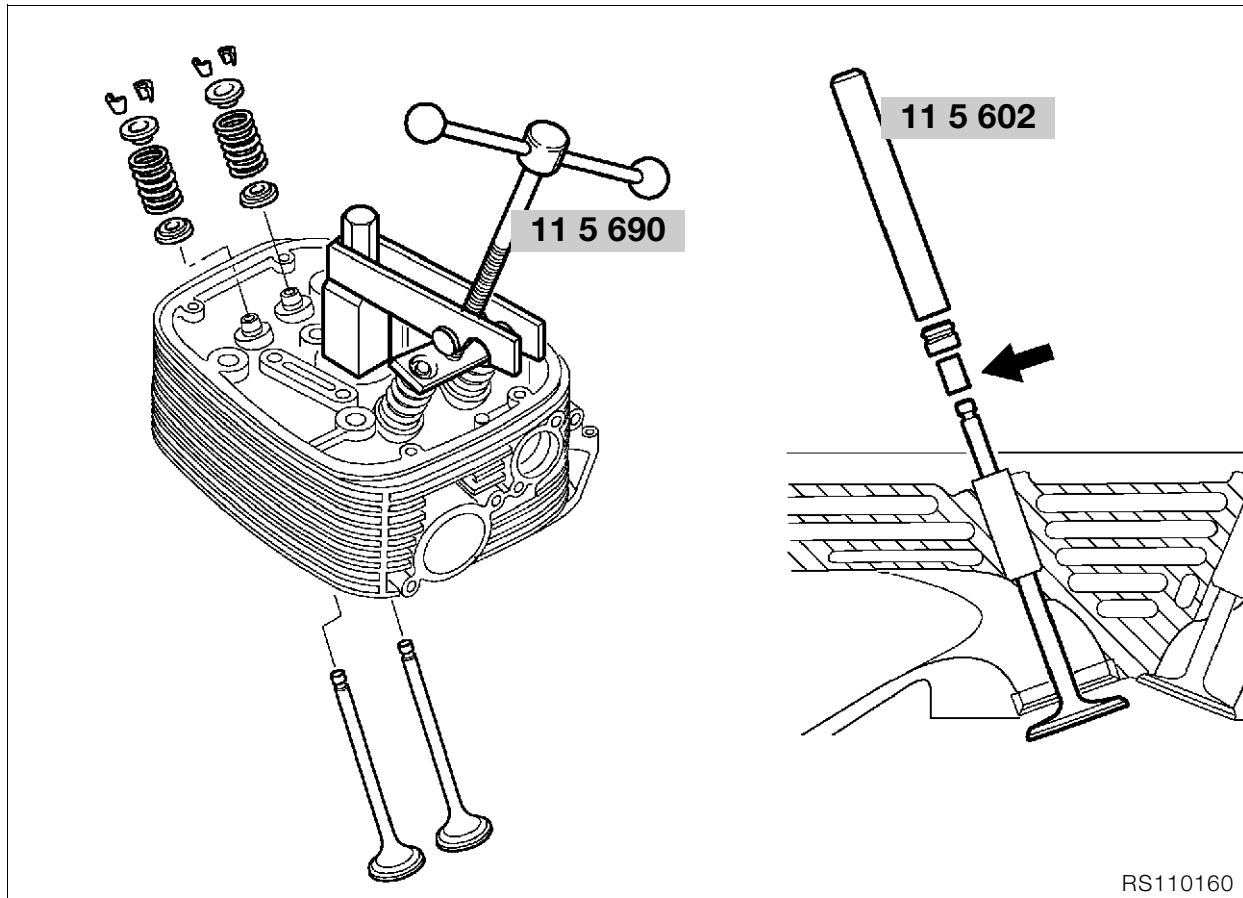

RS110160

Installing valve and valve stem seal



Note:

If a valve was removed, the valve stem seal must be renewed.

- Oil the stem when installing the valve.
- Shrink a short length of tube (arrow) on to the end of the valve stem.
- Install the valve stem seal with a 5 mm (0.20 in) dia. drift, **BMW No. 11 5 602**.



Caution:

Remove the shrunk-on tube.

- Fit lower spring plate, valve spring and upper spring plate.
- Compress the valve springs with the valve spring clamp, **BMW No. 11 5 690**.



Note:

Insert the taper valve collets using grease (to simplify assembly).



Caution:

Ensure that valve collets are correctly seated in the valve stem grooves.

- Relieve tension on valve springs.
- Check valves for leakage (blow-by).

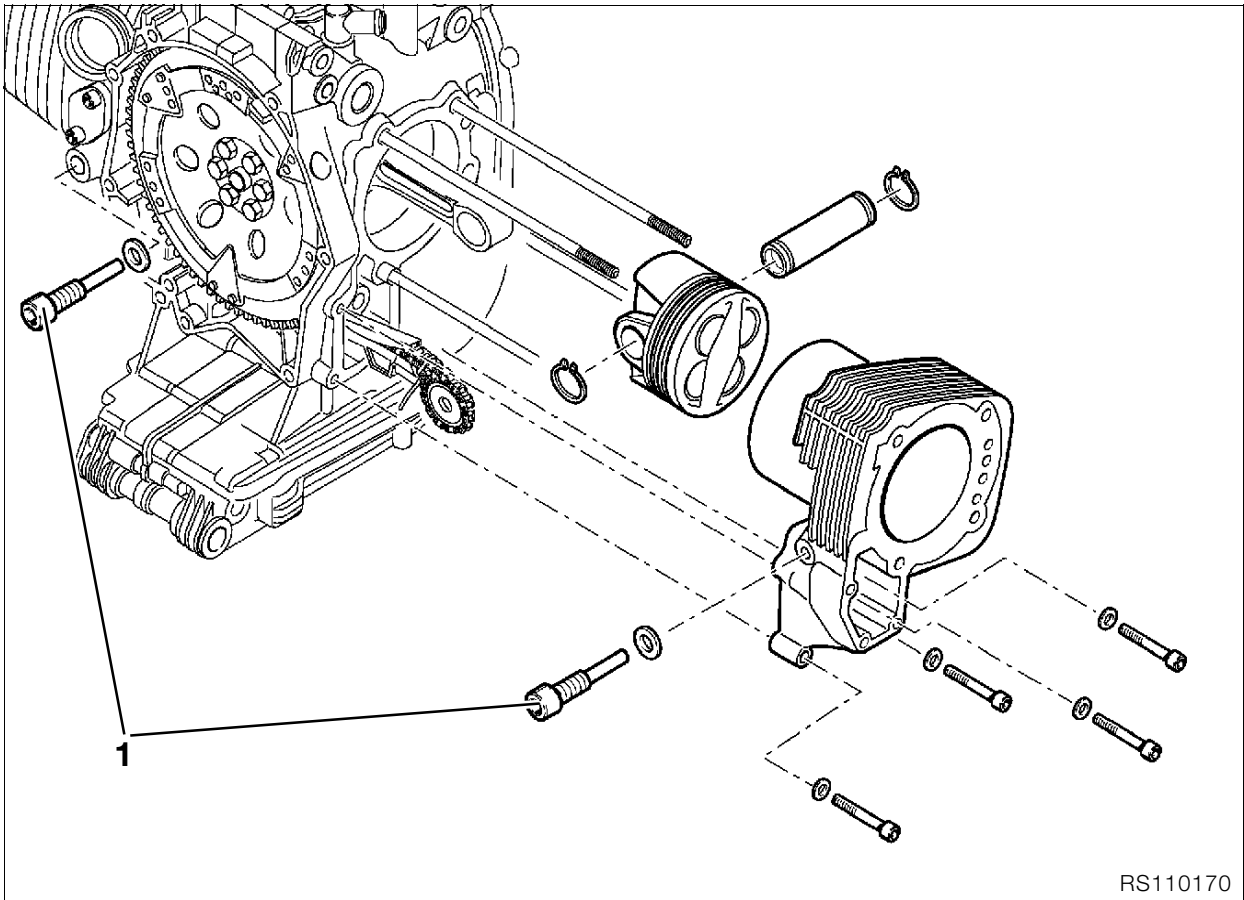

Removing cylinder barrel

- Unscrew and remove guide rail bearing screw (1).
- Unscrew and remove cylinder retaining screws, and remove cylinder.

⚠ Caution:

When removing cylinder, ensure that the piston does not strike the engine block.

Removing/dismantling piston

- Remove both retaining rings on piston pin.
- Press out piston pin by hand.
- Remove piston.
- Carefully remove piston rings with piston ring pliers.
- Remove carbonized oil from base of piston/clean the piston.

⚠ Caution:

Do not accidentally confuse pistons, piston pins or piston rings.

Checking pistons and cylinders

Reference

temperature for measurements:20 °C (68 °F)

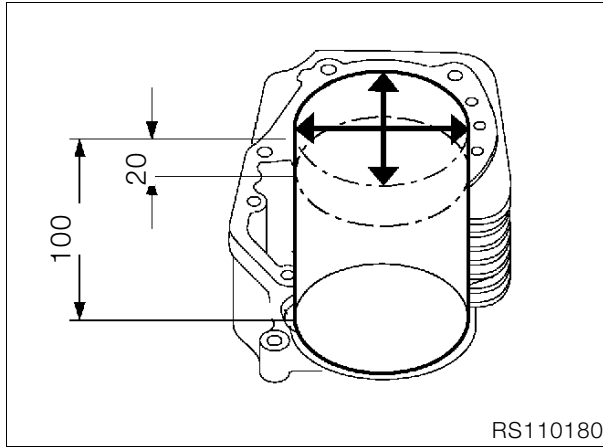

- Measure cylinder bore with internal probe at 20 mm (0.79 in) and 100 mm (3.94 in) from the top in direction of piston pin, and again at a right angle to the first measurement.

➡See Technical data

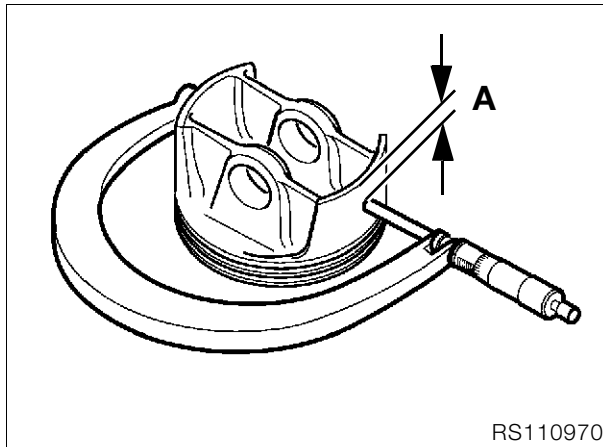

Measuring plane A:..... 6 mm (0.24 in)

➡See Technical data

- Install piston rings in cylinder.

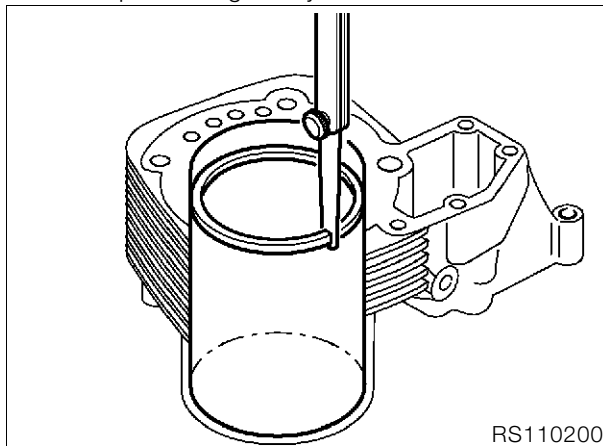

- Determine piston ring clearance using feeler gauge.

➡See Technical data

Assembling pistons

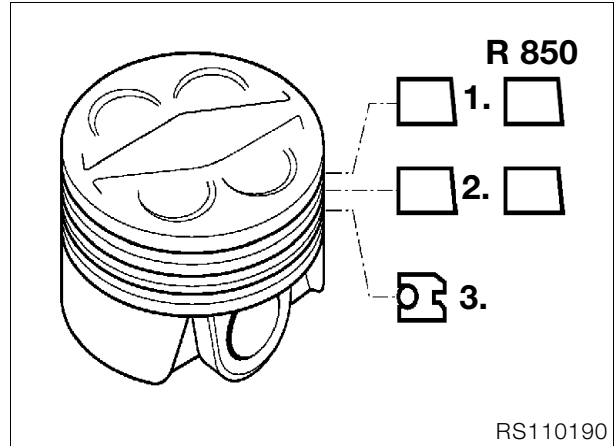

- Carefully fit piston rings to piston in the following sequence, using piston ring pliers:
3rd groove - equal chamfer ring
2nd groove - micro-chamfer ring
1st groove - asymmetric, convex oval-section
- ➡See Technical data

⚠ Caution:

The tubular-spring ring gap must be at 180° to the equal-chamfer ring gap.
Install with "Top" uppermost.

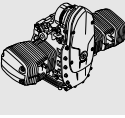

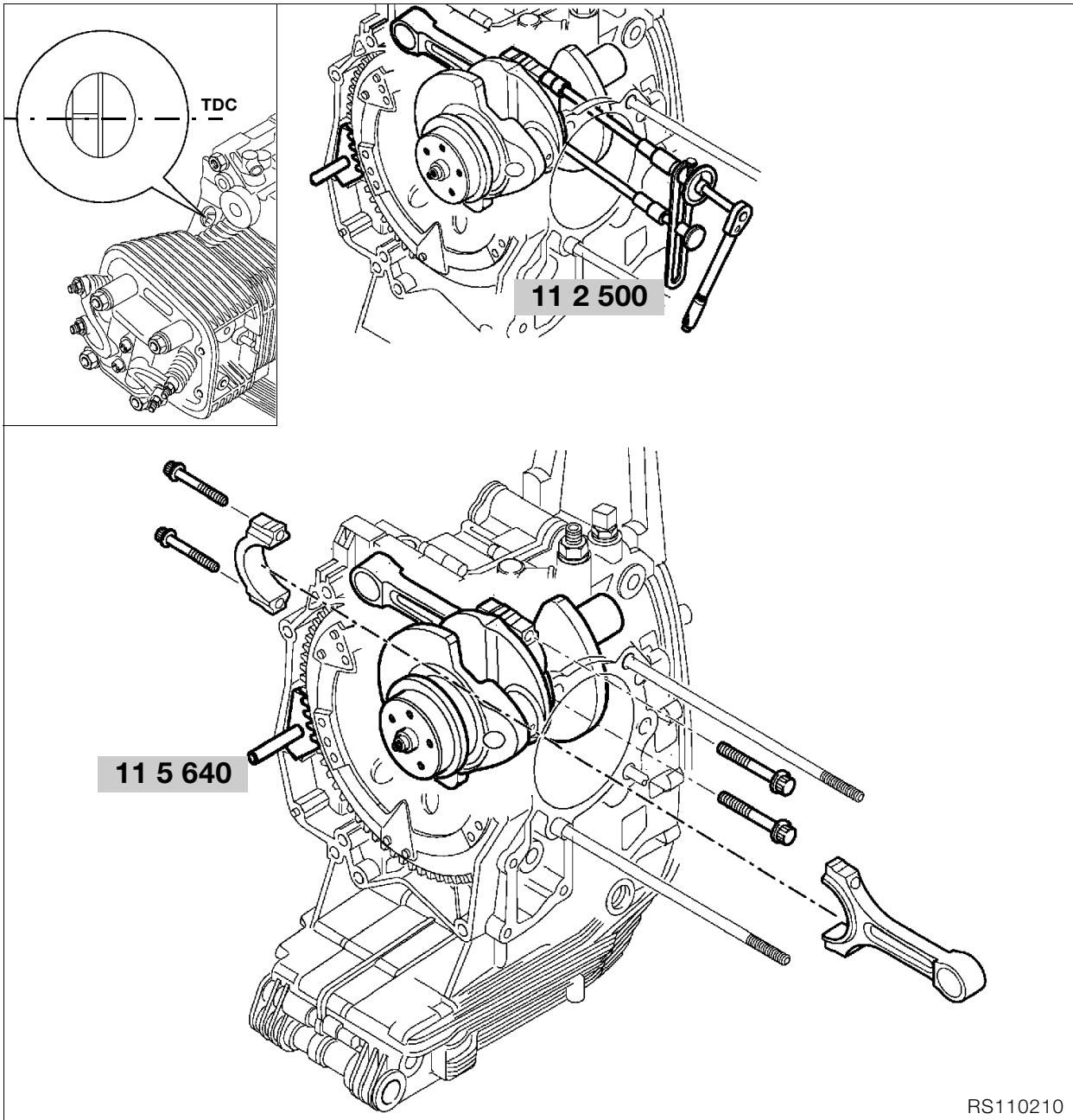

Removing/installing conrod

- Turn crankshaft to TDC position.
- Lock the clutch housing with special tool **BMW No. 11 5 640**.
- Remove conrod.



Note:

Conrods can also be removed/installed with the crankshaft removed.



Caution:

Do not accidentally interchange conrods or bearing shells.

- Install conrods.

Installed direction of conrods: ..lettering facing up



Caution:

Oil the bearings.

- Screw the big end bolts in by hand, then tighten them with a tightening angle indicator, **BMW No. 11 2 500**.



Caution:

Use big end bolts once only.



Tightening torque:

Big end bolts oiled
 Joint torque..... 20 Nm
 Wrench angle 80 °

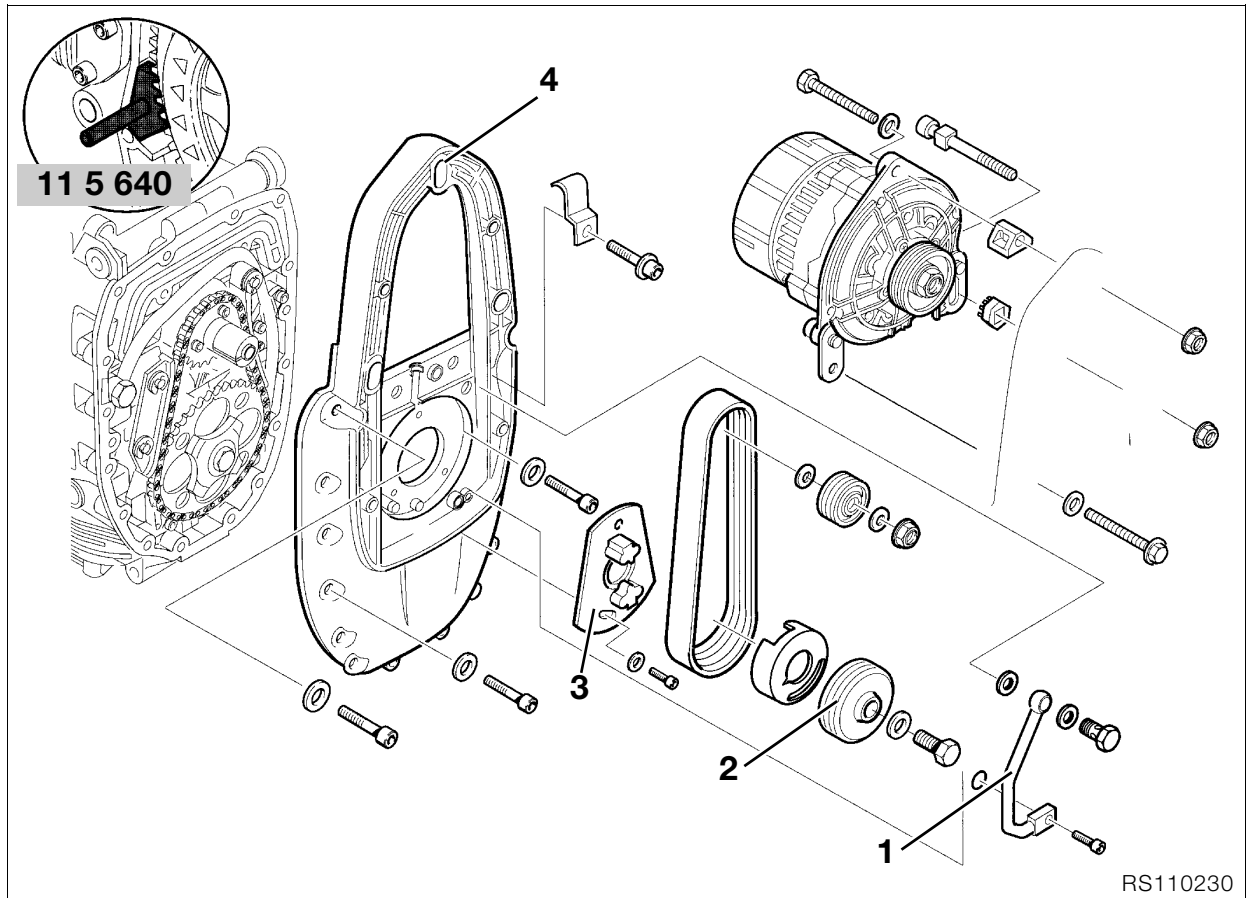

RS110230

Removing and installing alternator cover with engine installed

Caution:

Disconnect earth (ground) lead from battery.
Insulate earth (ground) lead.

- Detach the horn.
- Remove the oil cooler line.
- Separate the Hall-effect signal transmitter plug.
- Remove the starter motor.
- Remove rear leading link mount.

Removing alternator mount cover

- Detach the alternator.
- Remove rotary breather line (1).
- Lock the clutch housing with special tool **BMW No. 11 5 640**.
- Remove pulley (2).
- Remove magnetic gate (3).

Note:

If complete alternator mount cover is removed, leave magnetic gate (3) installed.

- Remove alternator mount cover (4).

Renewing radial shaft seal in alternator mount cover

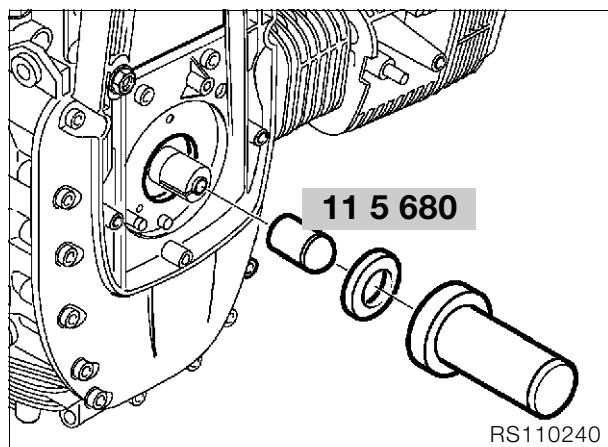

- Carefully lever radial shaft seal out, using a screwdriver.
- Drive in the new radial shaft seal with drift and sliding sleeve, **BMW No. 11 5 680**.



Note:

Slide new radial shaft seal over taper on sliding sleeve, pre-shape and pull off.

Renewing radial shaft seal for rotary breather

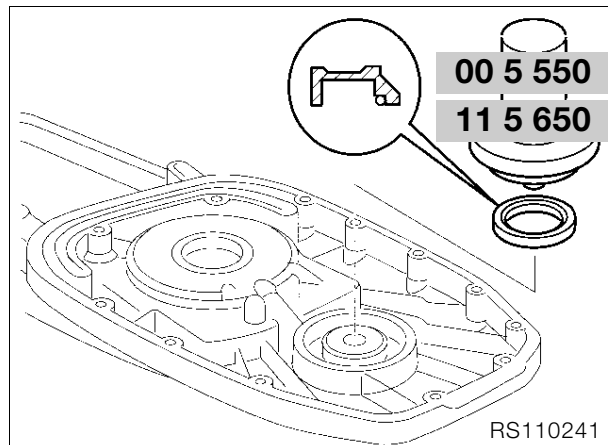

- Carefully lever radial shaft seal out, using a screwdriver.
- Carefully pre-form the lip of the radial shaft seal by hand.
- Oil the new radial shaft seal lightly and drive it in with handle, **BMW No. 00 5 550**, and drift, **BMW No. 11 5 650**.

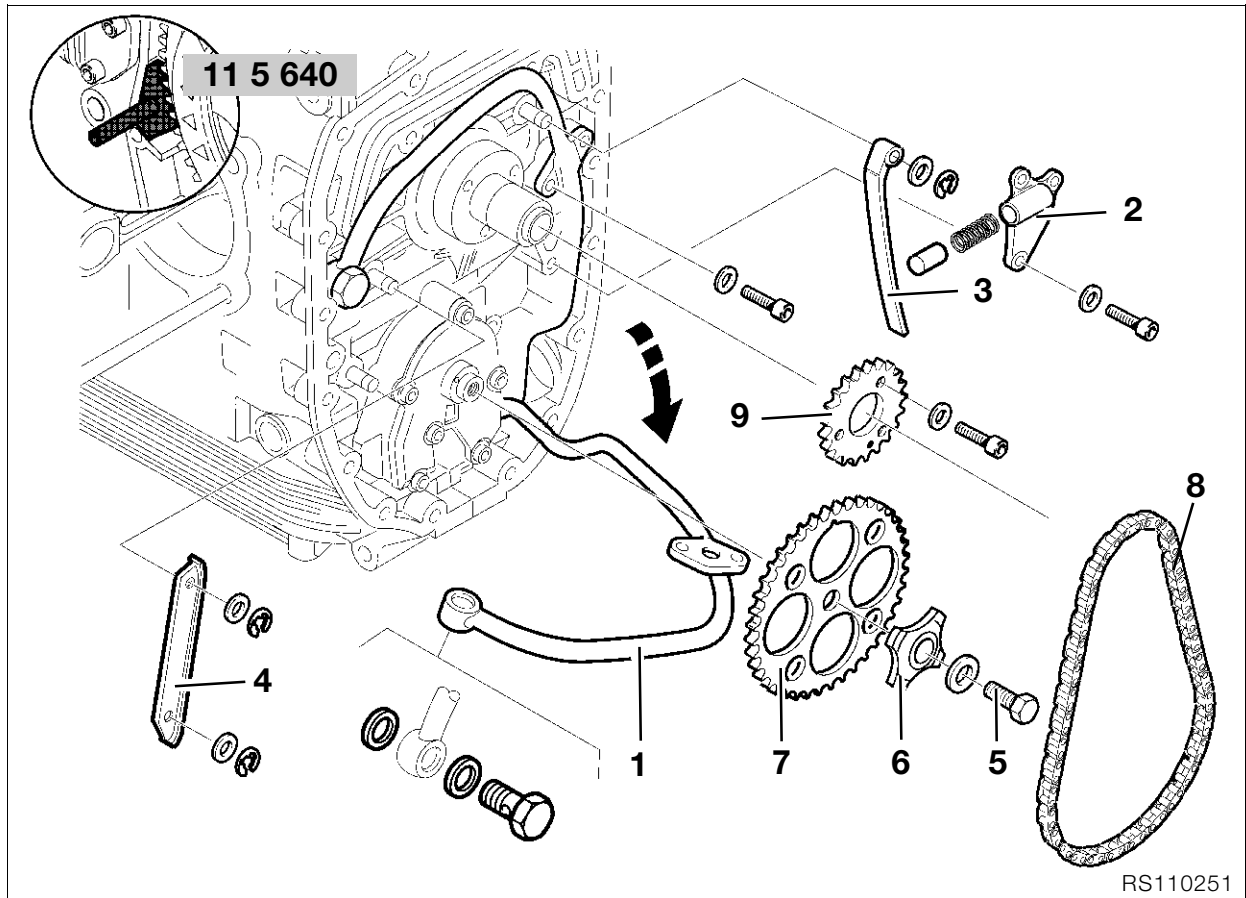

RS110251

Removing auxiliary shaft drive

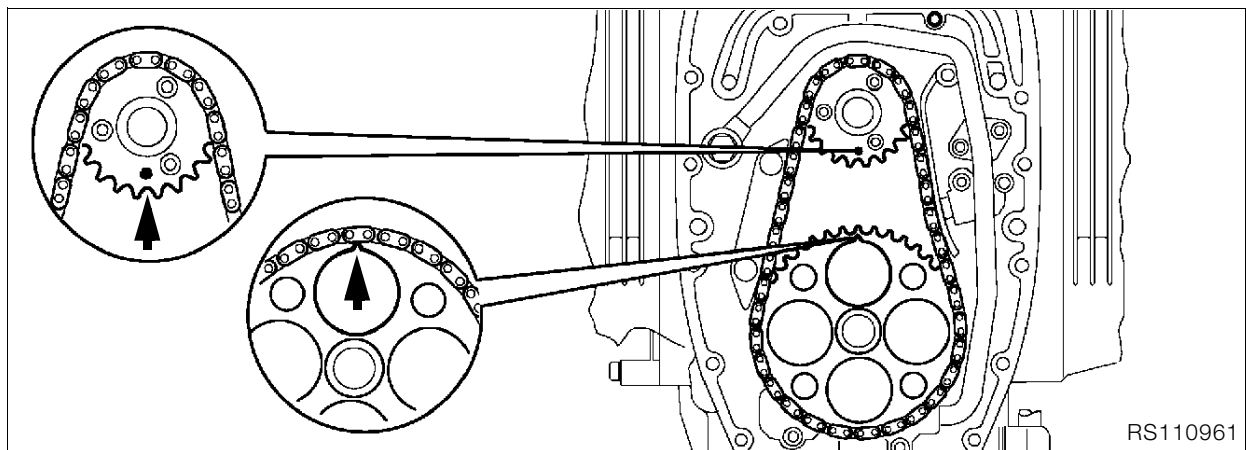

RS110961

- Align markings (arrows) on timing pinion and chain sprocket.
- Unscrew and remove cooling oil pipe (1)/swing the pipe forwards.
- Remove chain tensioner (2).
- Remove chain tensioning rail (3).
- Remove chain guide rail (4).
- Lock clutch housing with special tool **BMW No. 11 5 640**.
- Unscrew and remove chain sprocket retaining bolt (5).
- Remove rotor (6) with chain sprocket (7) and timing chain (8).
- If necessary, remove chain sprocket (9).

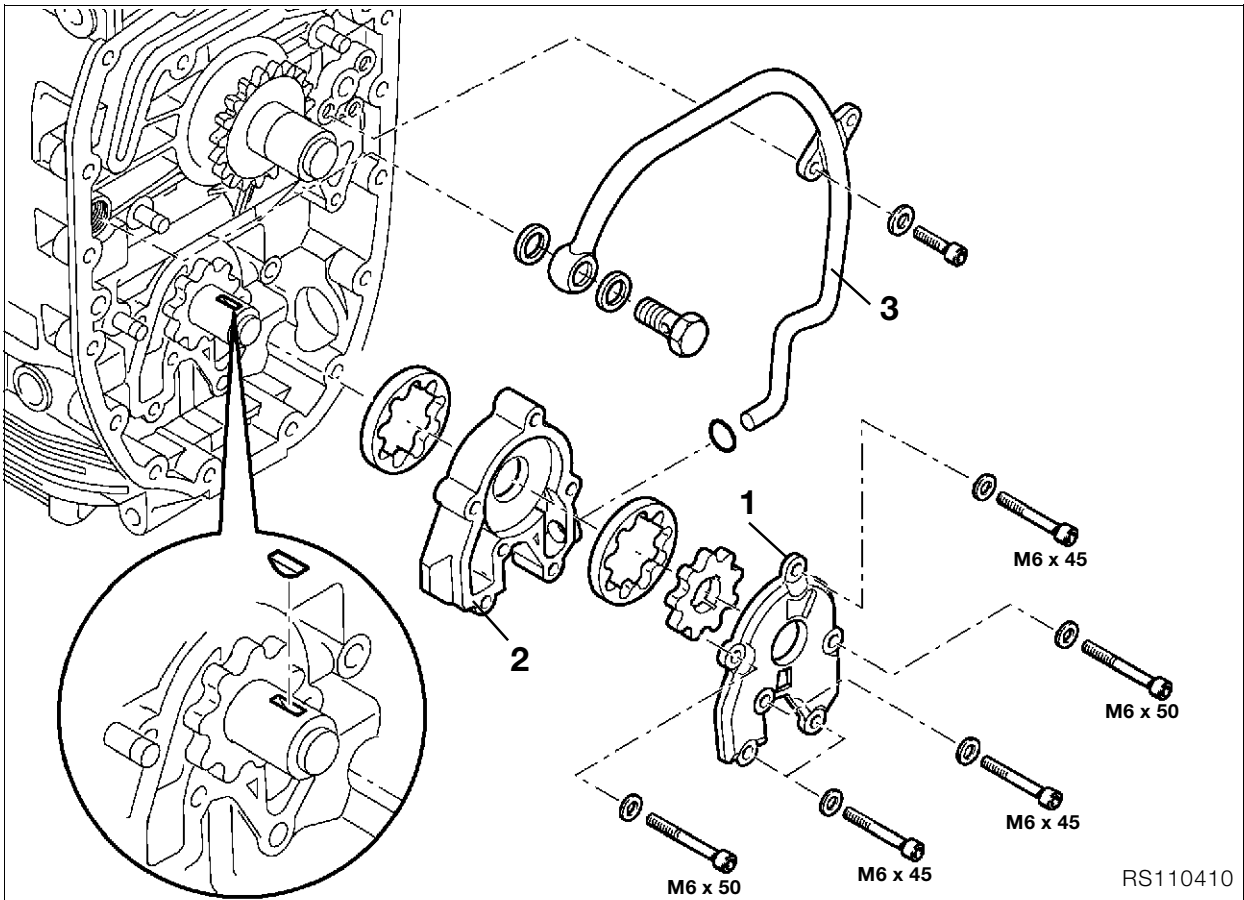

Removing oil pump

- Remove oil pump cover (1).
- Remove complete oil pump (2) together with cooling oil pipe (3), and dismantle.



Caution:

Check installed positions of parts which have already been run together.

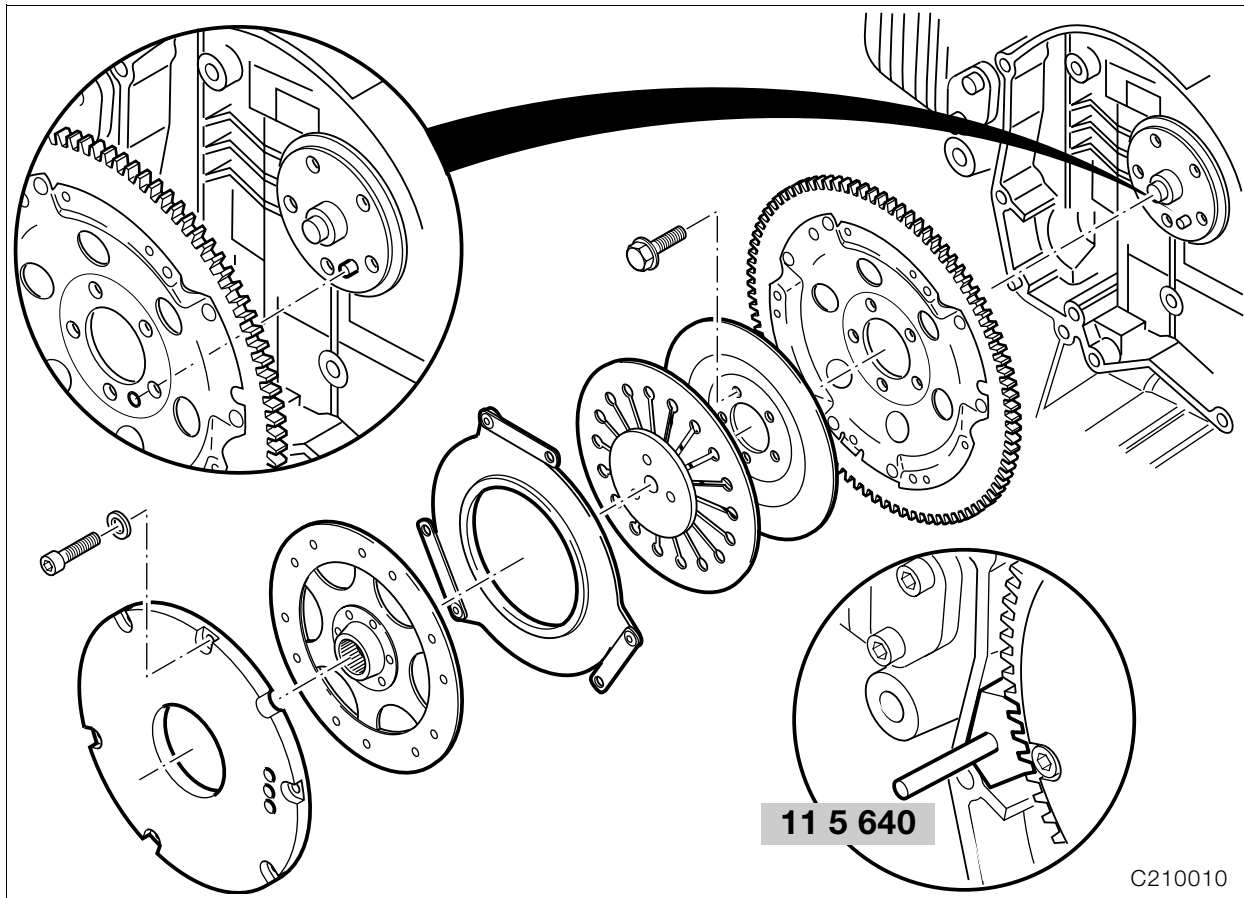

Removing radial shaft seal on crankshaft with engine installed

- Lock clutch housing with special tool **BMW No. 11 5 640**.
- Remove the clutch.

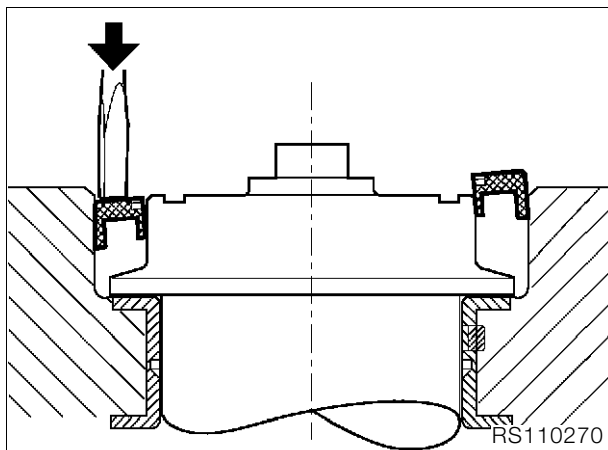

- Carefully lever radial shaft seal out, using a screwdriver.



Caution:

Avoid damaging the sealing faces on the housing and the crankshaft.



Note:

When the crankcase is dismantled, the radial shaft seal can be taken out.

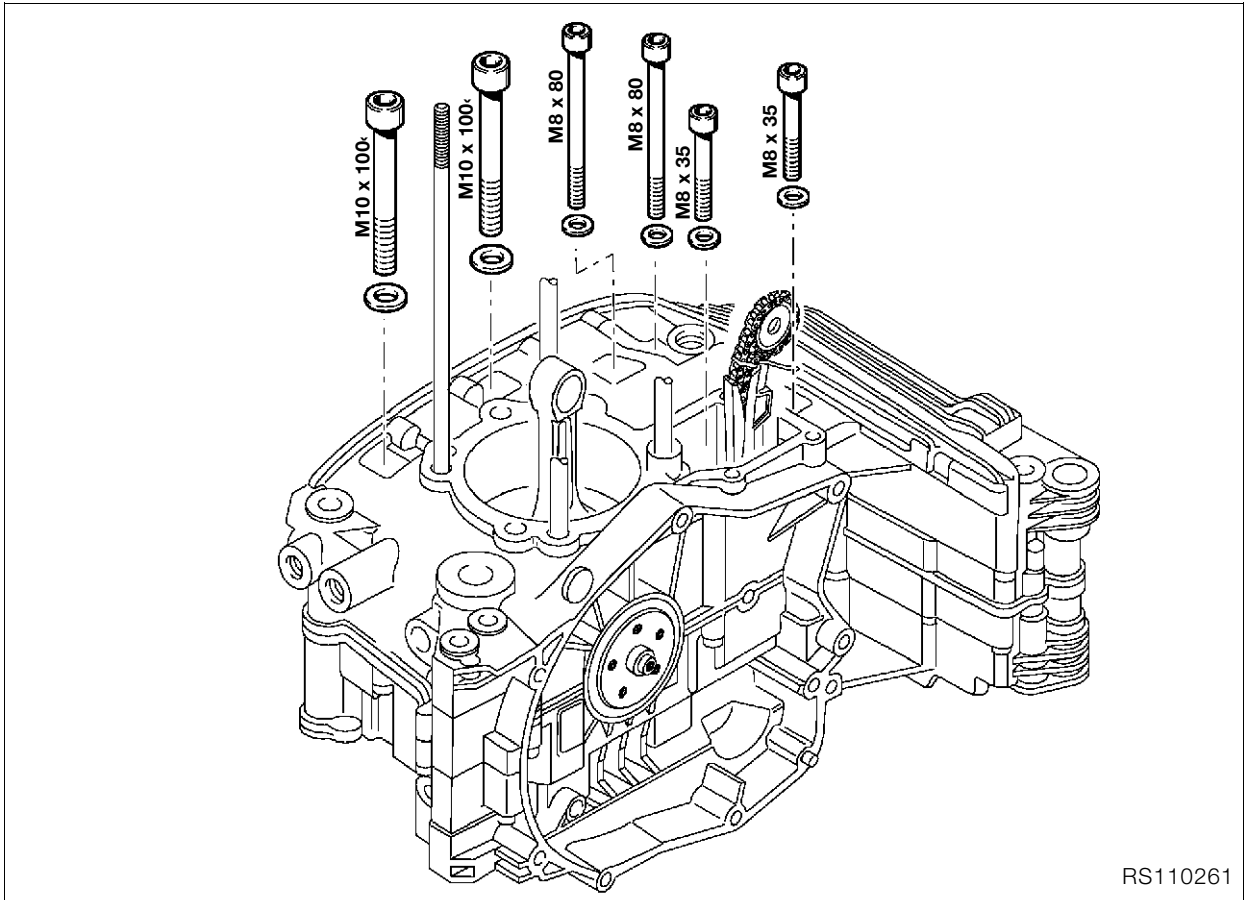
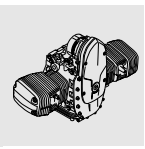

RS110261

Dismantling crankcase

- Turn engine on to its side.
- Remove screws on right side.

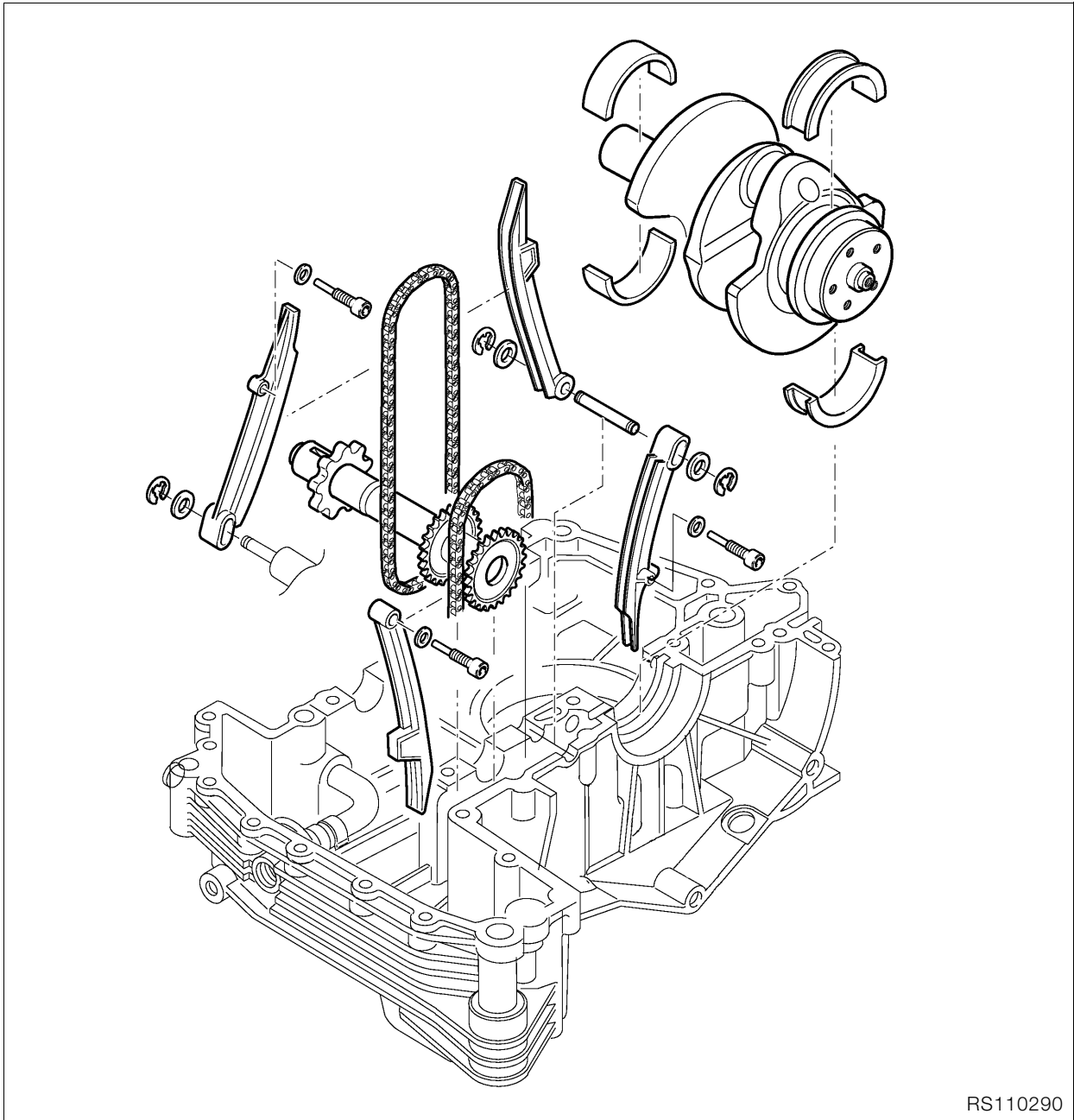
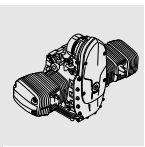

RS110290

Removing crankshaft, auxiliary shaft
and timing chain tensioning and slide
rails

Removing and installing oil pick-up basket

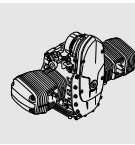
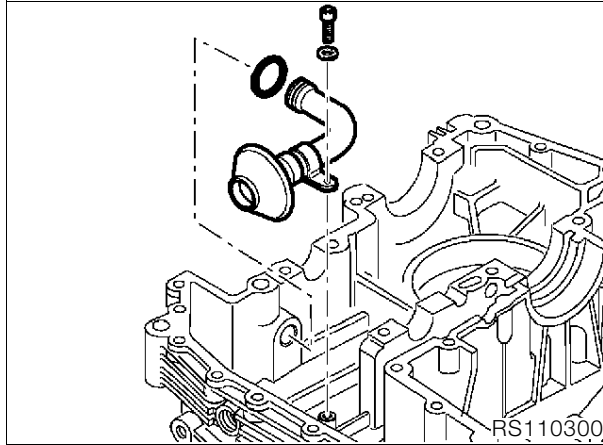

 **Tightening torque:**
M 6 screw 9 Nm

 **Caution:**
Make sure that the O-ring is not omitted, and is installed undamaged.

Replacing oil level sight glass

- Pierce the plastic disc with a large screwdriver and lever out the oil level sight glass.
- Coat the sealing face of the new oil level sight glass with engine oil and drive it in with drift, **BMW No. 00 5 550.**

Removing conrods

- Clamp crankshaft in a vise provided with protective jaws.
- Remove conrod.

 **Caution:**
Do not accidentally confuse the conrods.

Checking conrods

- Check conrod dimensions.
➡ See Technical data

 **Caution:**
Sintered-metal conrods must never be straightened – risk of fracture.

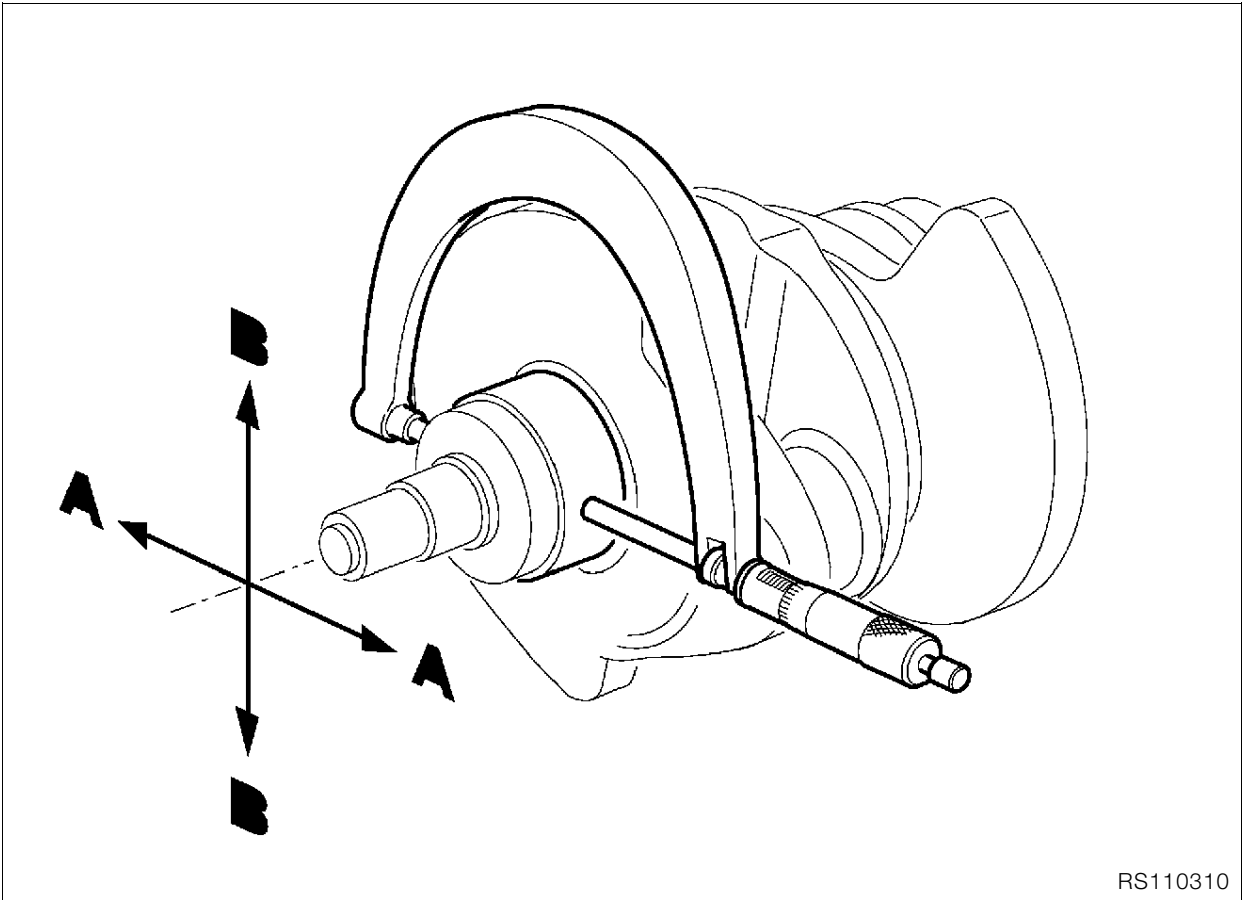
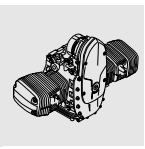

RS110310

Measuring main and big end bearing play

Measuring radial bearing play

- Measure main bearing journal with an external micrometer crosswise in two planes, A and B.
 - Enter measured values on record sheet.
- ➡See Technical data



Caution:

The crankshaft can only be reground in grinding stage 0; after this it must be rehardened and finished. Grinding stages are identified by a paint mark on the front crank web.

➡See Technical data

If the bearing shells have to be replaced, note colored marks on crankpins and big end bearings.

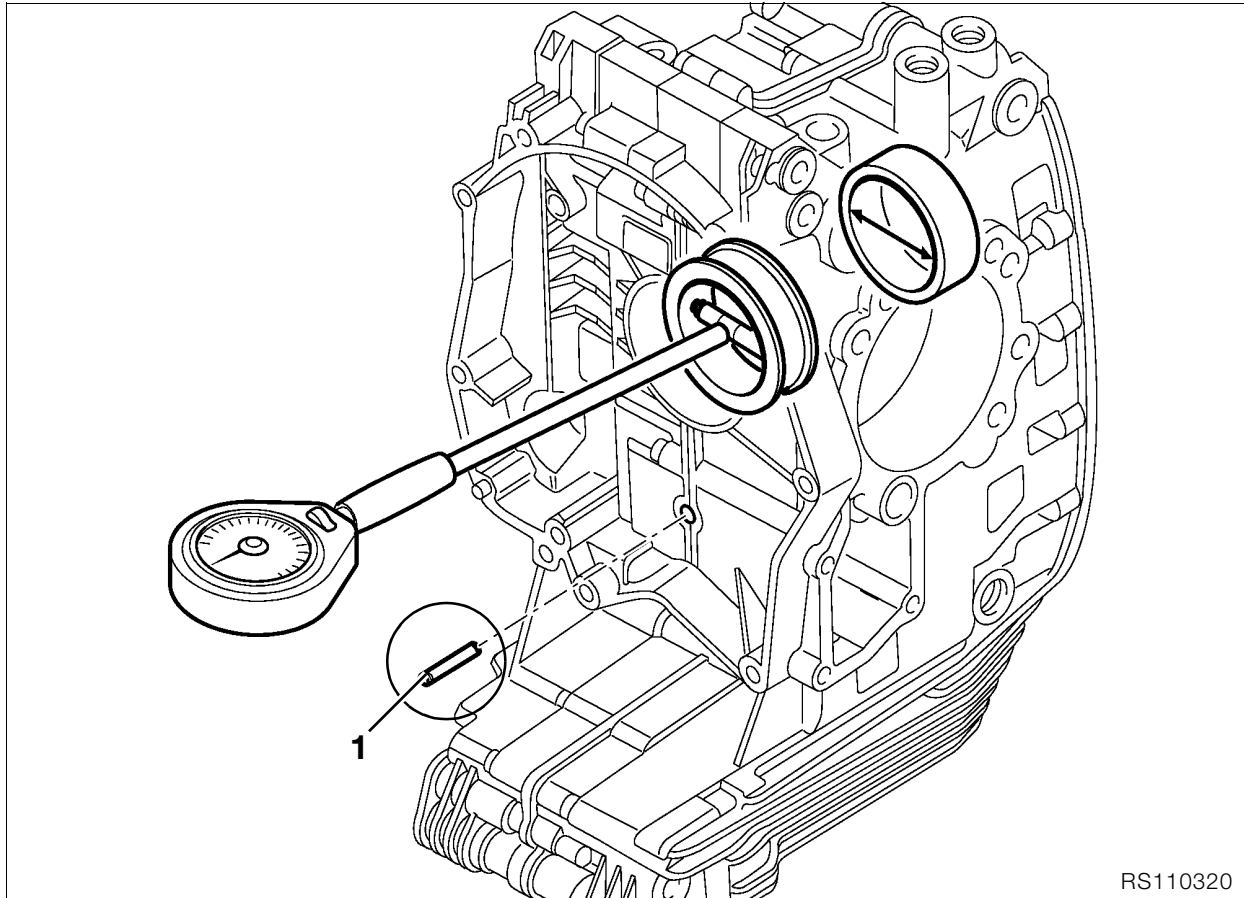

RS110320

Installing main bearing

- Insert tensioner rail/slide rail pivot pin (1) for centering purposes.
- Tighten M8 and M10 housing screws.

Tightening torque/tightening order:

1. M 10 screw (oiled) 45 Nm
2. M 8 screw (oiled) 20 Nm

- Measure main bearings front/back in the load direction.
- Enter measured values on record sheet and determine main bearing play values.

➡See Technical data

Measuring axial bearing play

- Place crankshaft in engine block.
- Insert tensioner rail/slide rail pivot pin (1) for centering purposes.
- Tighten housing screws.

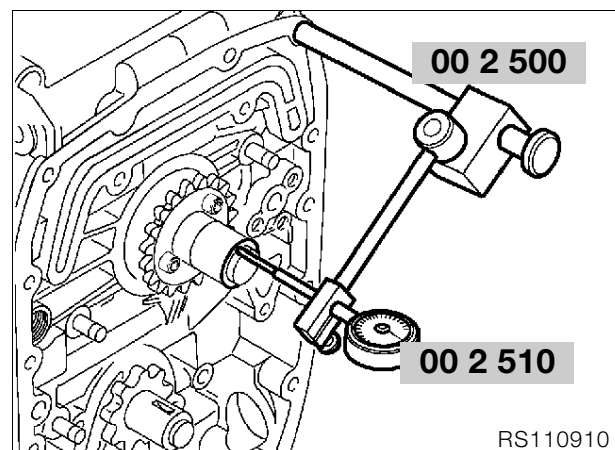

RS110910

- Screw measuring device, **BMW No. 00 2 500**, with dial gauge, **BMW No. 00 2 510**, into tapped hole for alternator carrier cover.
- Move crankshaft forwards and backwards and read off play at dial gauge.

➡See Technical data

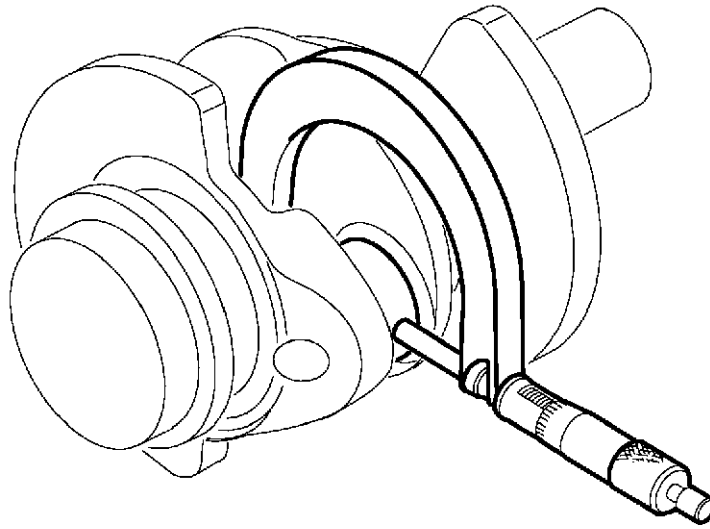
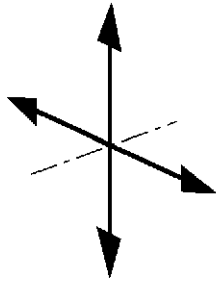

RS110340

Measuring big end bearing play

- Measure crankpin with an external micrometer in the thrust direction and offset through 90°.

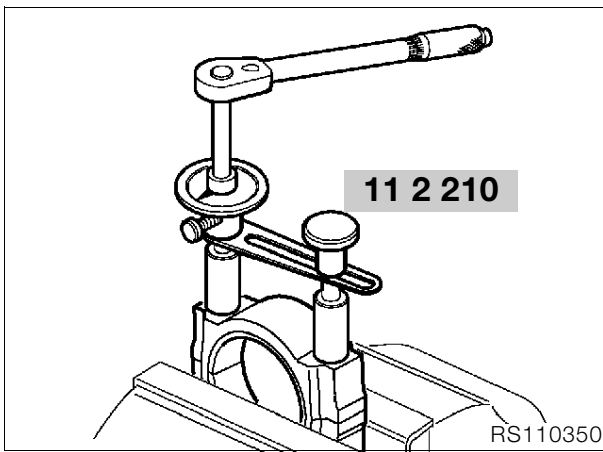

RS110350

- Install bearing shells and assemble conrods.
- Using tightening angle gauge, **BMW No. 11 2 210**, tighten the big end bolt.

Tightening torque:

Big end bolts oiled
 Joint torque 20 Nm
 Wrench angle 80°

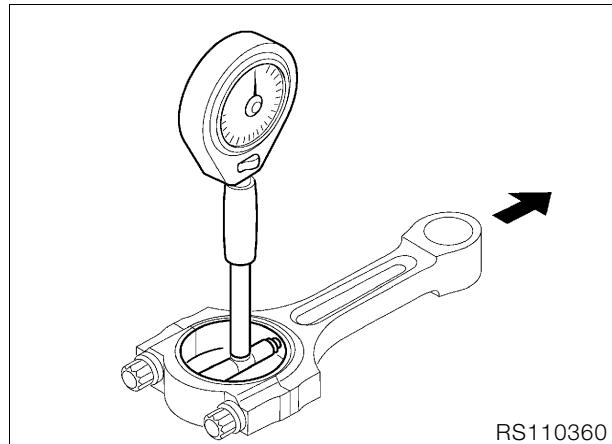

RS110360

- Measure big end bearing with internal gauge in thrust direction.
 - Enter measured values on record sheet and determine big end bearing clearances.
- ➡ See Technical data

Assembling engine

Installing conrod

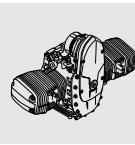
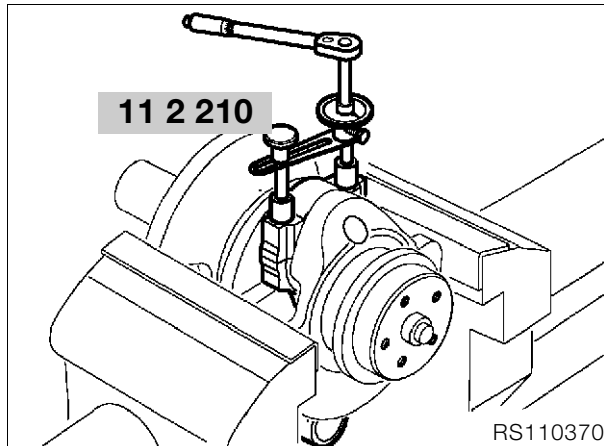

- Clamp crankshaft in a vise provided with protective jaws.
- Oil the big end bolts, screw them in by hand and tighten with angle gauge, **BMW No. 11 2 210**.



Caution:

Oil the bearings.
Do not accidentally confuse conrods or bearing shells.
Always use new big end bolts.

Installed direction of conrods: ..lettering facing up



Tightening torque:

Big end bolts (oiled)
Joint torque..... 20 Nm
Wrench angle 80°

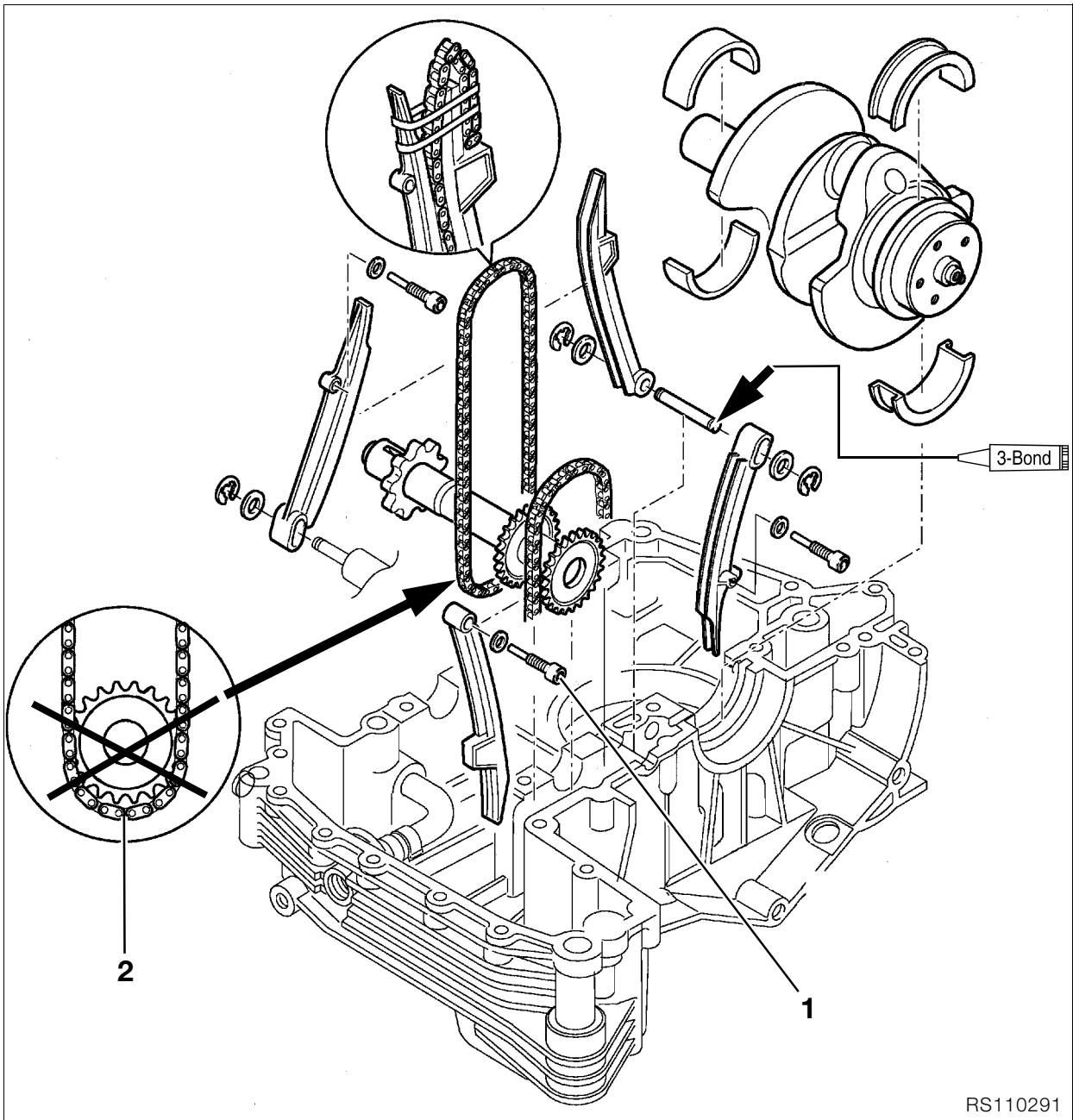

RS110291

Installing crankshaft

⚠ Caution:
Oil the bearings.

Installing auxiliary shaft/timing chains

⚠ Caution:
Timing chains (2) must mesh fully with auxiliary shaft sprockets.

Installing timing chain tensioning and slide rails

- Seal pivot pin for tensioning rail/slide rail at clutch side (arrow) with **3-Bond 1209**. Insert pivot screw (1) into chain tensioner rail, using a new seal.

⚠ Tightening torque:
Chain guide rail pivot pin 18 Nm

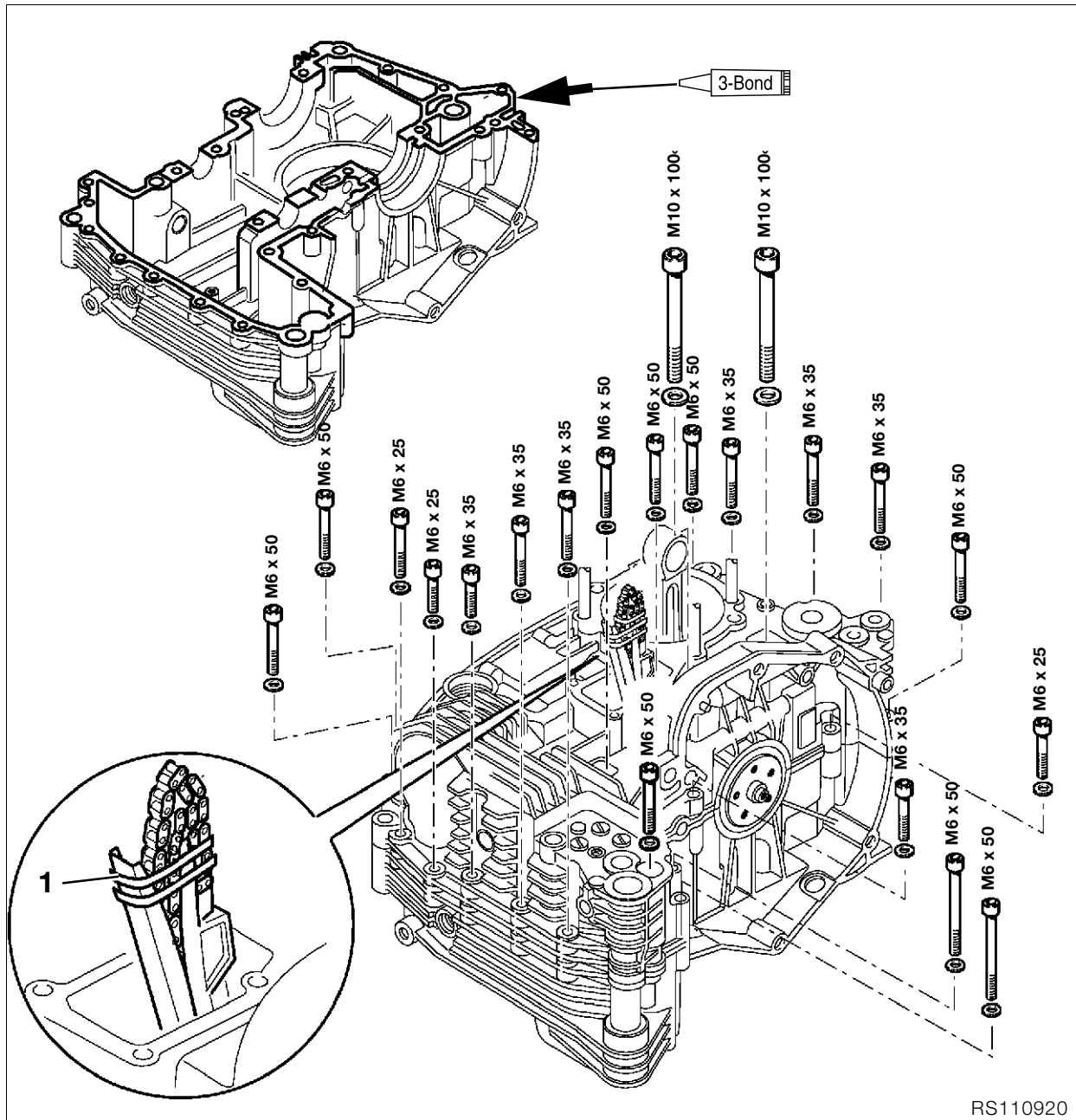

Assembling engine block

- Coat clean, grease-free sealing faces (arrow) with **3-Bond 1209**.
- Secure the timing chain with rubber band (1) to the timing chain tensioning and slide rail.

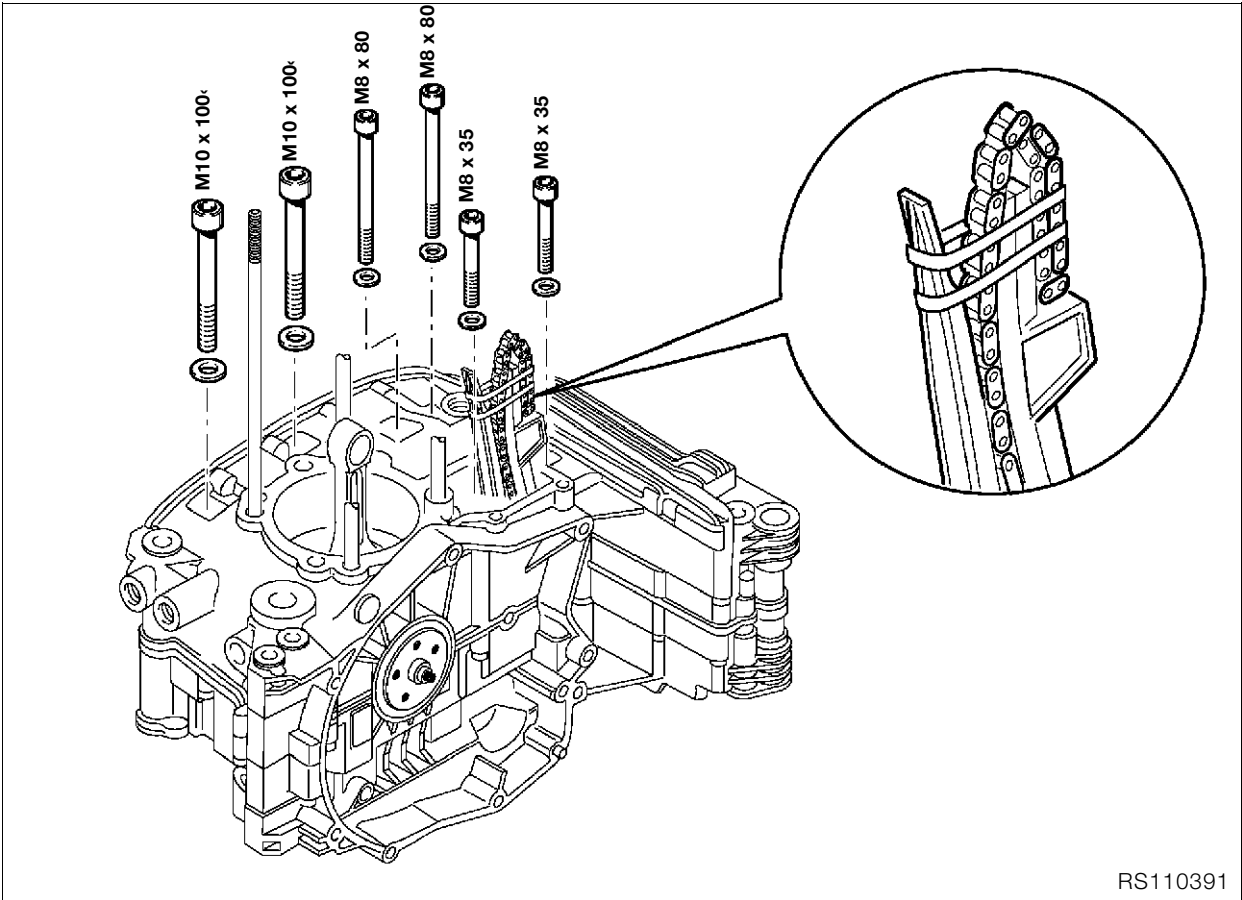
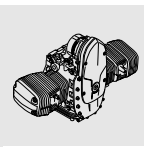

RS110391

- Bolt the crankcase sections together.

 **Tightening torque/tightening order:**

1. M10 screw (oiled) 45 Nm
2. M 8 screw (oiled) 20 Nm
3. M 6 screw 9 Nm

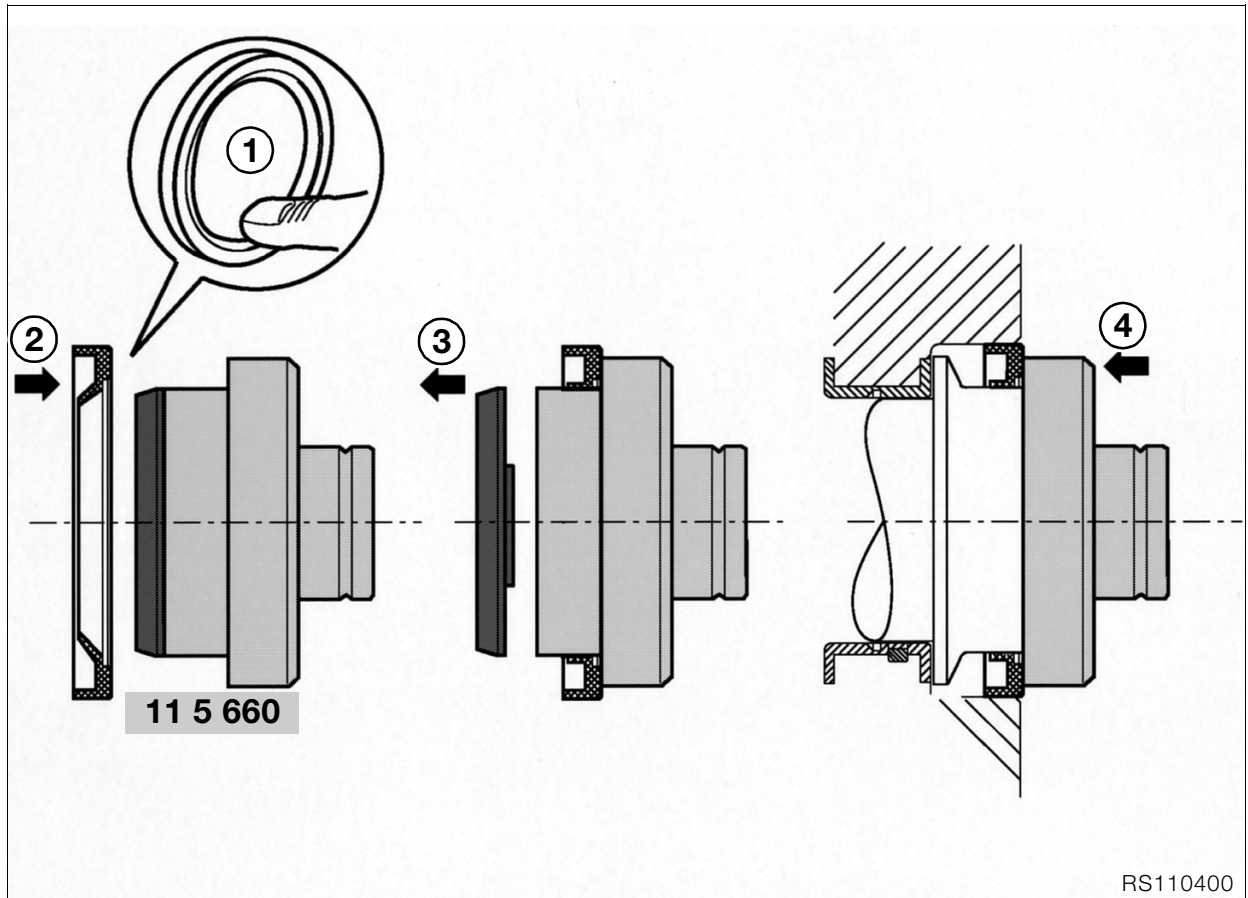

RS110400

Installing the crankshaft radial seal

- Pre-form the lip of the radial shaft seal carefully by hand (1).
- Oil the radial shaft seal at the sealing/contact surface.
- Place radial seal over sliding sleeve (2)/remove sliding sleeve (3).
- Drive the radial shaft seal in with handle, **BMW No. 00 0 500**, and drift with sliding sleeve, **BMW No. 11 5 660** (4).

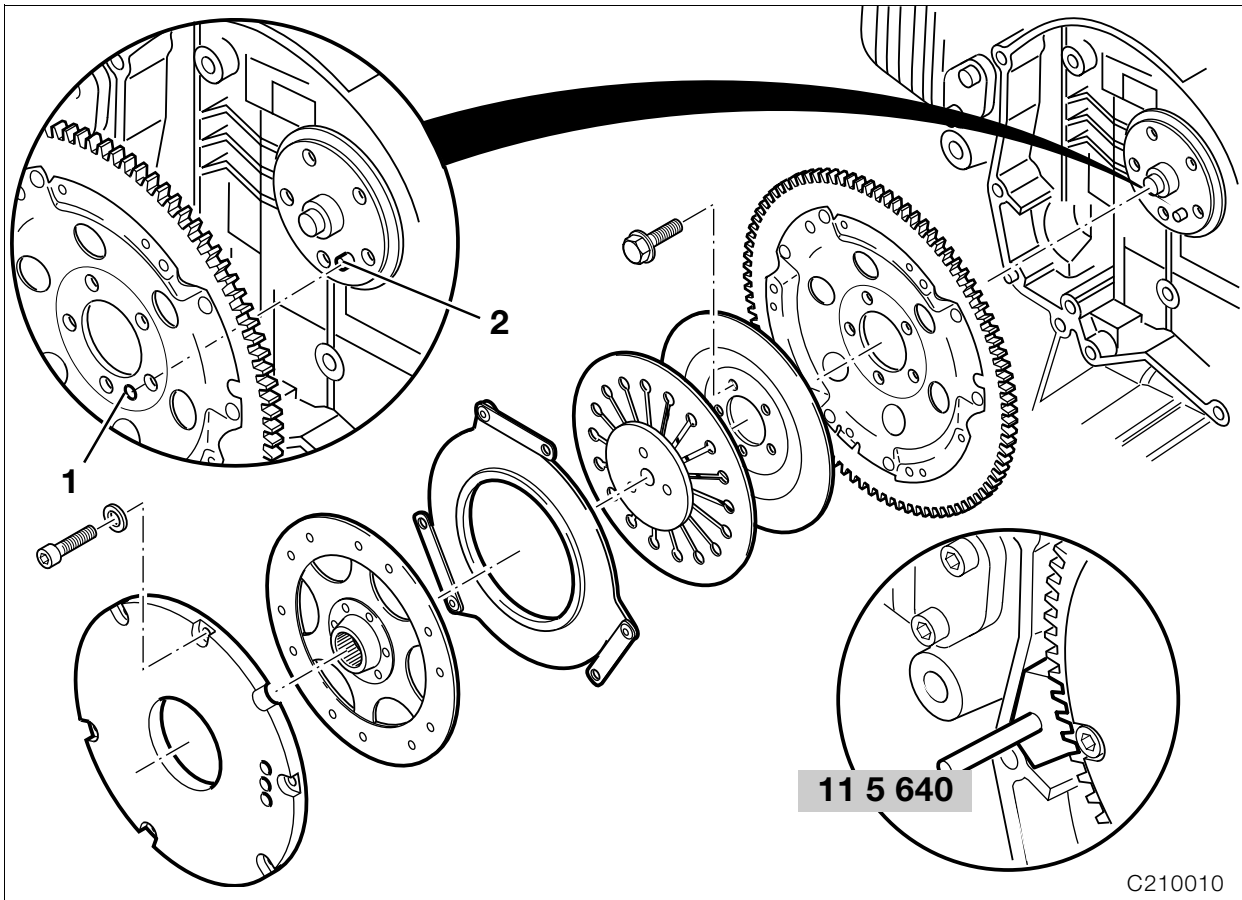

Installing clutch housing



Caution:

Always use new bolts for housing and cover.

- Install clutch housing with mark (1) aligned with crankshaft mark (2).
- Lock the clutch housing with special tool **BMW No. 11 5 640**.
- Insert all screws by hand and tighten down.



Tightening torque:

Clutch housing
 to crankshaft (screw threads oiled) 40 Nm
 Additional wrench angle 32°

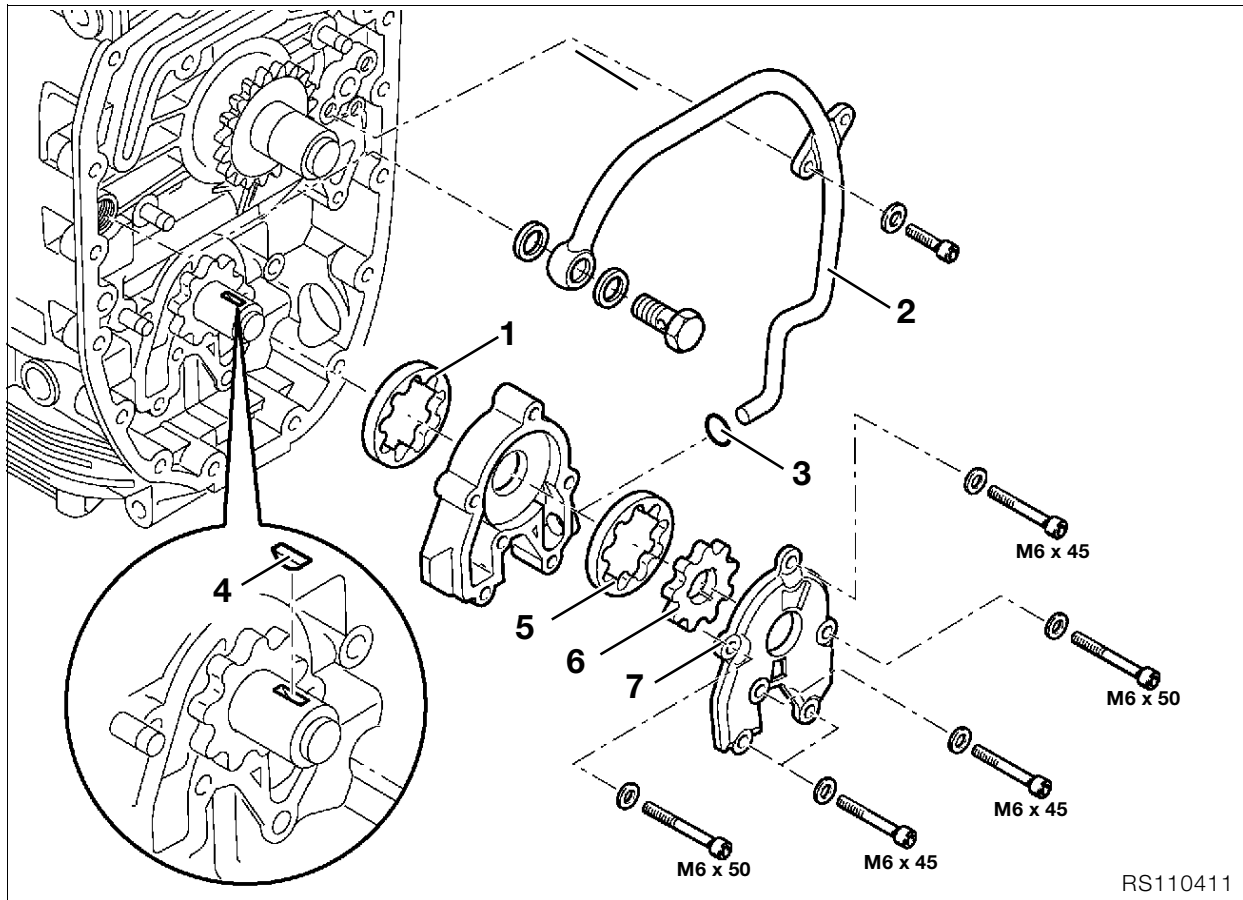

Installing oil pump



Caution:

Oil the sliding-contact faces.

- Install outer rotor (1) of oil pump in pump housing.
- Install oil pump housing with cooling oil pipe (2).



Caution:

O-ring (3) must be in good condition.

- Install Woodruff key (4), outer rotor (5) and inner rotor (6) in cooling oil pump.
- Screw housing cover (7) on to oil pump.



Caution:

Note different lengths of screw.



Tightening torque:

M 6 screw	9 Nm
Pressure relief valve	35 Nm
Oil pressure switch.....	30 Nm

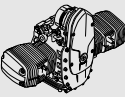

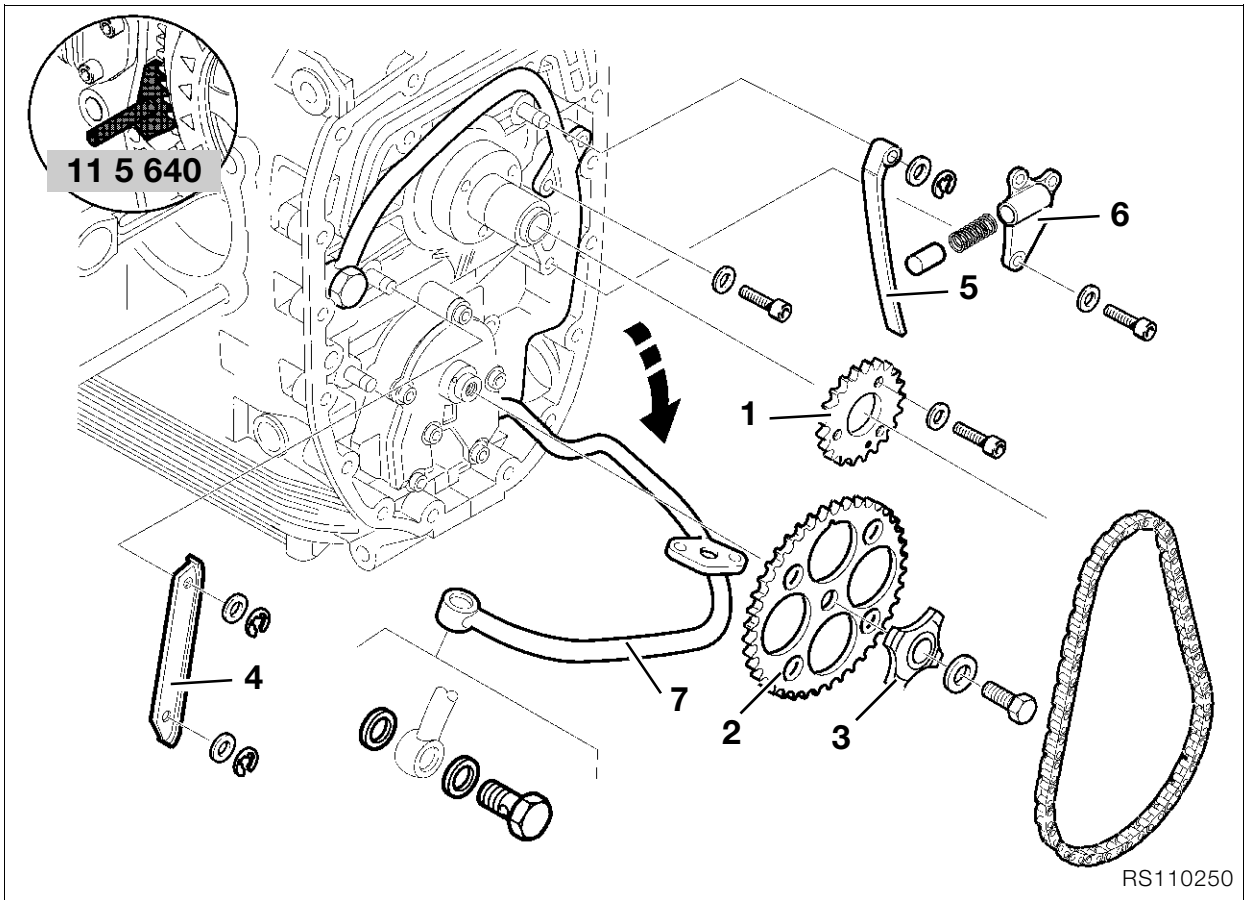

Installing auxiliary shaft drive

- Set crankshaft mark against mark on auxiliary shaft.

Caution:

Adjust according to the adjusting instructions.
 ➔ See "Installing cylinder head".

- Lock the clutch housing with special tool **BMW No. 11 5 640**.
- Install chain sprocket (1).

Tightening torque:

M 6 screw 10 Nm

- Install drive-shaft chain with chainwheel (2) and rotor (3).

Tightening torque:

Retaining screw at chainwheel 70 Nm

- Install/secure chain guide rail (4).
- Install/secure chain tensioner rail (5).
- Install chain tensioner housing (6) with piston and spring.

Tightening torque:

M 6 screw 9 Nm

- Tighten down cooling oil line (7).

Caution:

Use a new sealing ring.

Tightening torque:

M 6 screw 10 Nm

Banjo screw for cooling oil line

with oil vent valve 25 Nm

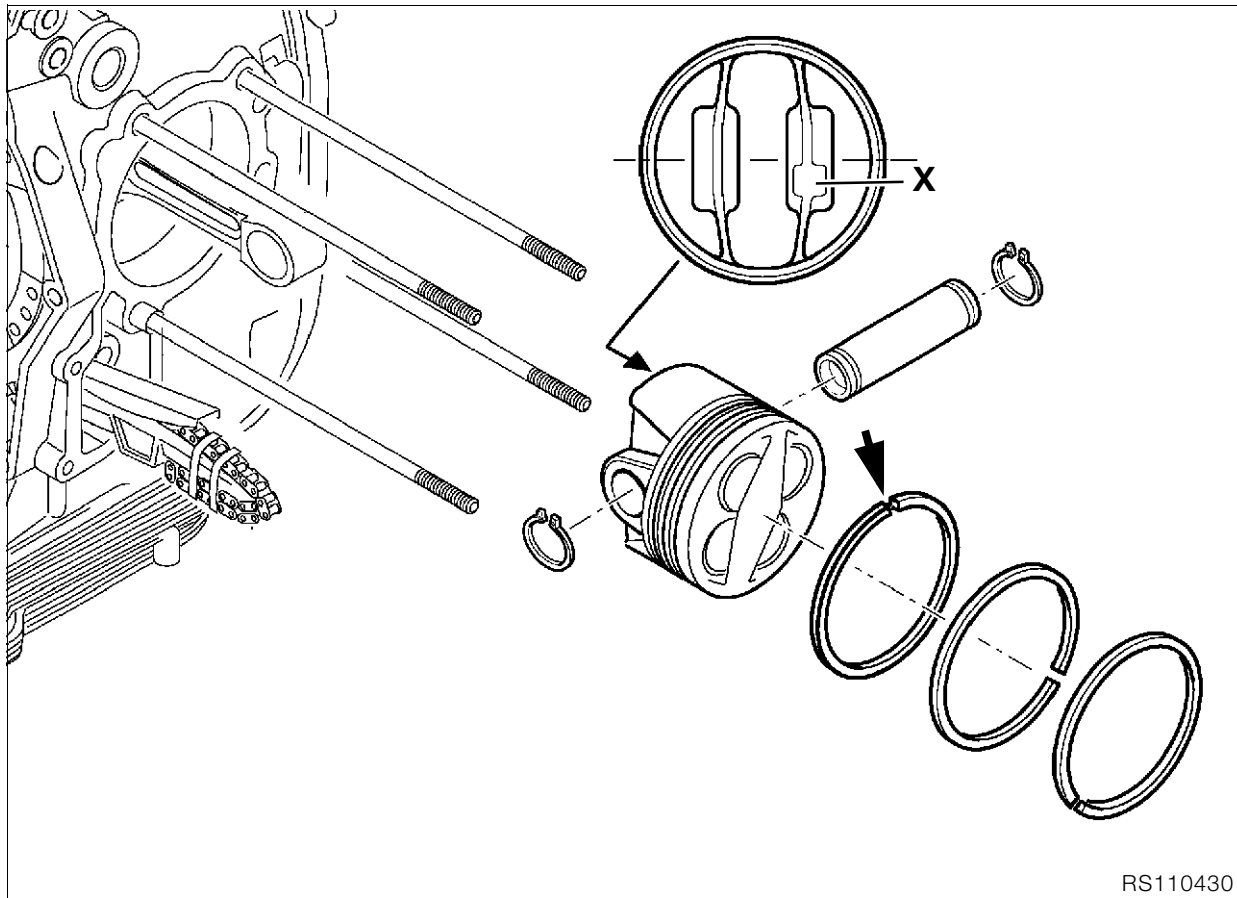

RS110430

Installing piston

- Turn joint in oil scraper ring (arrow) so that it faces upwards.
- Install piston ring gap offset by 120° in each case.

Production locating point **X** = install on exhaust side.



Caution:

Ensure that retaining rings are properly seated on piston pin.
Oil the sliding-contact faces.
Always use pistons of the same weight class in any one engine.

Markings: + or -
 See Technical data



Caution:

Always install pistons and cylinders in pairs.
Do not accidentally confuse pistons or piston pins.

Piston size identification:

On piston crown A, B, AB (for either A or B cylinder),
and on cylinder A, B.

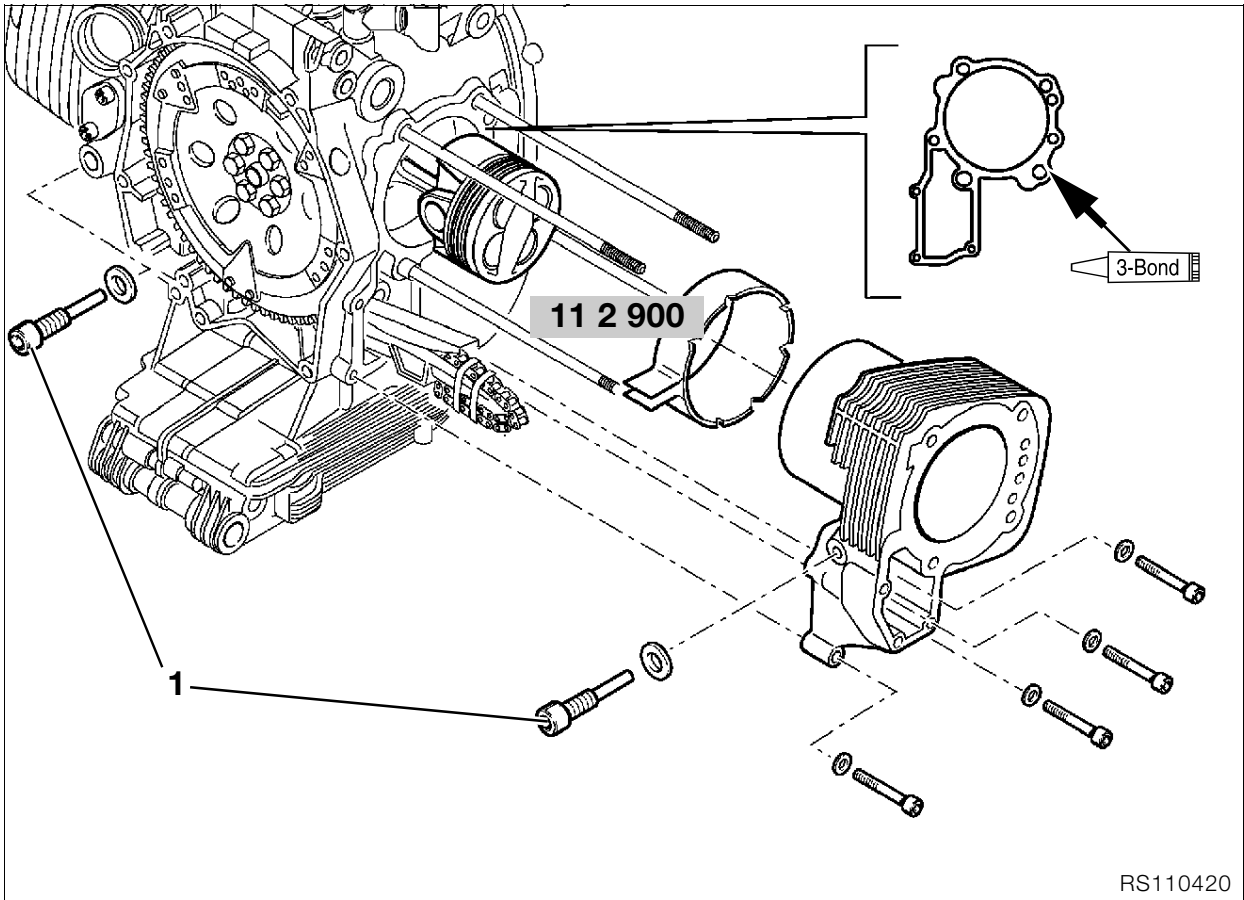

Installing cylinder

- Apply **3-Bond 1209** to the cylinder base sealing face (arrow), which must be clean and free from grease.
- Oil the cylinder wall.
- Compress the piston rings with a clamping strap, **BMW No. 11 2 900**.
- Install the cylinder and at the same time pass the timing chain and the tensioning and guide rail through the timing case cavity.
- Tighten cylinder down firmly.
- Fit new seal to pivot pin for chain guide rail (1).
- Install chain sprocket.

Tightening torque/tightening order:

1. M 8 screw 20 Nm
2. M 6 screw 9 Nm
3. Pivot screw for chain guide rail 18 Nm

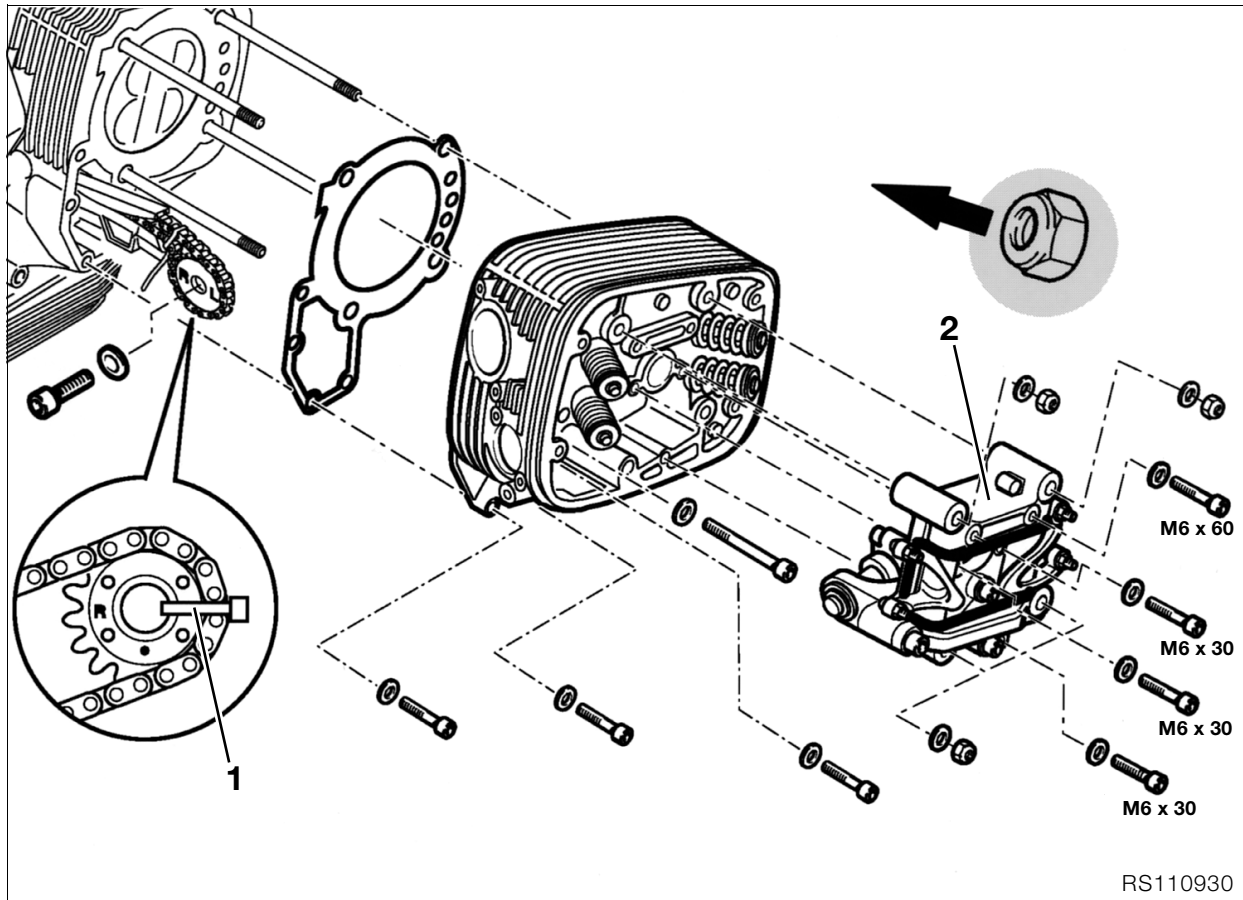

Installing cylinder head

- Install cylinder head gasket.
- Fit cylinder head/insert correctly positioned camshaft chain sprocket (1) and timing chain into chain cavity.
- Install valve gear support (2).
- Tighten cylinder head down.



Caution:

Install collar (arrow) of cylinder head nut towards cylinder head.



Tightening torque/tightening order:

1. Tighten cylinder head nuts (oiled) crosswise
 - 1.1 Tighten all nuts 20 Nm
 - 1.2 Tighten all nuts to correct angle 90°
 - 1.3 Tighten all nuts to correct angle 90°
2. M 10 bolt 40 Nm
3. M 6 screw 9 Nm



Tightening torque:

Take up slack after 1000 km (app. 600 miles)

Tighten cylinder head nuts in a crosswise pattern

1. Unfasten one nut
2. Tighten one nut to initial value 20 Nm
3. Tighten nut to wrench angle 180°
4. Unfasten/retighten M10 screw 40 Nm

- Fit camshaft chain sprocket in accordance with adjustment specification.
- Lock clutch housing with special tool **BMW No. 11 5 640**.
- Tighten camshaft chain sprocket.



Tightening torque:

Camshaft sprocket retaining screw 65 Nm

- Insert the left-side camshaft sprocket with pin into the camshaft and set the left cylinder to TDC on the ignition stroke.
- Fit camshaft chain sprocket in accordance with adjustment specification.
- Tighten camshaft chain sprocket.
- Install chain tensioner.
- Check that marks on camshaft sprockets are in accordance with adjustment specification.



Tightening torque:

Chain tensioner 32 Nm

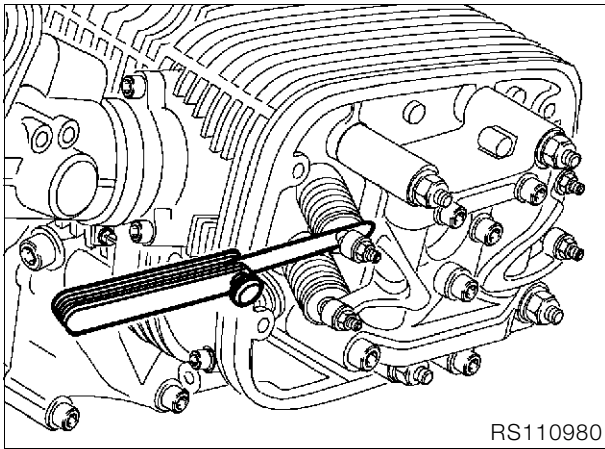

Adjusting valve clearances

- Set piston to TDC on the ignition stroke.
- Measure valve clearance with feeler gauge.
- Correct valve clearance with adjusting screw and lock into position.

Valve clearances with engine cold

(max. 35 °C/95 °F):

Inlet 0.15 mm (0.006 in)
 Exhaust 0.30 mm (0.012 in)



⚠ Tightening torque:

Locknut 8 Nm

- Check valve clearance again; it must be possible to insert the feeler gauge between valve stem and rocker with only slight resistance to movement.

Installing right cylinder head

Adjustment specification



Caution:

When assembling, **always** start with the **right** cylinder.

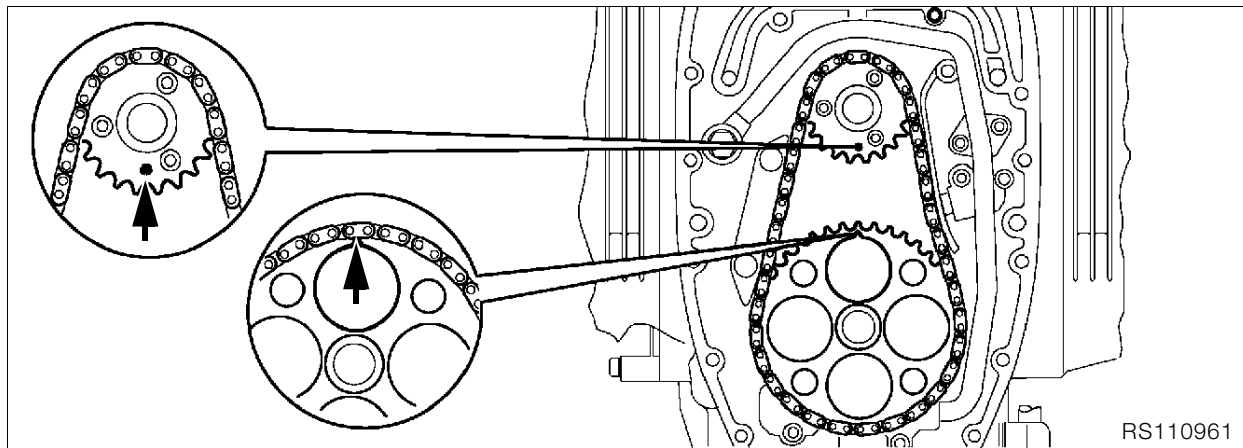

Right cylinder = at TDC on ignition stroke:
marks (arrows) on chainwheel/auxiliary shaft and
chain sprocket/crankshaft are aligned.

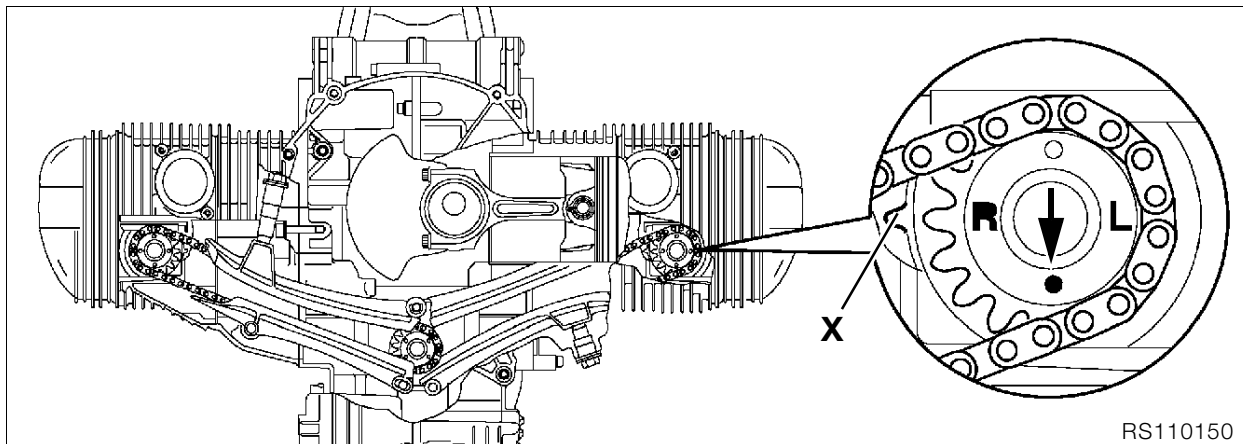

- Locate ignition-stroke TDC with insert pin, **BMW No. 11 2 650**, at hole in clutch housing and engine block.



Note:

With the engine installed, adjust TDC with dial gauge holder, **BMW No. 00 2 650**, and dial gauge, **BMW No. 00 2 510**.

Right cylinder = at TDC on ignition stroke:
Locating pin (arrow) on right camshaft sprocket
points downwards.

Mark (**R** or **arrow**) and tip of tooth on right camshaft
sprocket is **precisely** aligned with mark **X** on timing
gear carrier.

- Check setting again with timing chain tensioner installed.

Installing left cylinder head

Adjustment specification



Caution:

When installing, **always** begin with the **right** cylinder.

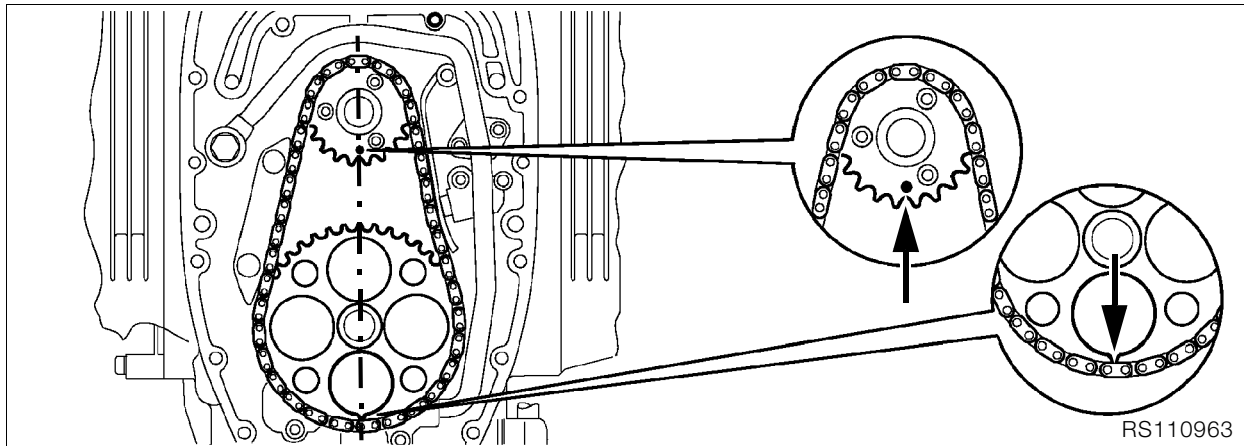

Left cylinder = TDC on ignition stroke: marks (arrows) on chain sprocket/auxiliary shaft and chain-wheel/crankshaft face down

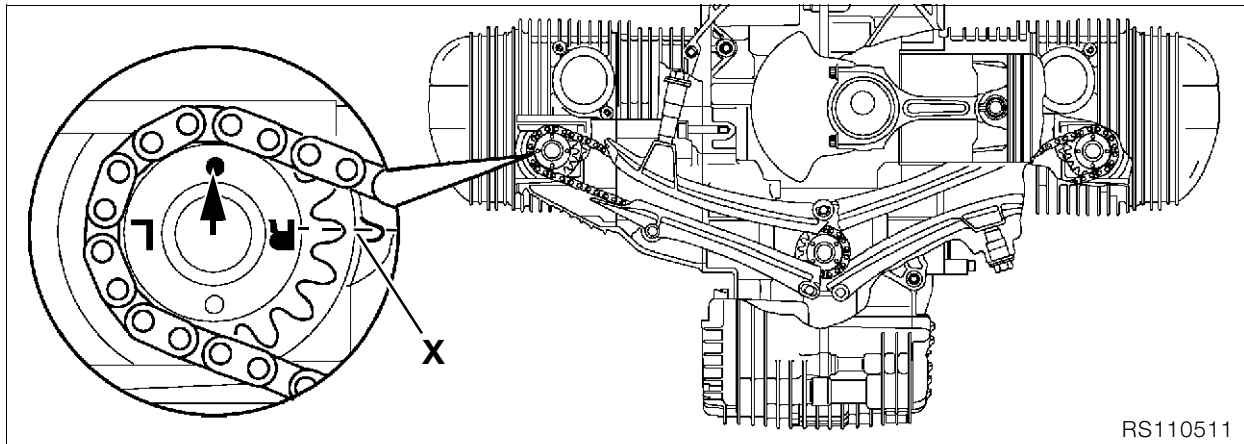

- Locate ignition-stroke TDC with insert pin, **BMW No. 11 2 650**, at hole in clutch housing and engine block.



Note:

With engine installed, adjust to TDC with dial gauge holder, **BMW No. 00 2 650**, and dial gauge, **BMW No. 00 2 510**.

Left cylinder = at TDC on ignition stroke:
Locating pin (arrow) on left camshaft sprocket points upwards.

Mark (**R** or **arrow**) and tip of tooth at left camshaft sprocket is aligned **precisely** with mark **X** on timing gear carrier.

- Check setting again with timing chain tensioner installed.

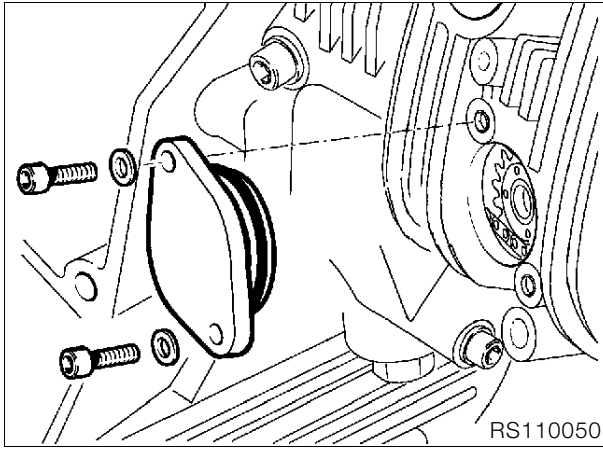

- Install the end cover with an O-ring which is in good condition.

Tightening torque:
 M 6 screw 9 Nm

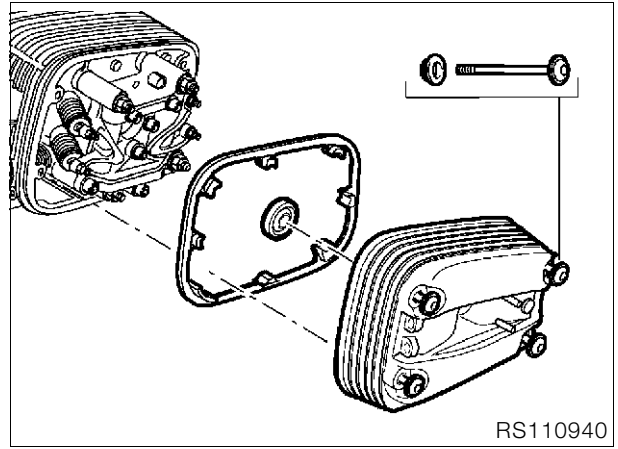

- Install cylinder head cover.

Caution:
 Ensure that gaskets are properly seated. Gaskets and sealing face must be free from oil and grease.

Tightening torque:
 Cover screw 8 Nm

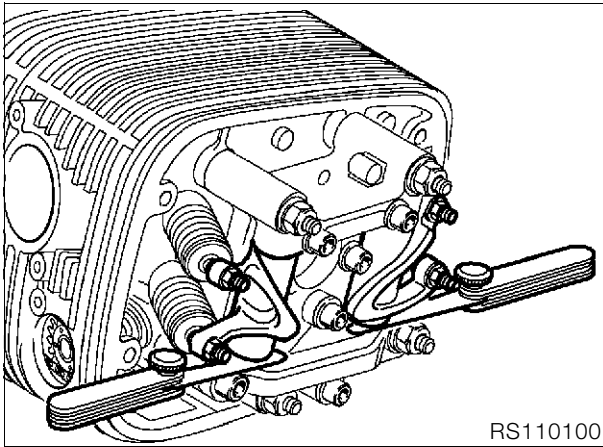

- If necessary, reduce end play to a minimum by repositioning the bearings.

Rocker end float:
 min. 0.05 mm (0.002 in)
 max. 0.40 mm (0.016 in)

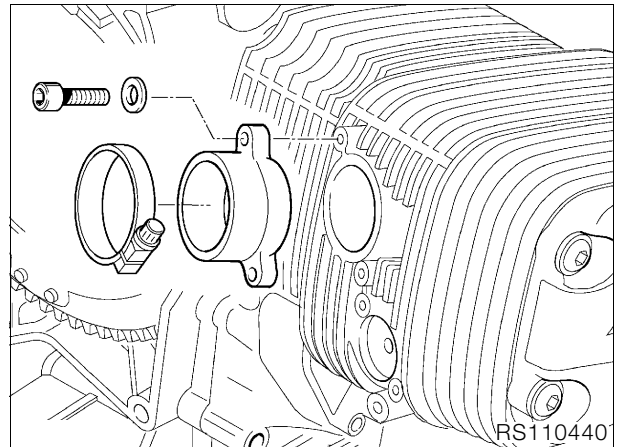

- Tighten air intake stub pipe.

Tightening torque:
 M 6 screw 9 Nm

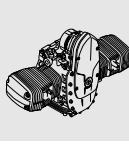

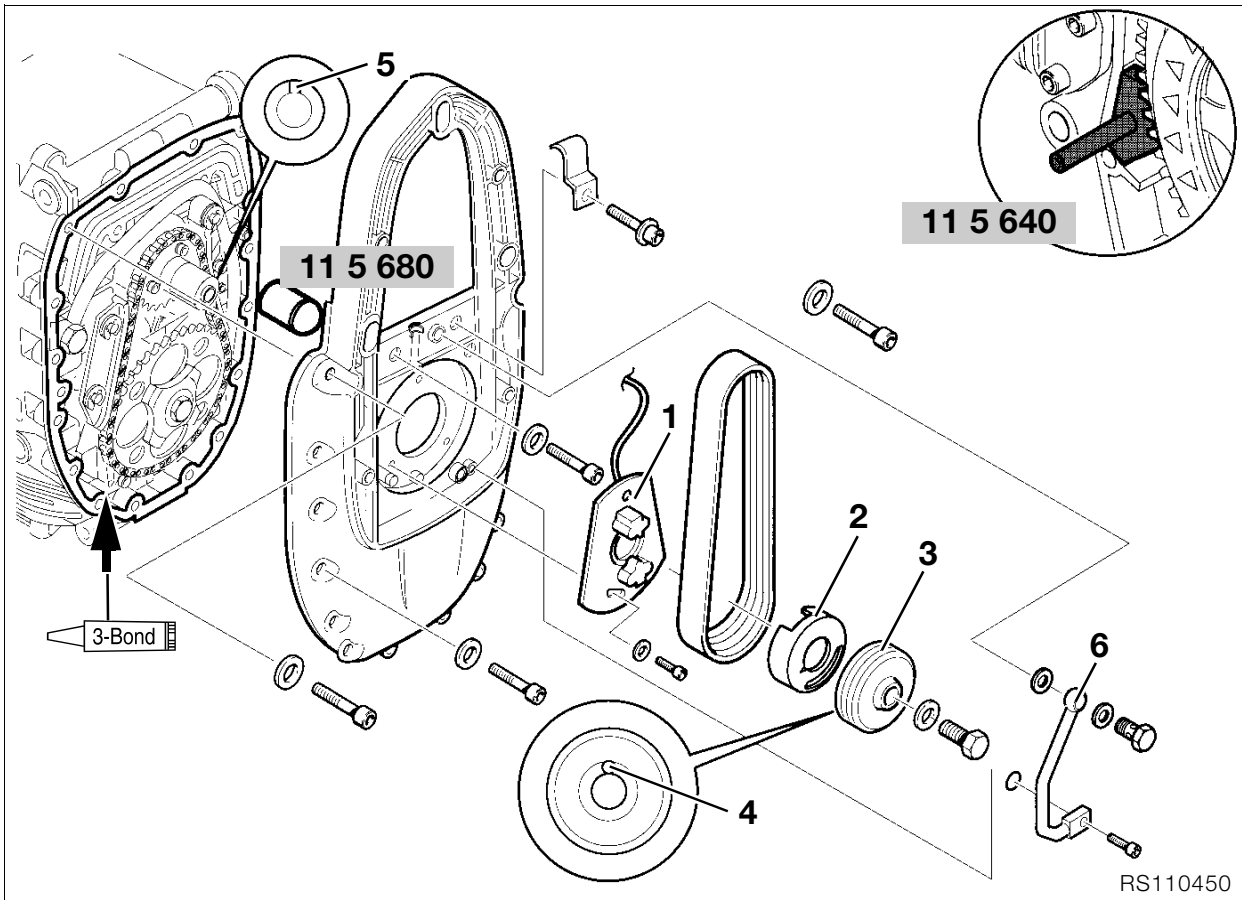

Installing alternator mount cover

- Place sliding sleeve, **BMW No. 11 5 680**, on crankshaft.
- Apply **3-Bond 1209** to the sealing face (arrow), which must be clean and free from grease.
- Install alternator mount cover.

Tightening torque:

M 8 screw	20 Nm
M 6 screw	9 Nm

- Install rotary breather pipe (6) with new sealing rings.

Tightening torque:

Vent line to alternator mount cover

M 8 screw	20 Nm
Banjo screw	25 Nm

Installing magnetic gate/belt pulley

- Install Hall-effect trigger plate (1).
- Lock clutch housing with special tool **BMW No. 11 5 640**.
- Secure rotor (2) of Hall-effect gate to the Poly-V belt pulley (3) with, for example, **Loctite instant adhesive**.
- Install the Poly-V belt pulley.

Caution:

Install retainer for Hall-effect gate rotor (4) at groove in crankshaft (5).

Tightening torque:

Retaining screw for belt pulley.....	50 Nm
--------------------------------------	-------

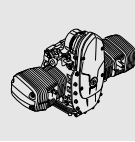
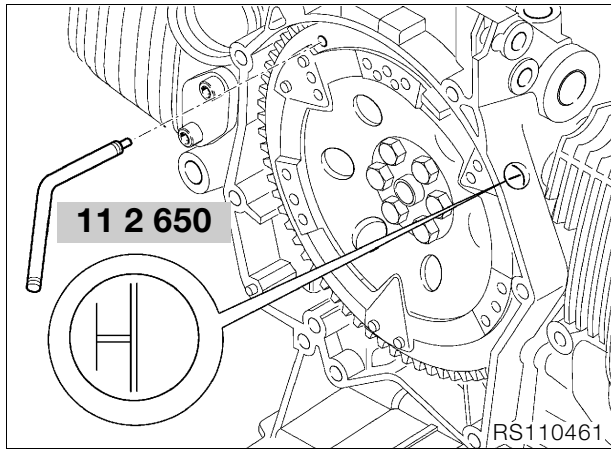

Timing the ignition

- Using TDC locating pin, **BMW No. 11 2 650**, lock the clutch housing.
- Connect **BMW MoDiTeC** with adapter cable to Hall-effect gate plate.
- Adjust in accordance with tester guidance.
- Remove the TDC locating pin.

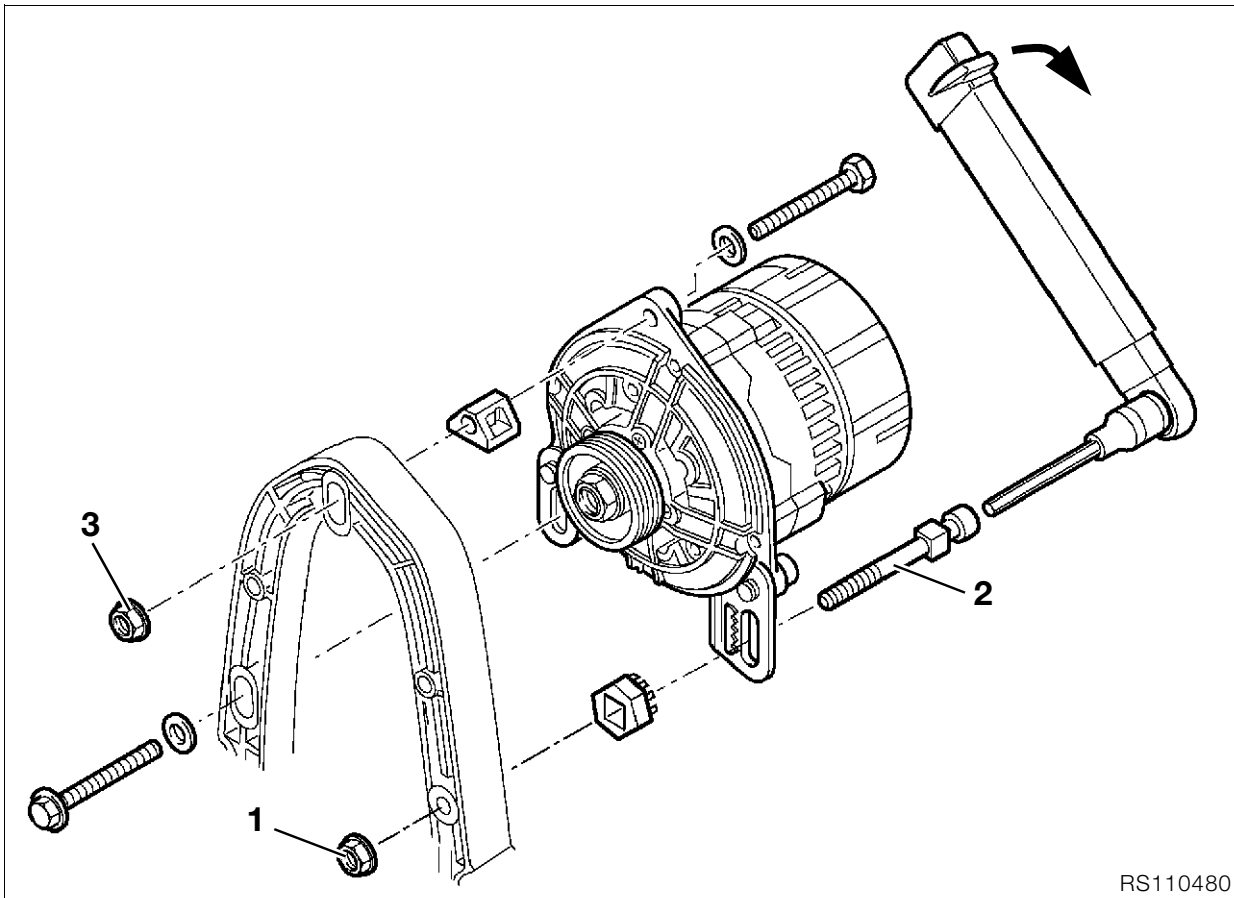

Installing alternator

- Install alternator.

Poly-V belt adjusting procedure:

Poly-V belt installation procedure:

- Screw hex nut (1) on adjusting screw (2) up handtight (**no tools to be used**)
- Tighten adjusting screw (2) with a torque wrench, fully tighten retaining nut (3), slacken adjusting screw and tighten screws fully.

Tightening torque:

Pre-tension Poly-V belt
with adjusting screw..... 8 Nm
Alternator to alternator support cover..... 20 Nm

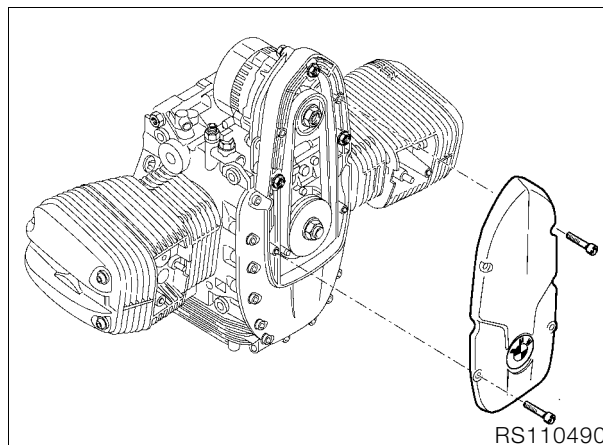

- Install front cover.

Installing engine

- Work in reverse order to that stated for removal.

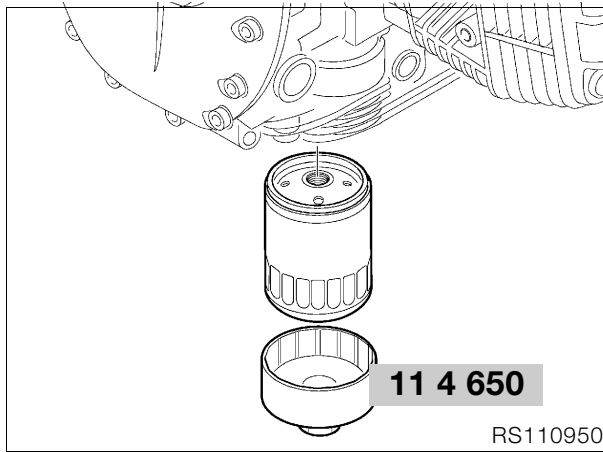

- Install oil filter with oil filter wrench, **BMW No. 11 4 650**.
- Insert and tighten oil drain plug with a new seal.

Tightening torque:

Oil filter (sealing face lightly oiled) 11 Nm
Oil drain plug 32 Nm

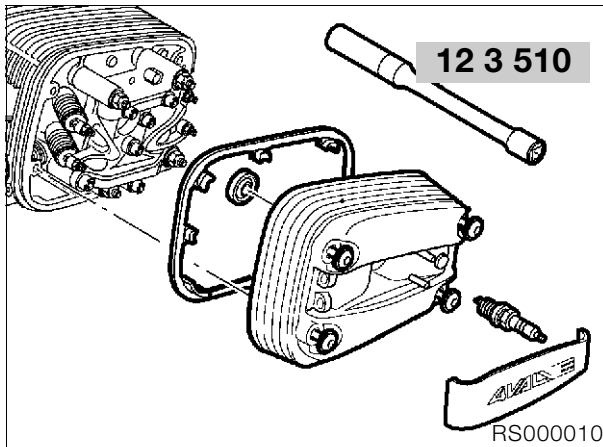

- Install spark plugs with spark plug socket wrench, **BMW No. 12 3 510**.

Tightening torque:

Spark plug 20 Nm

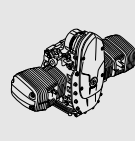

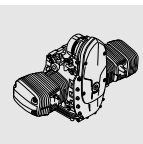

12 Engine electrics

Contents

Page

Technical data	3
Removing and installing coil and ignition lead	5
Check ignition coil resistance	5
Removing and installing alternator	6
Poly-V belt adjusting procedure:	6
Dismantling/reassembling alternator	7
Checking alternator	7
Checking armature for short to ground (earth)	7
Removing and installing starter motor	8
Dismantling/reassembling starter motor	9
Renewing carbon brushes	9
Checking starter motor	9
Checking starter relay	9
Removing and installing magnetic gate	10
Timing the ignition	11

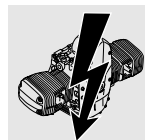

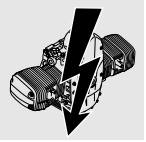

Technical data	R 850 C	R 1200 C
Starter motor		
Type	Permanent-magnet motor with planetary gear drive	
Gear ratios	Planetary gears 5.5 : 1	
Power rating	kW	1.1
Alternator		
Type	Three-phase alternating-current generator with integrated all-electronic voltage regulator	
Drive	Poly-V belt	
Gear ratios	1 : 1.5	
Maximum output rating	W/V	700/14
Maximum current at engine speed 4000 min ⁻¹	A	50
Nominal current at engine speed 1000 min ⁻¹	A	18
Max. operating speed	min ⁻¹	20 000
Spark plug		
Bosch	FR 6 DDC	
Electrode gap	mm (in)	0.8 (0.03)
Wear limit	mm (in)	1.0 (0.04)
Thread	metric	M 14 x 1.25
Ignition		
Ignition system	Motronic (mapped characteristic control)	
Ignition trigger	Two magnetic gates (Hall-effect transmitters) driven from crankshaft	
Ignition timing	°CS	0° ... + 43° before OT
Static ignition timing	°CS	Adjustment at TDC
Ignition coil		
Twin-spark coil		
Resistance: Primary between terminals 15 and 1	Ω	~0.5
Secondary between terminals 4a and 4b	kΩ	~7.5



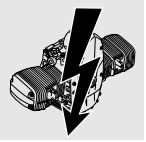

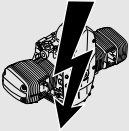
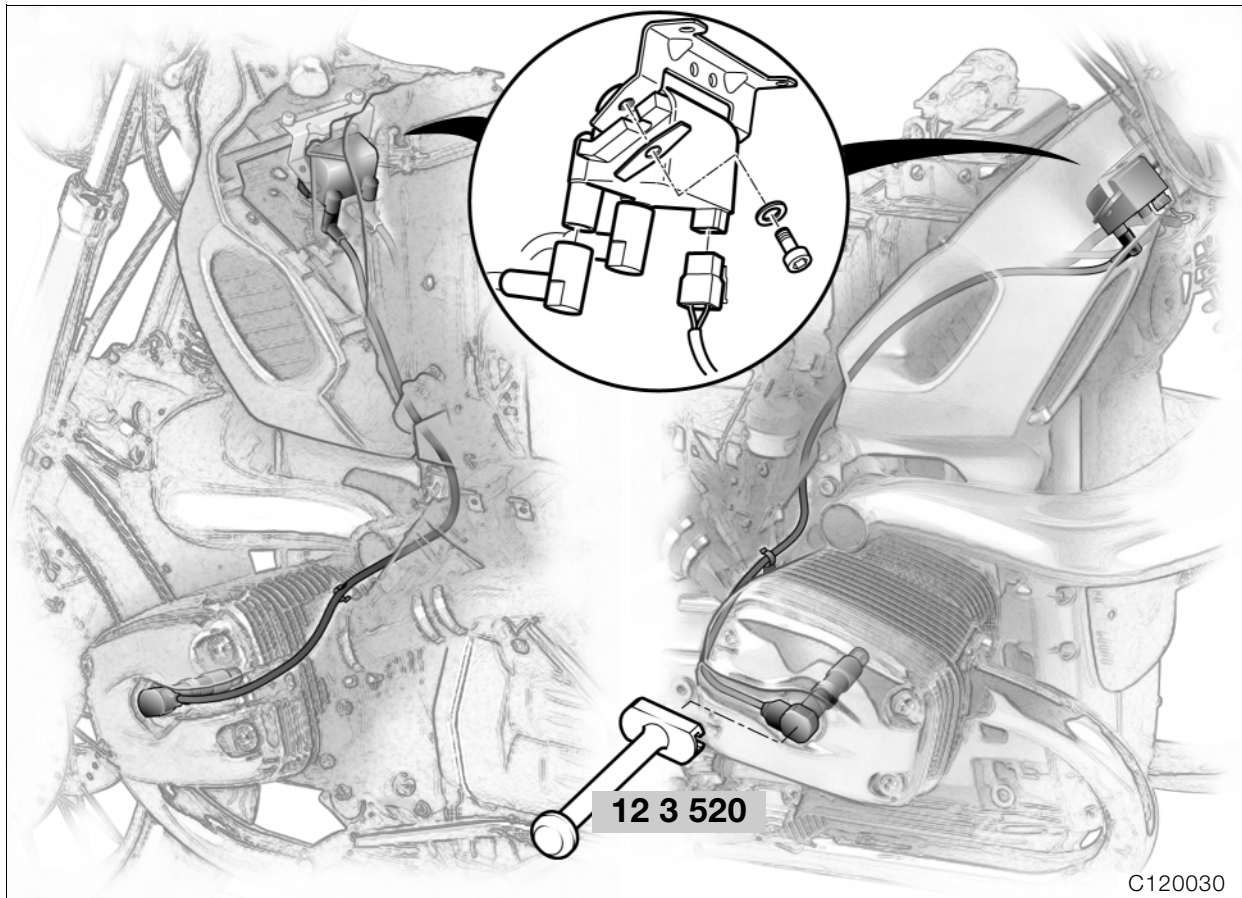

Removing and installing coil and ignition lead

- Remove fuel tank.



Caution:

Switch off ignition. Disconnect ground (earth) cable at battery and insulate it.

- Pull off spark plug cap with special puller, **BMW No. 12 3 520**.
- Release threaded connection for central electrical equipment box.
- Remove ignition leads.

Check ignition coil resistance

- Test with **BMW MoDiTeC**.

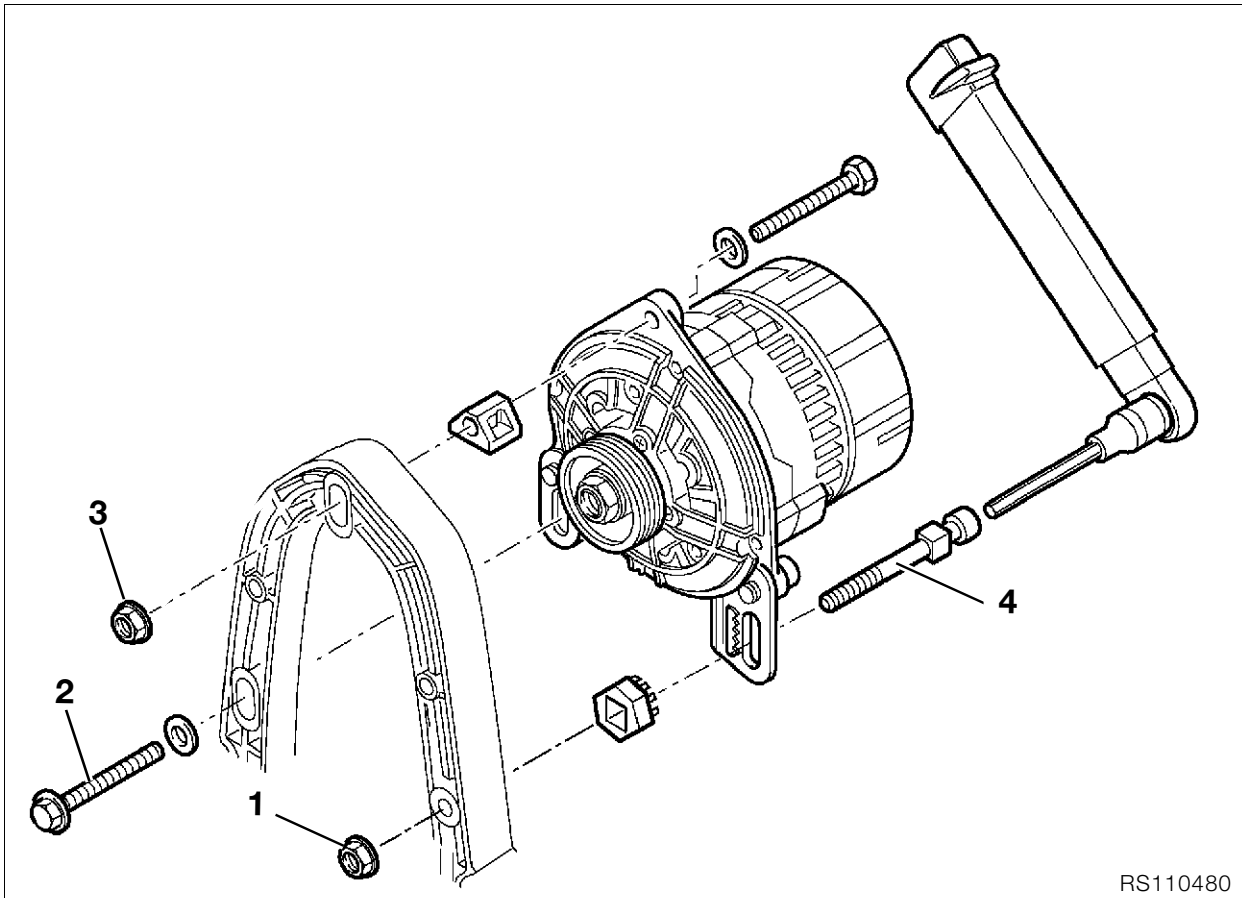

RS110480

Removing and installing alternator

- Remove seat.
- Remove fuel tank.

Caution:

Switch off ignition. Disconnect ground (earth) cable at battery and insulate it.

- Remove horn with holder.
- Remove front cover from engine.
- Remove alternator retainers (1, 2, 3).
- Remove rotary breather tube.
- Remove Poly-V belt.
- Remove the starter motor.
- Lock clutch housing with special tool **BMW No. 11 5 640**.
- Remove Poly-V belt pulley with rotor gate at crankshaft.
- Remove the left exhaust pipe.
- Drain engine oil.
- Remove the oil cooler return line.
- Pull the rear of the motorcycle down to the hoist platform and secure it with a strap or similar.
- Detach the left air intake flange.

Caution:

Mask off the leading link to prevent it from being scratched.

- Release the threaded connection for the lower suspension strut mount.
- Release the leading link shaft at the right and remove it to the left.
- Pull the leading link forwards.

- Place sliding sleeve, **BMW No. 11 5 680**, on the crankshaft and remove the alternator support cover.
- Detach the central electrical equipment box and raise it as far as possible.
- Detach the connecting leads at the alternator.
- Remove the alternator.
- Install by following the above work instructions in the reverse order.

Poly-V belt adjusting procedure:

Poly-V belt installation procedure:

- Place the Poly-V belt in position, tension it and turn the engine over once, then release belt tension.

Poly-V belt tensioning procedure:

- Loosen alternator mount (1, 2, 3).
- Screw up hex nut (1) at adjusting screw (4) lightly by hand (**using no tools**).
- Tighten adjusting screw (4) using torque wrench; fully tighten retaining nut (3), slacken off adjusting screw and tighten down screws.



Note:

See also Service Information 12 020 95 (700).



Tightening torque:

Poly-V belt preload.....	8 Nm
Alternator to alternator support cover.....	20 Nm
Positive lead to alternator.....	15 Nm
Belt pulley at alternator	50 Nm

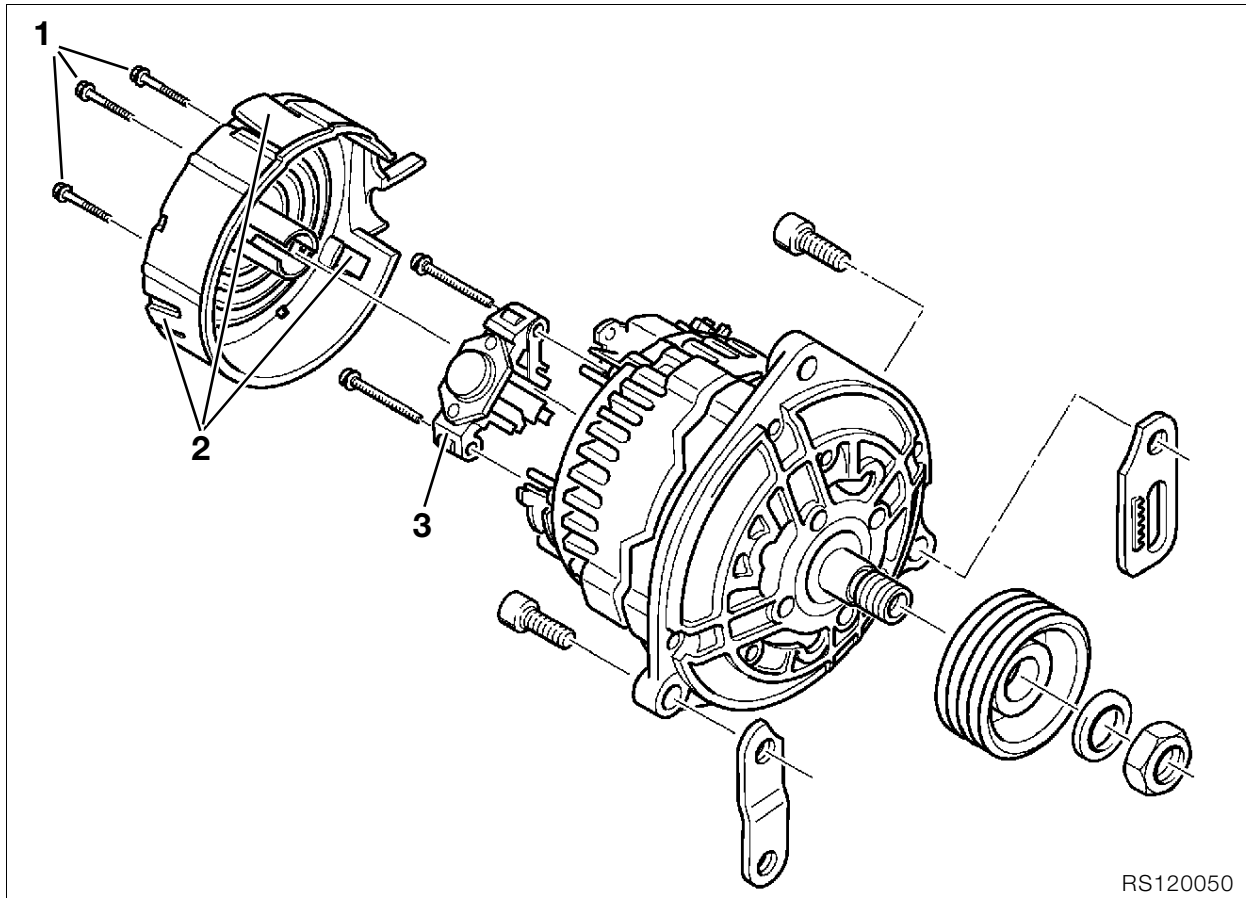

RS120050

Dismantling/reassembling alternator

- Take out the cover retaining screws (1).
- Release clips (2) and remove the cover.
- Remove voltage regulator (3).
- Remove the Poly-V belt pulley.
- Install by following the above work instructions in the reverse order.

 **Tightening torque:**

Belt pulley at alternator..... 50 Nm

Checking alternator

- Test with **BMW MoDiTeC**.

Checking armature for short to ground (earth)

- Test with **BMW MoDiTeC**.

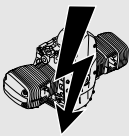

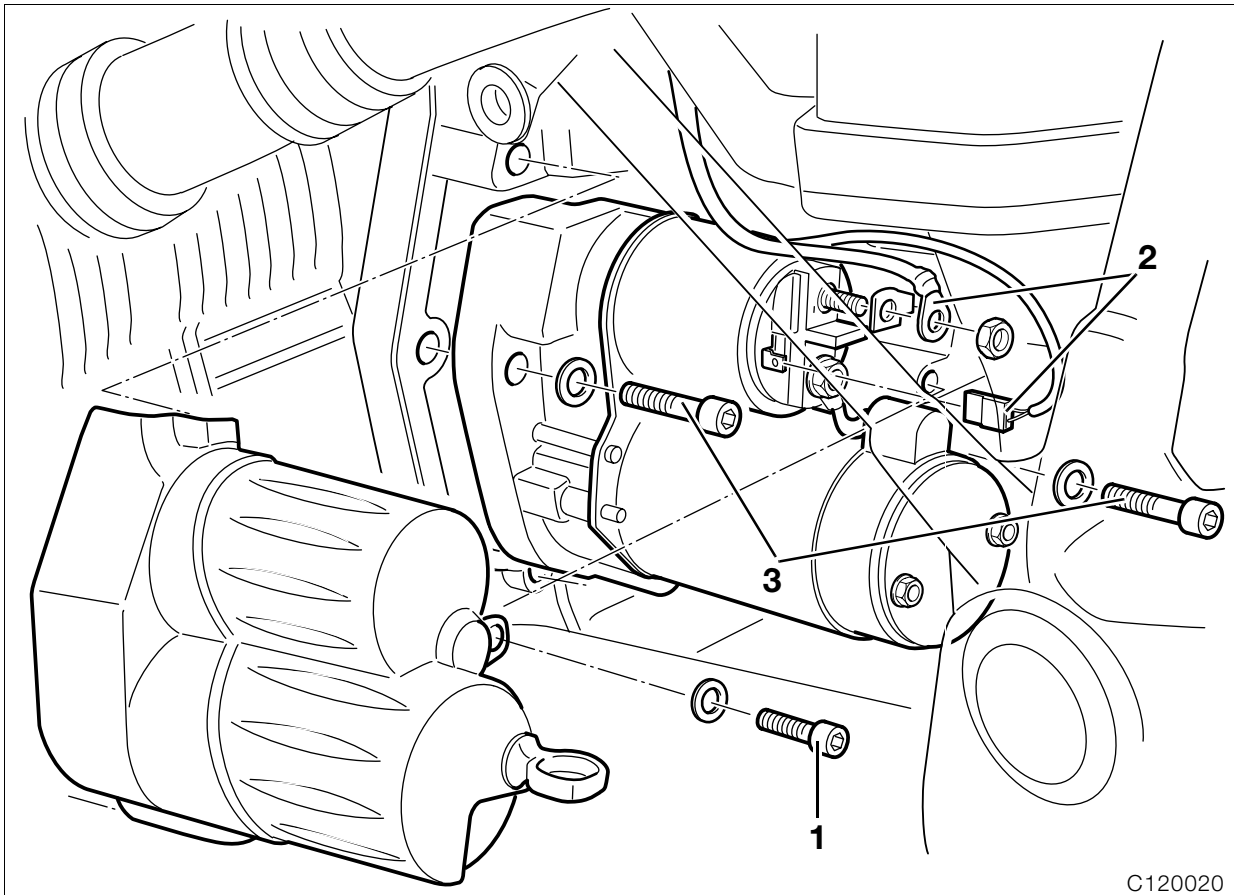

C120020

Removing and installing starter motor



Caution:

Disconnect earth (ground) lead from battery.
 Insulate earth (ground) lead.

- Release starter motor cover (1).
- Remove the cover.
- Detach lead (2).
- Release starter motor retainer (3).
- Remove the starter motor.
- Install by following the above work instructions in the reverse order.



Tightening torque:

Starter motor to engine 20 Nm
 Starter motor cover to gearbox housing 7 Nm
 Positive lead to starter motor 10 Nm

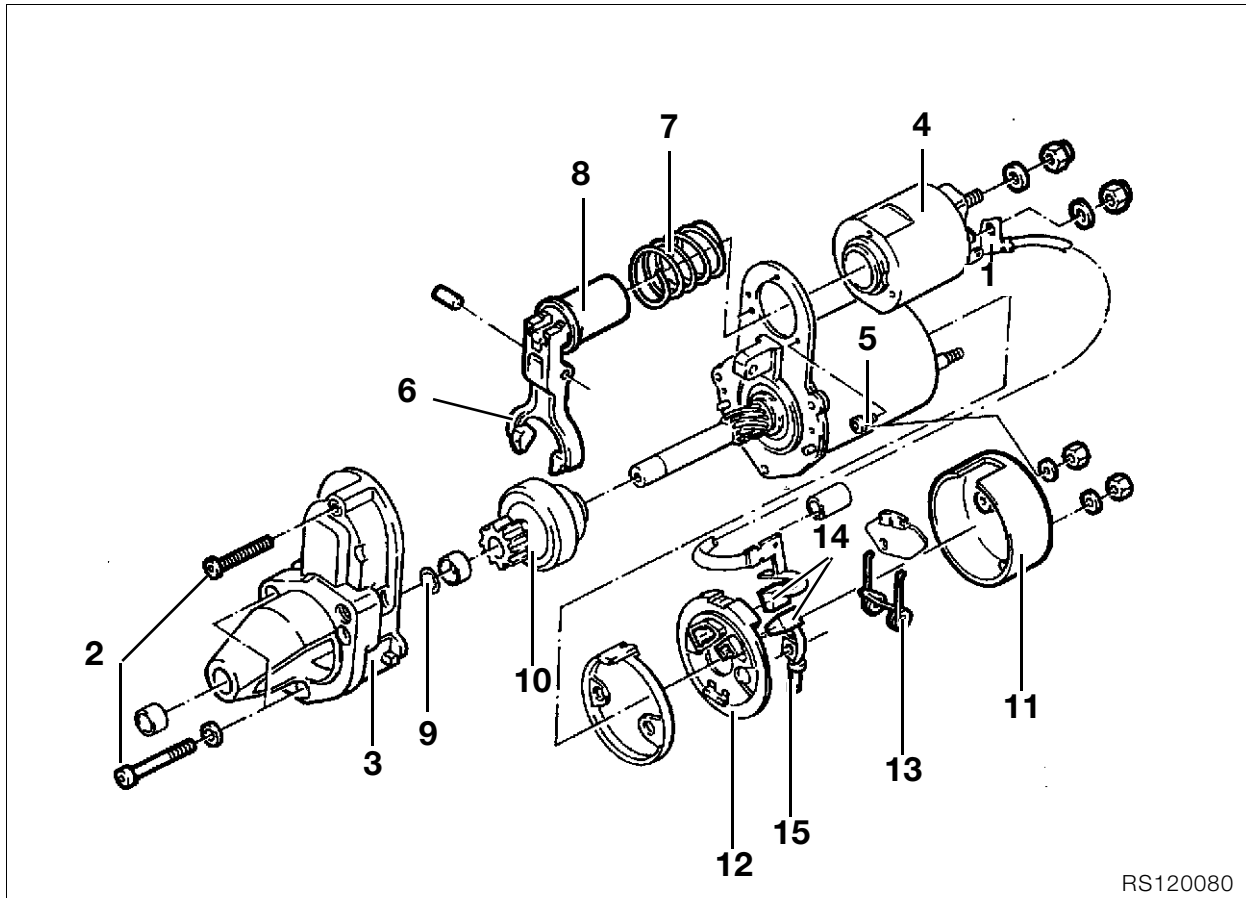

RS120080

Dismantling/reassembling starter motor

- Detach lead (1).
- Remove retaining screws (2).
- Remove flange (3).
- Remove solenoid switch (4) after taking out the retaining screws (5).
- Remove release lever (6) and spring (7) from solenoid switch (8).
- Remove retaining ring (9) and take starter motor gear assembly (10) off shaft.
- Install by following the above work instructions in the reverse order.
- Coat the helical thread and pull-in ring with grease.

Lubricant:..... Bosch PZ 2 V 3 silicone grease or equivalent

Renewing carbon brushes

- Detach lead (1).
- Remove cover (11).
- Remove holder (12) for carbon brushes.
- Lift up retaining springs (13) and remove carbon brushes (14).
- Install carbon brushes with retaining plate.
- Slide short lead (15) on to threaded pin.
- Install cover (11).
- Attach lead (1).

Checking starter motor

- Test with **MoDiTeC**.

Checking starter relay

- Test with **MoDiTeC**.

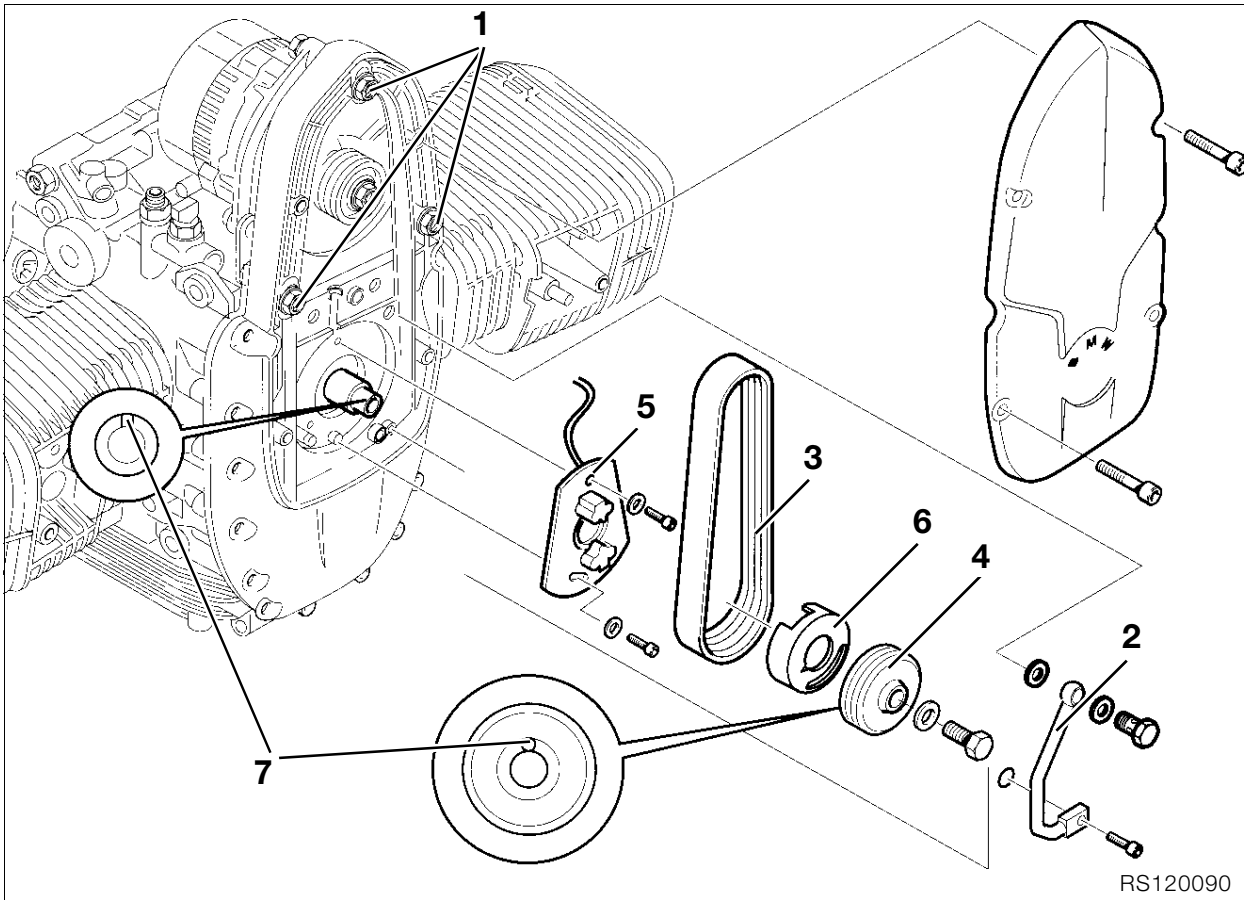

RS120090

Removing and installing magnetic gate

- Remove seat.
- Unscrew fuel tank mount.
- Pull fuel tank to the rear and support it at the front with a piece of wood or similar.

⚠ Caution:

Avoid scratching any components, for instance by inserting a piece of cloth between the fuel tank and the frame.

- Remove the horn with its holder.
- Remove front cover from engine.
- Unscrew alternator mount (1).
- Remove rotary breather tube (2).
- Remove Poly-V belt (3).

⚠ Caution:

Disconnect ground (earth) lead from battery. Insulate the ground (earth) lead!

- Remove the starter motor.
- Lock clutch housing with special tool **BMW No. 11 5 640**.
- Remove Poly-V belt pulley (4) with rotor gate at crankshaft.
- Separate the plug connection for the magnetic trigger in the central electrical equipment box.

📌 Note:

If necessary, mark position of magnetic trigger for later installation.

- Remove magnetic trigger (5).
- Install in reverse order of work.
- Attach rotor (6) of Hall-effect gate with adhesive to the Poly-V belt pulley (4).

Adhesive:Loctite instant adhesive or equivalent

⚠ Caution:

Install retainer for Hall-effect rotor at groove/crankshaft (7).

Carefully dismantle magnetic trigger lead. Tension Poly-V belt according to installation procedure.

🔧 Tightening torque:

Pre-tension of Poly-V belt 8 Nm
 Alternator to alternator mount cover..... 20 Nm
 Belt pulley to crankshaft..... 50 Nm

Timing the ignition



- Screw dial gauge holder, **BMW No. 00 2 650**, and dial gauge, **BMW No. 00 2 510**, into right or left spark plug hole.
- Turn the engine over until the piston is at TDC.
- Set the dial gauge pointer to zero.
- Check the dial gauge reading.
- Turn the engine over until the piston is at TDC.
- The dial gauge pointer must be at zero.
- Connect **BMW MoDiTeC** with adapter lead to the Hall-effect gate plate.
- Adjust as stated in the tester guide.

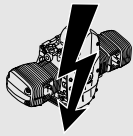

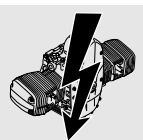

13 Fuel preparation and control

Contents

Page

Technical data	3
Removing and installing air cleaner	5
Removing and installing throttle stub pipe	5
Removing and installing throttle potentiometer	5
Removing and installing throttle positioner	6
Removing and installing throttle potentiometer	6
Removing and installing injectors	6
Removing and installing Motronic control unit	7

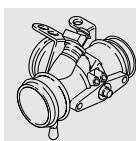

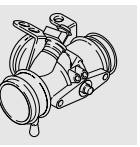

Technical data	R 850 C	R 1200 C
Fuel grade	Super (premium), unleaded, 95 octane (RON)	
Mixture preparation	Motronic MA 2.4	
Throttle stub pipe intl. dia.	mm (in)	35 (1.38)
Throttle angle in rest position	depending on throttle positioner	
Air cleaner	Flat-pattern paper element	

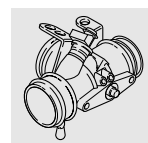

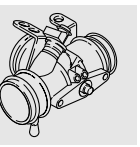

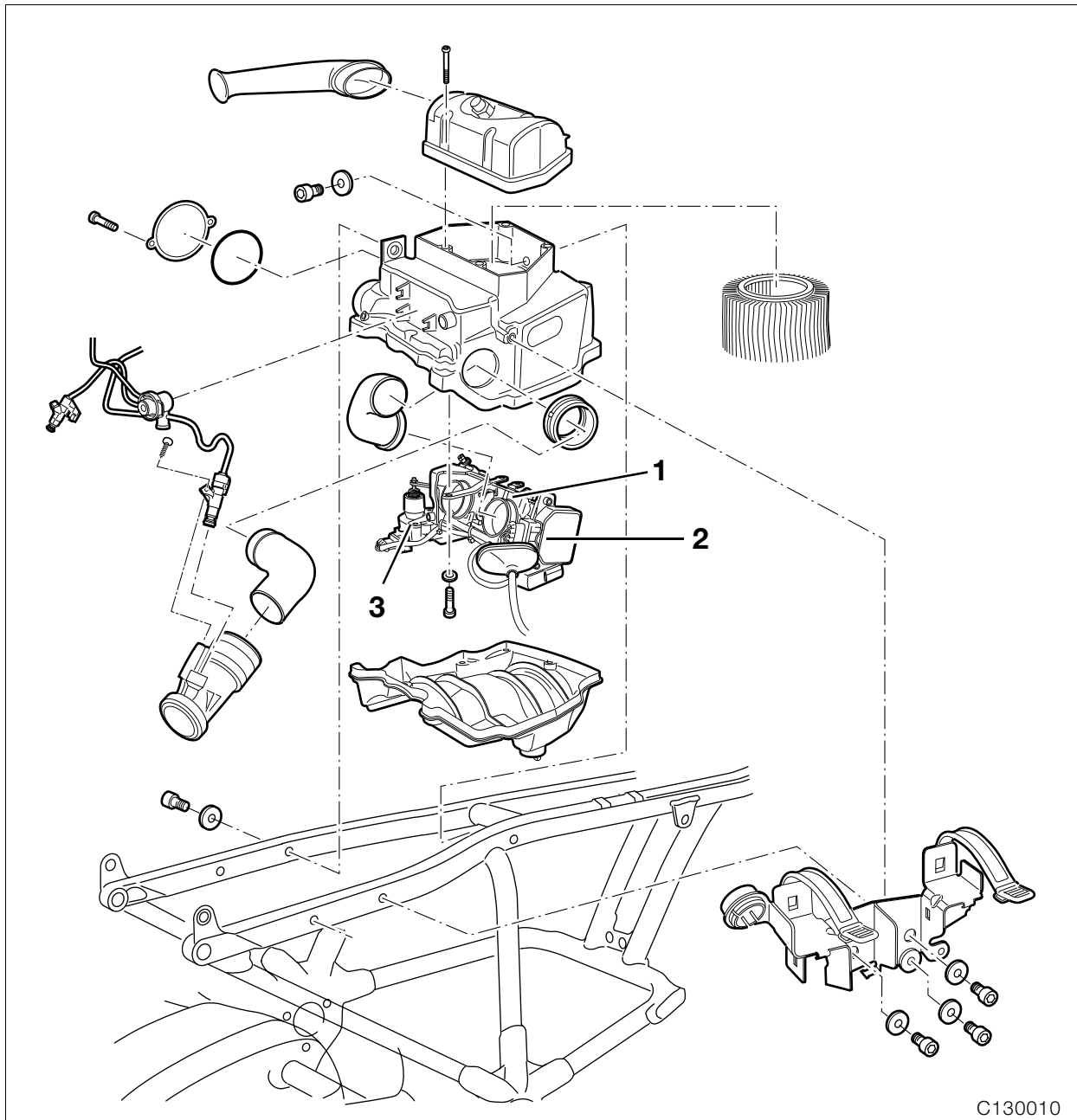

C130010

Removing and installing air cleaner

➔ See Group 46 (Removing/installing rear frame)

Removing and installing throttle stub pipe

- Remove throttle stub pipe (1).

Removing and installing throttle potentiometer

- Remove throttle potentiometer (2).
- Adjusting throttle potentiometer with **BMW MoDiTeC** after installing
- Mark screws with a paint spot.

Removing and installing throttle positioner

- Remove the throttle positioner (3).



Caution:

The throttle positioner operates at the control unit voltage of 5 V. It must not be connected directly to the motorcycle's electrical system.



Tightening torque:

Throttle positioner retaining screw
(clean thread + Loctite 2701)

Removing and installing throttle potentiometer

- When a new throttle potentiometer is installed, it must be adjusted in accordance with the **BMW MoDiTeC** reading.

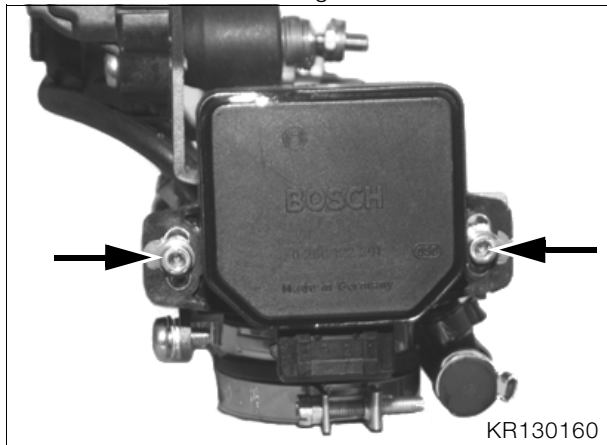
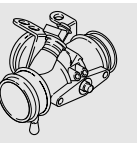

- Mark the retaining screws (arrows) with a paint spot.

Removing and installing injectors

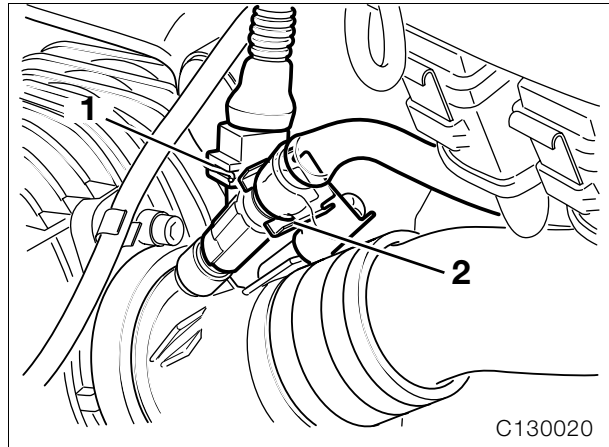

- Press in the spring catch at the injector plug (1) and pull off the plug.
- Unfasten retainer (2) for fuel pipe and pull off the pipe.
- Remove injector.
- Install by following the above work instructions in the reverse order.



Caution:

The keeper (2) must be inserted from the inside outwards. It then prevents the injector from turning. Make sure that the keeper (2) engages correctly. Make sure that O-rings at the injector are in good condition.

Removing and installing Motronic control unit

- Remove fuel tank.



Caution:

Switch off ignition; disconnect earth (ground) lead at battery and insulate it.

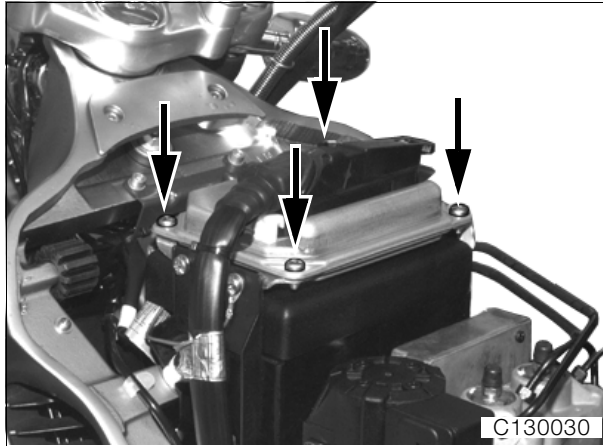

- Remove Motronic control unit.
- Remove connector strip.
- Install by following the above work instructions in the reverse order.

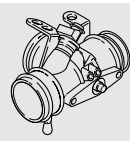

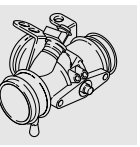

16 Fuel tank and lines

Contents

Page

Technical data	3
Removing and installing fuel tank	5
Removing and installing fuel filter, fuel pump and fuel level sensor	6
Removing and installing fuel filter	6
Removing and installing fuel pump and fuel level sensor	7
Checking fuel pump pressure	7
Removing and installing fuel distributor and pressure regulator	7





Technical data		R 850 C	R 1200 C
Fuel tank			
Tank capacity	l (Imp. gal/ US gal)	17 (3.74/4.50)	
including reserve of	l (Imp. gal/ US gal)	4 (0.88/1.06)	
Fuel pump			
Type		Gear-type	
Make		VDO	
Operating voltage	V	12	
Fuel pressure	bar (psi)	3±0.2 (42.69±2.85)	
Delivery volume	l/h (Imp.gal/h, US gal/h)	110 (24.21, 29.06)	





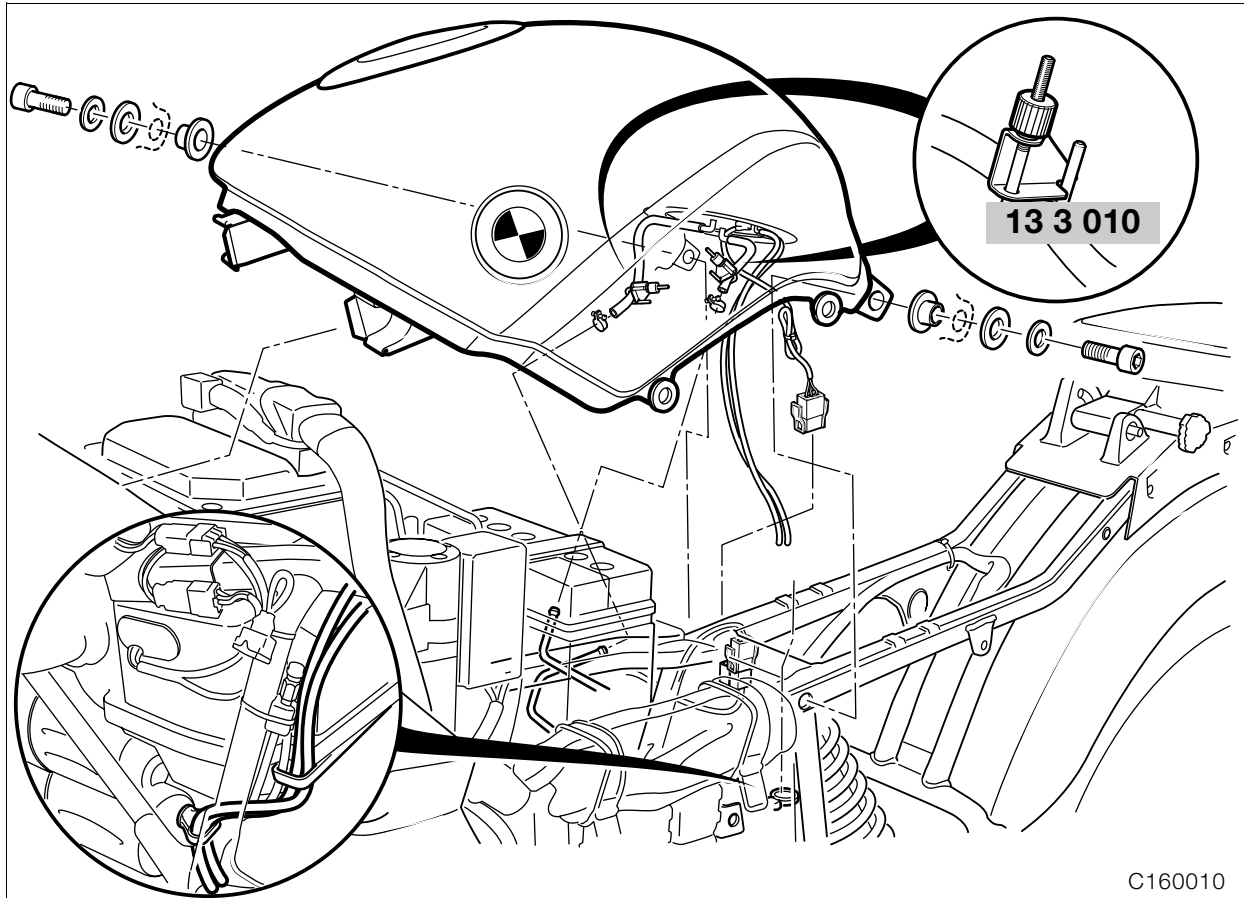

Removing and installing fuel tank

- Seal the fuel feed and return lines with a hose clip, **BMW No. 13 3 010**, detach and pull off.



Tightening torque:

Fuel tank to rear frame 22 Nm



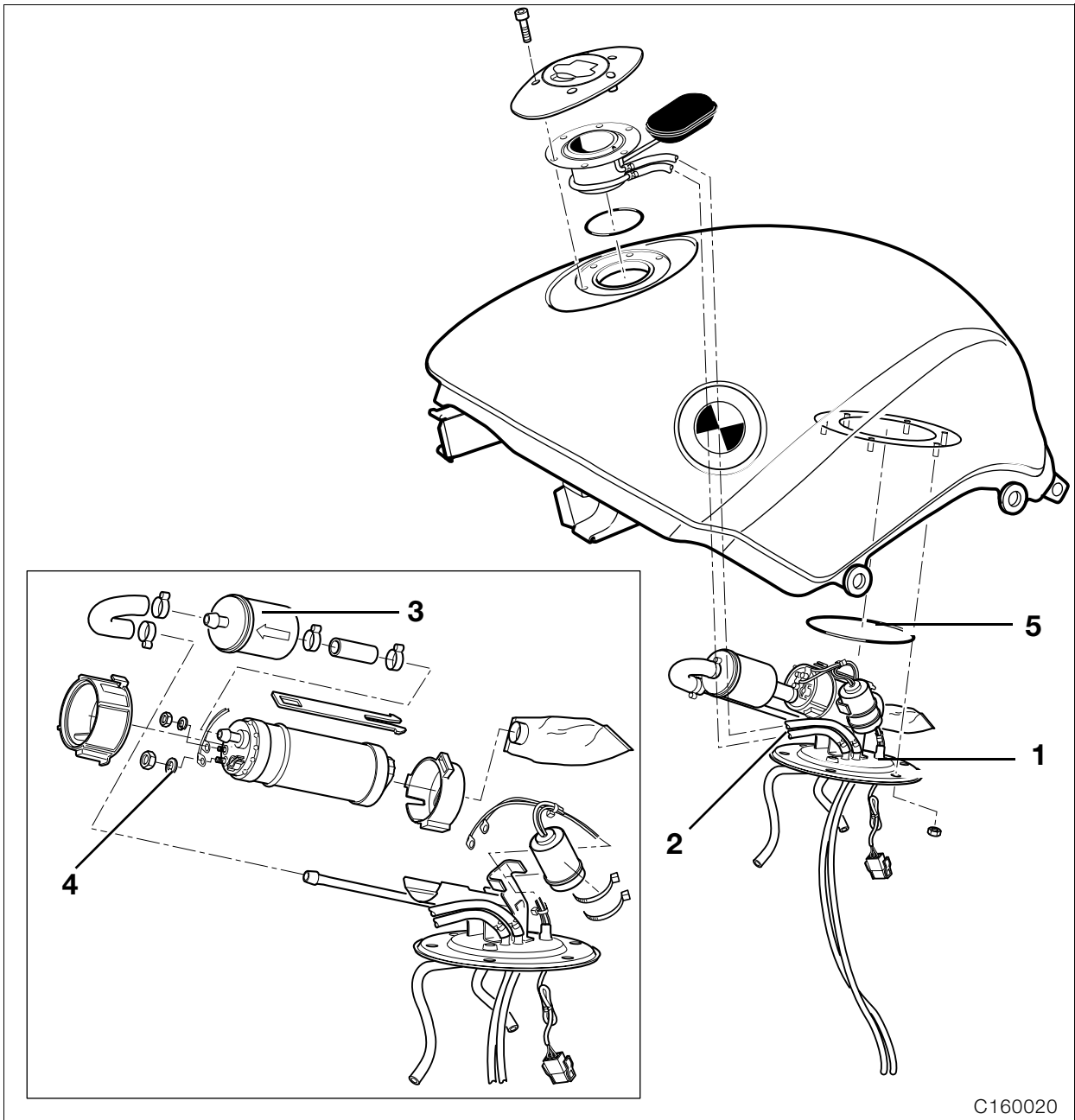

Removing and installing fuel filter, fuel pump and fuel level sensor

Caution:

Fuel is flammable and a hazard to health. Observe relevant safety regulations.

- Drain fuel tank.
- Remove fuel pump unit (1) and detach hoses (2).

Removing and installing fuel filter

- Release hose clips at fuel filter (3).

Caution:

Note direction of fuel flow at filter.

- Secure non-reusable hose clips with pliers, **BMW No. 13 1 500**.

Removing and installing fuel pump and fuel level sensor

- Detach the electrical connections at the fuel pump (4).
- Release the hose clip at the fuel pump.
- Remove fuel pump.
- Install by following the above work instructions in the reverse order.
- Secure non-reusable hose clips with pliers, **BMW No. 13 1 500**.



Caution:

Use only an O-ring (5) in good condition.
After installing, check fuel pump assembly for leaks.



Tightening torque:

Fuel pump assembly to tank..... 6 Nm

Checking fuel pump pressure

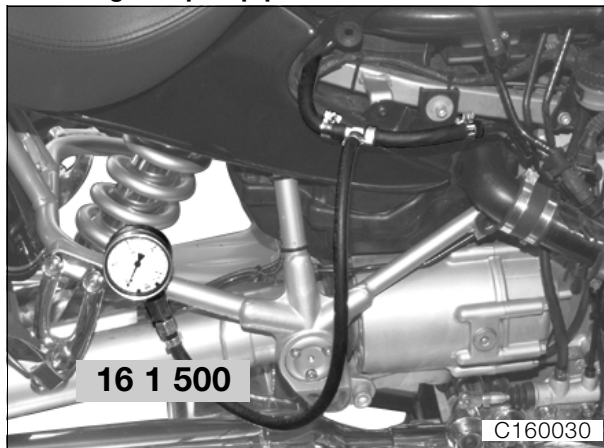

- Connect test pressure gauge, **BMW No. 16 1 500**, at the pressure side.
- Run engine at idle speed.

Fuel pressure:

Desired value 3 ± 0.2 bar (42.69 ± 2.85 psi)



Note:

If fuel pressure is low, check pump, fuel filter, pressure regulator and fuel line.

Removing and installing fuel distributor and pressure regulator

- Remove fuel tank.
- Remove the battery.
- **[ABS]** Remove the ABS unit.
- Remove the battery carrier.

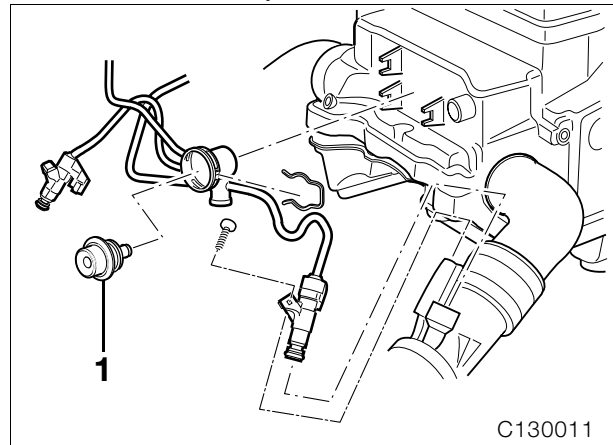

- Remove the fuel distributor with pressure regulator (1) from the holder.
- Install by following the above work instructions in the reverse order.
- **[ABS]** Bleed the brake system.





18 Exhaust system

Contents

Page

Removing and installing exhaust system	3
Removing and installing silencer (muffler)	3
Removing and installing front exhaust pipes	3

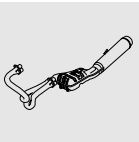

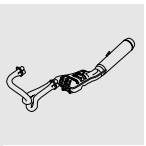

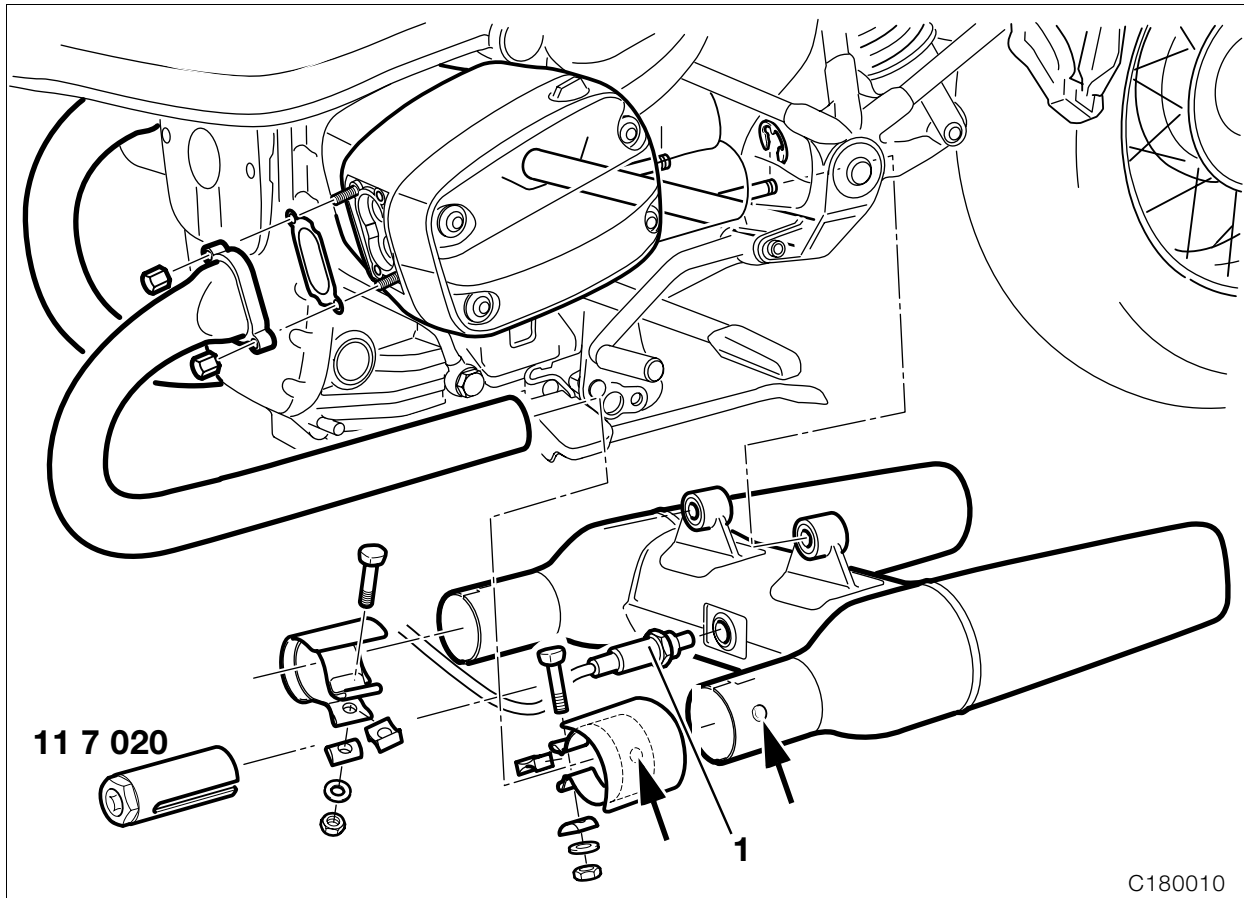

C180010

Removing and installing exhaust system

Removing and installing silencer (muffler)

- Unscrew fuel tank and pull to the rear.
- Separate the plug connection for the oxygen sensor and detach the wire.



Caution:

Do not pull the oxygen sensor cable.

- Loosen the retaining clips.
- Pull off the silencer (muffler).
- Install by following the above work instructions in the reverse order.
- When installing, align the hole (arrow) on the clip with the embossed dot (arrow) on the silencer (muffler).



Caution:

Note position of wiring for oxygen sensor.



Tightening torque:

Clip at silencer (muffler)
(apply Never Seez to the clip contact face)... 55 Nm

- Remove/install the oxygen sensor (1).

- Secure the oxygen sensor with special socket wrench insert, **BMW No.11 7 020**.



Caution:

After a trial run, read out Motronic fault memory.



Tightening torque:

Oxygen sensor
(coat thread with Never Seez)..... 45 Nm

Removing and installing front exhaust pipes

- When installing, align the hole (arrow) in the clip with the embossed dot (arrow) on the silencer (muffler).



Tightening torque:

Exhaust manifold to cylinder head..... 24 Nm
Clip at silencer (muffler)
(coat clip contact face with Never Seez)..... 55 Nm

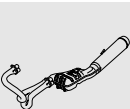

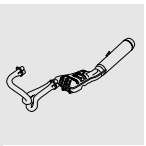

21 Clutch

Contents

Page

Technical data	3
Removing and installing clutch	5
Removing clutch	5
Installing clutch	5
Removing and installing clutch hydraulic line	6
Removing and installing clutch slave cylinder	6
Filling/bleeding clutch line	7

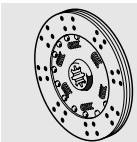

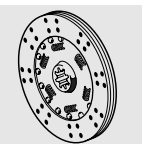

Technical data		R 850 C	R 1200 C
Type of clutch		single dry plate with increased-leverage diaphragm spring	
Operation		hydraulic, with master and slave cylinders	
Master cylinder piston Ø	mm (in)	13 (0.51)	
Slave cylinder piston Ø	mm (in)	24 (0.94)	
Clutch fluid		DOT 4 brake fluid	
Clutch plate dia.	mm (in)	165 (6.50)	
Wear dimension	mm (in)	4.6 (0.18) (measured on rivets of clutch plate using tips of sliding caliper, pressed together by hand)	





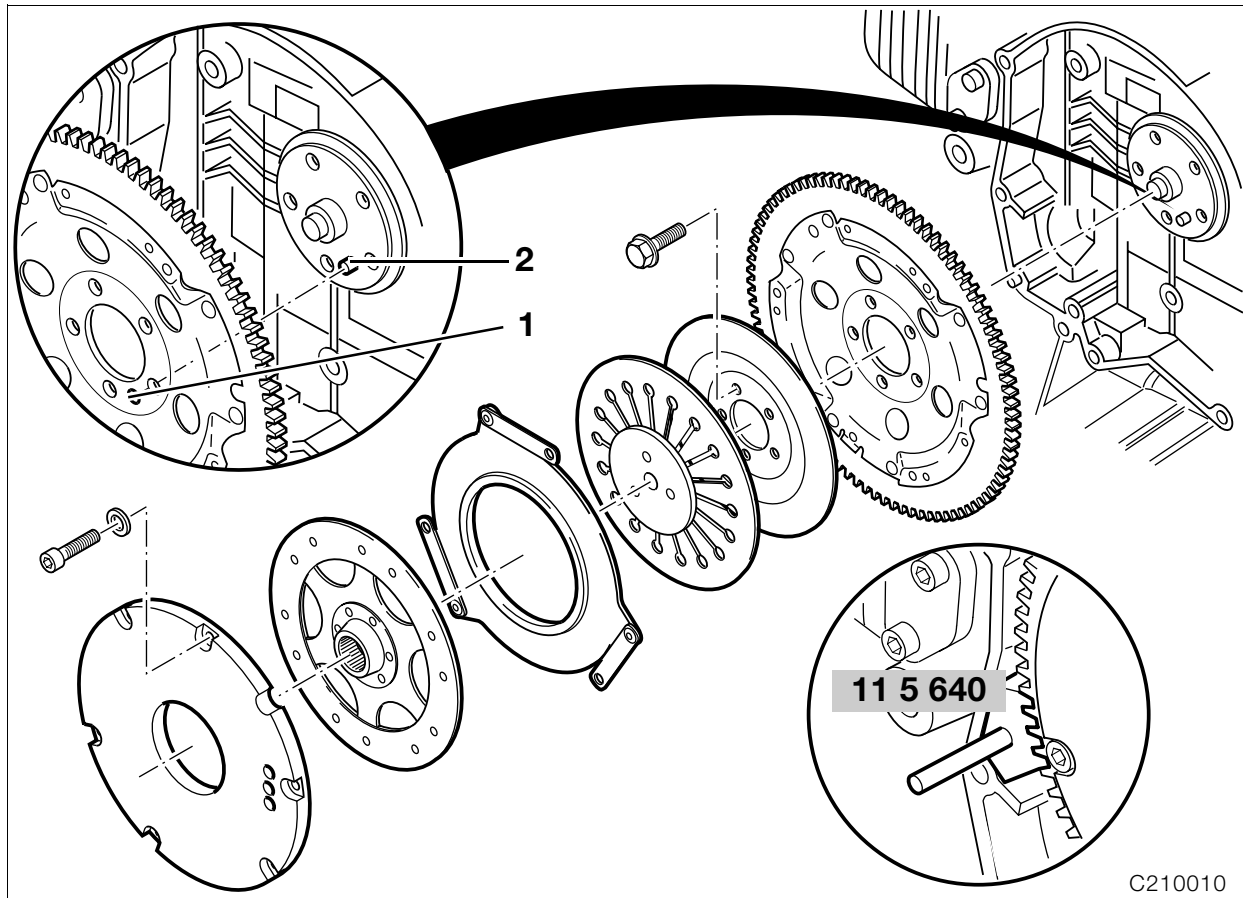

Removing and installing clutch

Removing clutch

- ➔ Preparatory work is as for “Removing gearbox” (see Group 23)
- Lock the clutch housing with special tool **BMW No. 11 5 640**.
- Remove the clutch.

Installing clutch

- Install clutch housing with mark (1) aligned with crankshaft mark (2).
- Lock the clutch housing with special tool **BMW No. 11 5 640**.



Caution:

Always use new bolts for housing and cover.

- Insert all screws by hand and tighten down.



Tightening torque:

Clutch housing to crankshaft
(oil screw threads lightly)

Initial tightening 40 Nm
Wrench angle 32°

- Install clutch.



Caution:

Offset the color marks on the clutch housing, driven plate and housing cover through 120° in each case.

- Secure the clutch with the retaining screws.
- Center the clutch plate with centering pin, **BMW No. 21 2 673**.
- Tighten retaining screws alternately in a cross-wise pattern.

Lubrication points:

Splines on clutch plate and gearbox input shaft.
Diaphragm spring contact surface on clutch housing.
Diaphragm spring contact surface on pressure plate.

..... Optimoly MP3 paste



Tightening torque:

Housing cover to flywheel 12 Nm

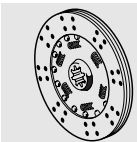

C210010

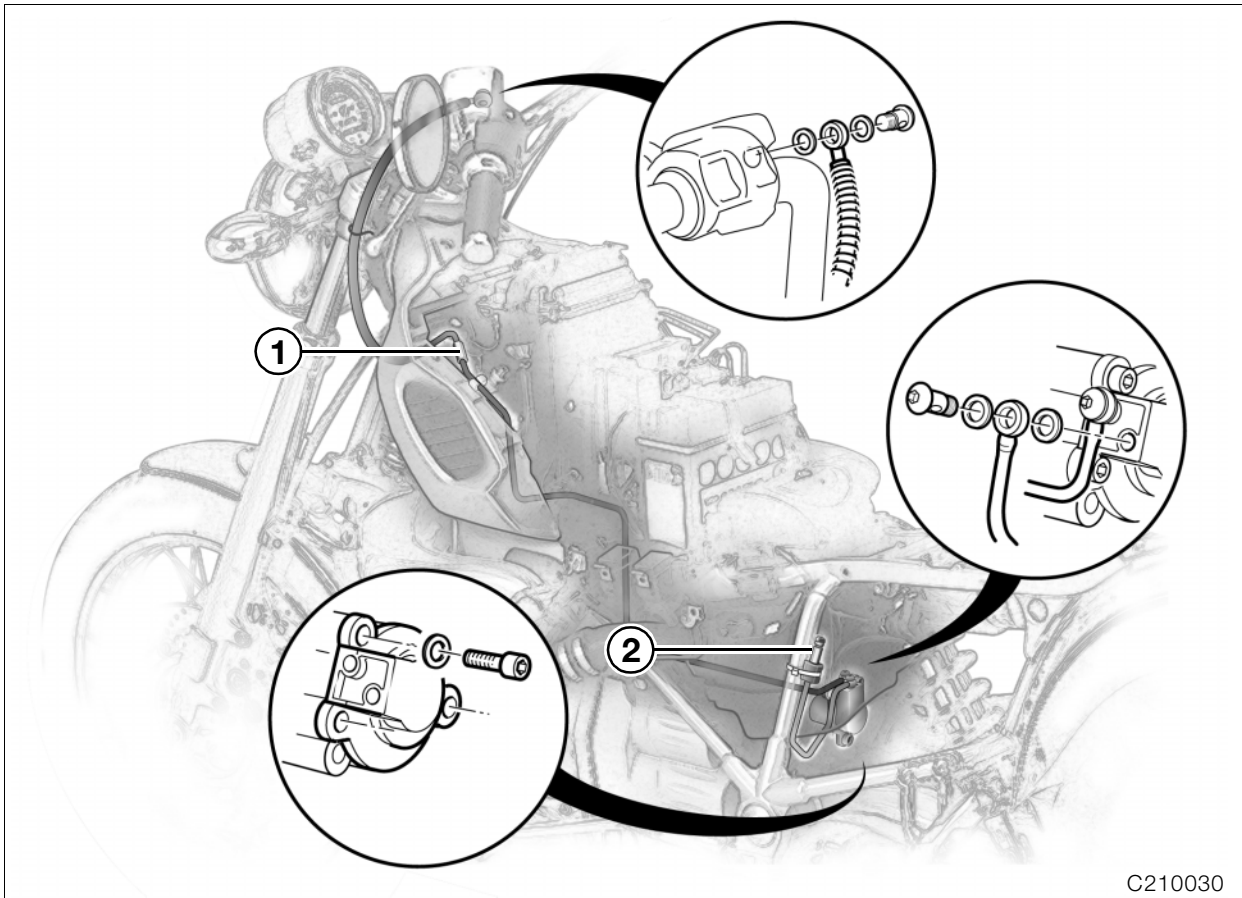

C210030

Removing and installing clutch hydraulic line

- Remove fuel tank.
- Remove the battery.
- [ABS] Drain the brake system.

Caution:

Do not allow brake fluid to come into contact with painted parts of the motorcycle, because brake fluid destroys paint.

- [ABS] Remove the ABS unit.
- Remove battery carrier.
- Drain the clutch operating system.

Caution:

Do not allow brake fluid to come into contact with painted parts of the motorcycle, because brake fluid destroys paint.

- Detach the clutch line at the separating point (1).
- Detach the clutch slave cylinder and pull it to the rear with the line.
- Detach the lines at the clutch slave cylinder.
- Install by following the above work instructions in the reverse order.
- Fill the clutch operating system.
- [ABS] Add fluid to brake system.

Note:

When installing, fit new sealing rings.

Tightening torque:

Clutch line to handlebar fitting 18 Nm

Removing and installing clutch slave cylinder

- Remove fuel tank.

Caution:

Do not allow brake fluid to come into contact with painted parts of the motorcycle, because brake fluid destroys paint.

- Detach clutch line at separating point (1).
- Detach and raise the central electrical equipment box at the left.
- Detach the clutch slave cylinder and pull it to the rear with the line.
- Detach lines at clutch slave cylinder.
- Remove clutch slave cylinder.
- Install by following the above work instructions in the reverse order.
- Fill the clutch operating system.

Note:

When installing, fit new sealing rings.

Tightening torque:

Clutch slave cylinder to gearbox 9 Nm

Filling/bleeding clutch line



Caution:

Do not allow brake fluid to come into contact with painted parts of the motorcycle, because brake fluid destroys paint.



Note:

The description applies to a brake system filling and bleeding device with vacuum extraction of brake fluid at the bleed line.

If other devices are used, comply with their manufacturers' instructions.

- Take off reservoir cover with rubber diaphragm.
- [Standard handlebar/Police] Raise motorcycle on auxiliary stand, **BMW No. 00 1 560**, and swing handlebar fully to right.
- [Optional handlebar/Easy Rider] Prop motorcycle on side stand and turn handlebar fully to right.

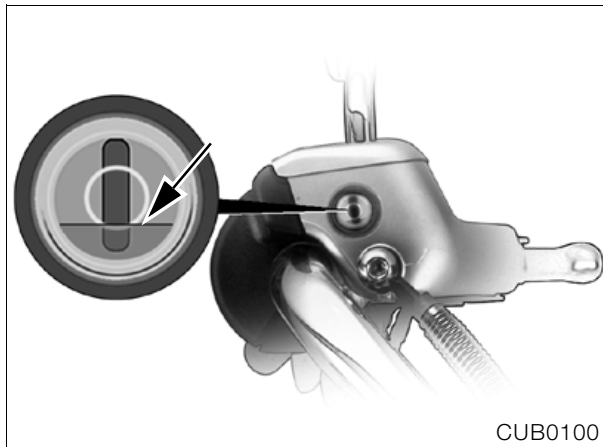

Caution:

With the clutch lining in new condition the surface of the fluid (arrow) must be up to the lower edge of the ring mark; it must **not be below** normal.



Note:

As the clutch lining wears, the fluid level in the reservoir rises.

- Top up the brake fluid.
- Bleed the clutch line through bleed screw (2).



Caution:

During the bleeding operation the brake fluid must not drop below the MIN mark or else air will be drawn into the clutch operating system. If this occurs, repeat the bleeding operation.

- Continue to draw off/pump through the brake fluid until it is clear and free from bubbles.
- Close the bleed screw.
- Correct the fluid level.

- Replace the reservoir lid with rubber diaphragm in position.
- Tighten the reservoir cover without using force.

Operating materials

Brake fluidDOT 4

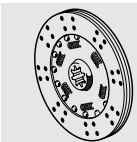

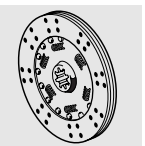

23 Gearbox

Contents

Page

Technical data	3
Removing and installing gear pedal	5
Removing gearbox	5
Renewing the shaft sealing rings in the gearbox housing and gearbox cover	7
Renew the input shaft sealing ring at the input end	7
Renewing output shaft sealing ring	7
Renewing input shaft sealing ring at output side	8
Renewing shaft sealing ring for selector drum	8
Renewing sealing ring for selector shaft	8
Dismantling gearbox	9
Removing gearbox housing	9
Removing selector drum	10
Dismantling/assembling selector shaft	10
Removing gearbox shafts	11
Renewing deep-groove ball bearing on intermediate shaft	11
Dismantling/assembling input shaft	12
Dismantling input shaft	12
Assembling input shaft	13
Dismantling/reassembling output shaft	14
Stripping down output shaft	14
Assembling output shaft	15
Checking endplay	16
Checking/adjusting fully compressed length of gearbox shafts, selector drum	17
Checking/adjusting fully-compressed length of intermediate shaft	17
Checking/adjusting fully-compressed length of output shaft	18
Checking/adjusting fully-compressed length of input shaft	19
Checking/adjusting fully-compressed length of selector drum	20
Shimming selector shaft	21
Assembling gearbox	22
Installing input, output and intermediate shaft	22
Installing selector shaft	23
Installing selector drum	23
Assembling gearbox housing	24



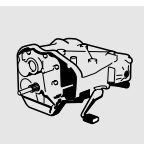



Technical data	R 850 C	R 1200 C
Type of gearbox	5-speed gearbox with claw-action shift and integral reaction damper for all gears	
Gear shift type	Pedal-operated lever and selector drum with overshoot detent	
Gear ratios		
1st gear	3.864	
2nd gear	3.022	
3rd gear	2.393	
4th gear	1.962	
5th gear	1.511	
Oil grade (all the year round)	Brand-name SAE 90 hypoid gear oil, API Class GL 5	
Filling capacity	Initial filling 1 l (Imp. pint/US quart) (1.76/1.06) (up to the lower edge of the filler hole) During oil changes approx. 0.8 +0.2 l (Imp. pint/US quart) (1.41 +0.35/0.85 +0.21) (up to the lower edge of the filler hole)	
Endplay of spring segment at input shaft	mm (in)	0.4...0.6 (0.0157...0.0236)
Endplay at 1st gear, output shaft	mm (in)	0.1...0.33 (0.0039...0.0130)
Endplay at 2nd gear, output shaft	mm (in)	0.1...0.33 (0.0039...0.0130)
Endplay, 3rd/4th gear (total play), output shaft	mm (in)	0.1...0.67 (0.0039...0.0264)
Selector shaft endplay	mm (in)	0.1...0.3 (0.0039...0.0118)
Length of intermediate shaft, fully compressed	mm (in)	198.95...199.00 (7.833...7.835)
Length of output shaft, fully compressed	mm (in)	192.95...193.00 (7.597...7.599)
Length of input shaft, fully compressed	mm (in)	138.55...138.60 (5.455...5.457)
Length of selector drum, fully compressed	mm (in)	111.80...111.90 (4.402...4.406)

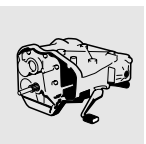

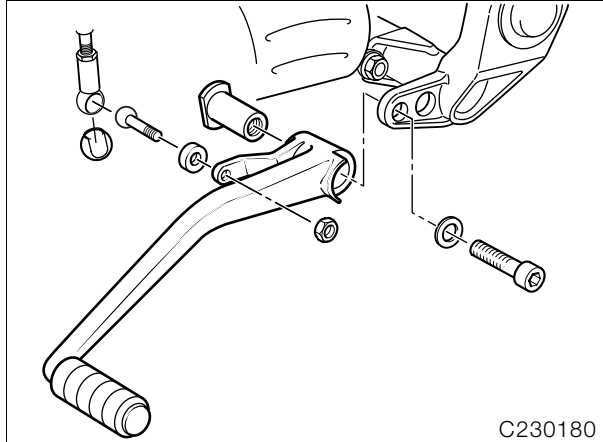

Removing and installing gear pedal



 **Tightening torque:**
 Gear pedal to frame 41 Nm

Removing gearbox

 **Caution:**
 Switch off ignition.
 Disconnect earth (ground) lead from battery.
 Insulate earth (ground) lead.

- Attach stand, **BMW No. 00 1 520**, to motorcycle.
- Remove seat.
- Remove side trim.
- Remove fuel tank.
- Remove rear wheel.
- Detach rear brake caliper.
- Detach ABS sensor.
- Detach speedometer signal sensor.
- Detach wire protection at swinging arm.
- Tie up swinging arm with a suitable strap.
- Remove suspension strut.

 **Note:**
 Press to rear at top.

- Pull swinging arm upwards with strap.
- Removing exhaust manifold.
- Remove silencer (muffler).
- Detach plug at oxygen sensor.
- Remove rear wheel drive unit.

- Detach brake hose holder.

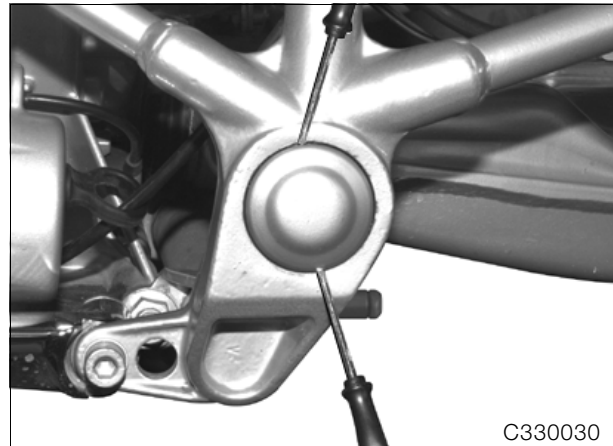

- Press off left swinging arm bearing cap.

 **Caution:**
 When installing again, make sure that the O-ring is in good condition.
 The opening must face down so that water can drain out.

- Loosen the left swinging arm.
- Take out the screws at the right swinging arm bearing.

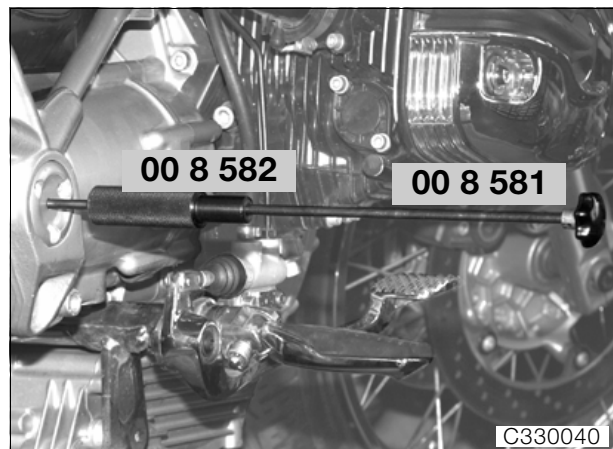

- Using pull rod, **BMW No. 00 8 581**, and impact weight, **BMW No. 00 8 582**, pull out the swinging arm bearing.
- Remove the left swinging arm bearing.
- Remove rear swinging fork.
- Remove the rubber intake pipe sleeves.
- Remove brake fluid reservoir from holder.
- Remove the holder.
- Detach the right plug holder plate.
- Pull off the NTC air plug.
- Detach the gear pedal at the pivot.
- Separate the throttle potentiometer and throttle angle positioner plugs at the left plug holder plate.
- Disconnect both fuse boxes at the plug holder plate.



- Separate the side (prop) stand swithc plug.
- Separate the neutral indicator plug.
- Detach the left plug holder plate.
- Remove the injectors.
- Pull the plugs off the injector lines.
- Disconnect the brake light switch plug and detach the cable.
- Detach the breather hose at the air cleaner casing.
- Detach the throttle cable at the twistgrip.
- Remove rear section of frame.
- Detach the footrest assembly.
- Remove the starter motor cover.
- Detach the positive lead from the starter motor.
- Remove the battery.
- Unscrew rear battery mount.
- Raise the battery holder at the rubber mount.
- Detach the clutch slave cylinder mount and pull out of the gearbox.
- Pull out the thrust rod.
- Detaching the gearbox

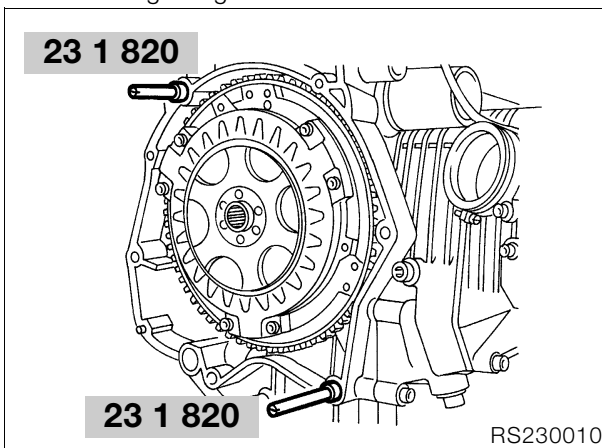

- When removing, pull the gearbox out on guide pins, **BMW No. 23 1 820**.
- Install by following the above work instructions in the reverse order.

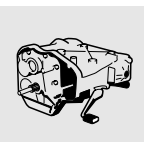

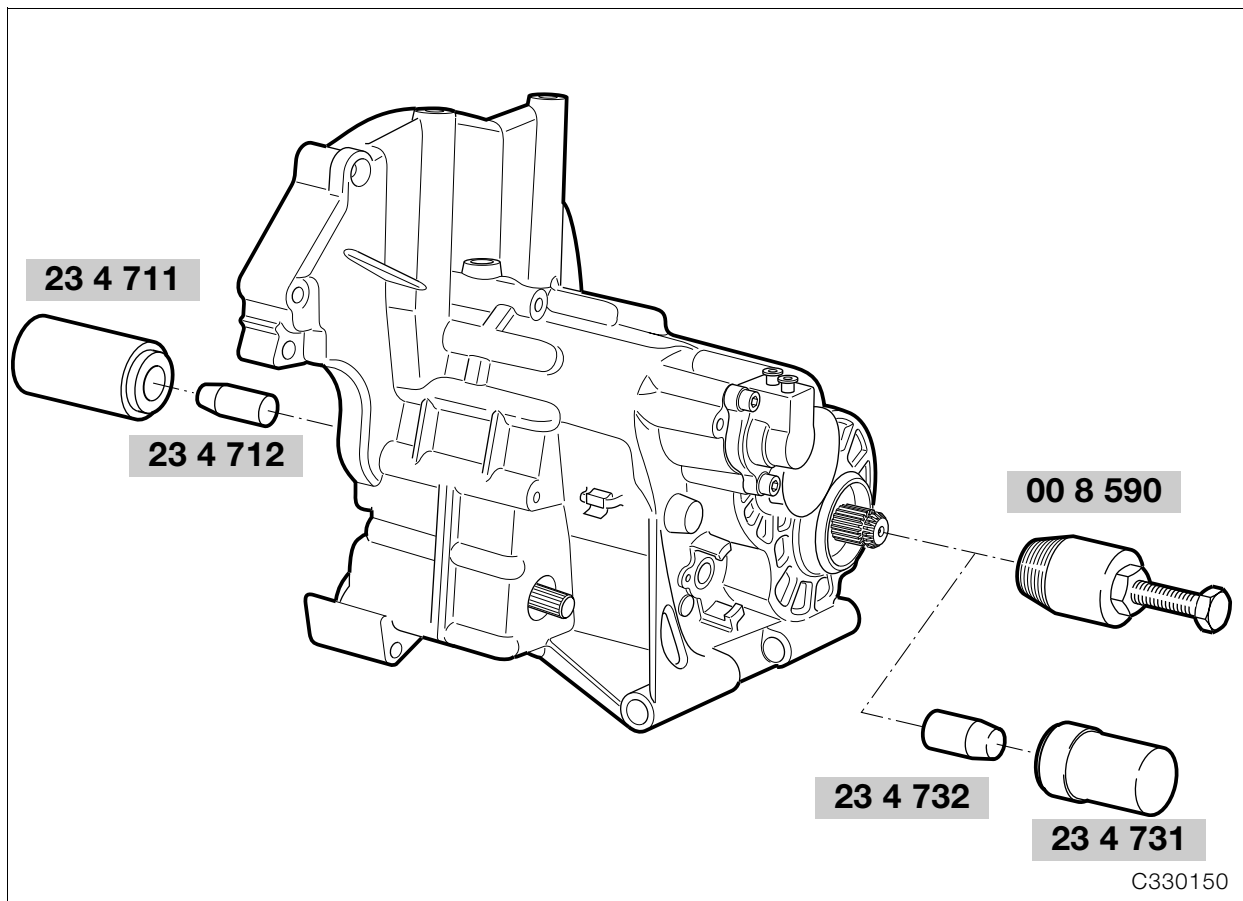

C330150

Renewing the shaft sealing rings in the gearbox housing and gearbox cover



Note:

All shaft sealing rings can be renewed with the gearbox installed, apart from the input-side shaft sealing ring on the input shaft.

If the gearbox is dismantled completely, all shaft sealing rings must be renewed.

Before installing shaft sealing rings, oil their sealing lips lightly.

Renew the input shaft sealing ring at the input end

- Lever the shaft sealing ring out with a screwdriver.
- Drive the new sealing ring in with the sealing lips facing inwards, using slip-over sleeve, **BMW No. 23 4 712**, and drift, **BMW No. 23 7 711**.

Renewing output shaft sealing ring



Caution:

Never use a sharp tool to remove the output shaft sealing ring, or the plastic washer on the deep-groove ball bearing behind the shaft sealing ring could be damaged.

- Pull the shaft sealing ring out with puller, **BMW No. 00 8 590**.
- Install the sealing ring with the sealing lips facing inwards, using slip-over sleeve, **BMW No. 23 4 732**, and drift, **BMW No. 23 4 731**.



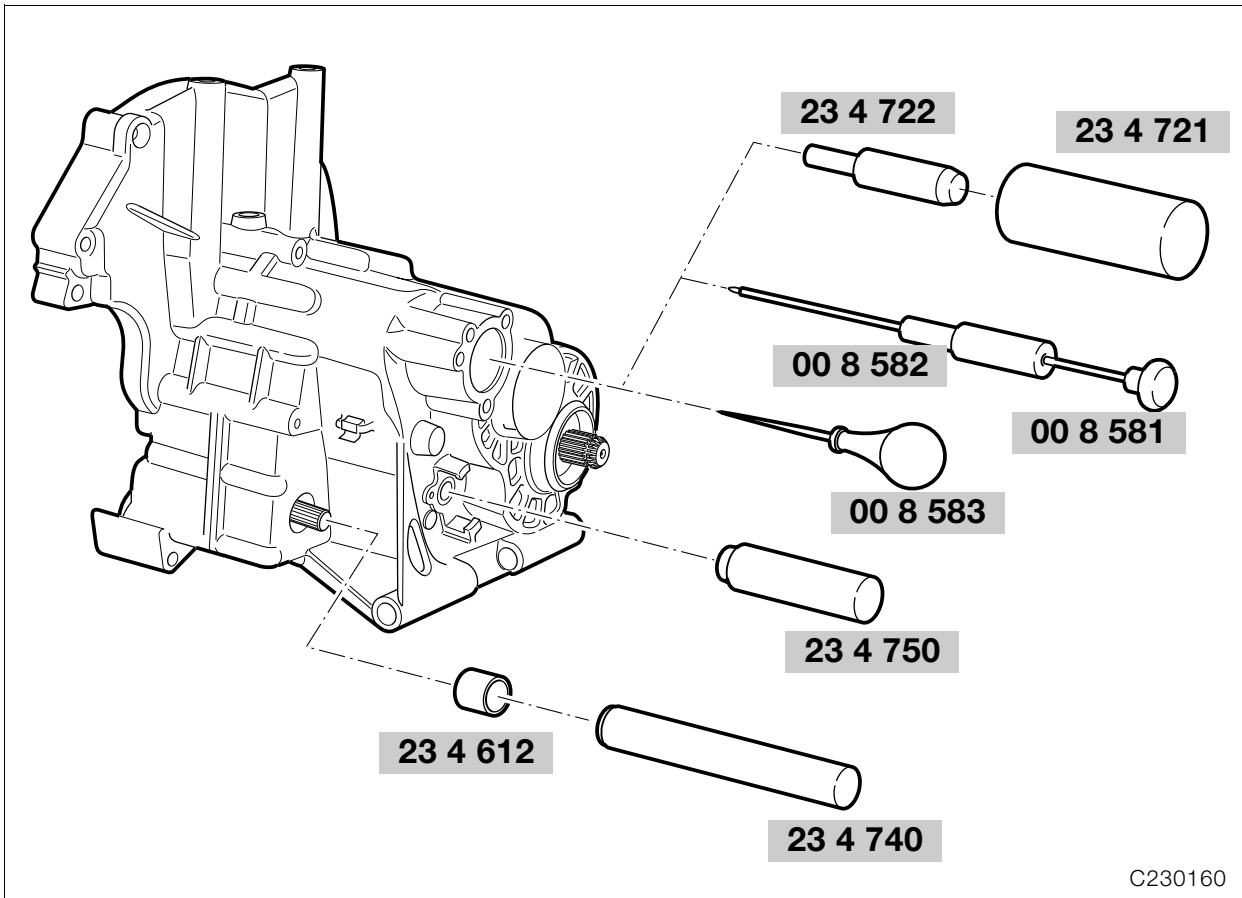

C230160

Renewing input shaft sealing ring at output side

- Pierce the shaft sealing ring with piercing tool, **BMW No. 00 8 583**.
- Screw the pull rod, **BMW No. 00 8 581**, into the pierced hole and use impact weight, **BMW No. 00 8 582**, to remove the shaft sealing ring.
- Install the new sealing ring with the sealing lips facing inwards, using guide pin, **BMW No. 23 4 722**, and impact driver, **BMW No. 23 4 721**.

Renewing shaft sealing ring for selector drum

- Lever the shaft sealing ring out with a screwdriver.
- Install the new sealing ring with the sealing lips facing inwards, using impact driver, **BMW No. 23 4 750**.

Renewing sealing ring for selector shaft

- Lever the shaft sealing ring out with a screwdriver.
- Install the new sealing ring with the sealing lips facing inwards, using slip-over sleeve, **BMW No. 23 4 612**, and impact driver, **BMW No. 23 4 740**.

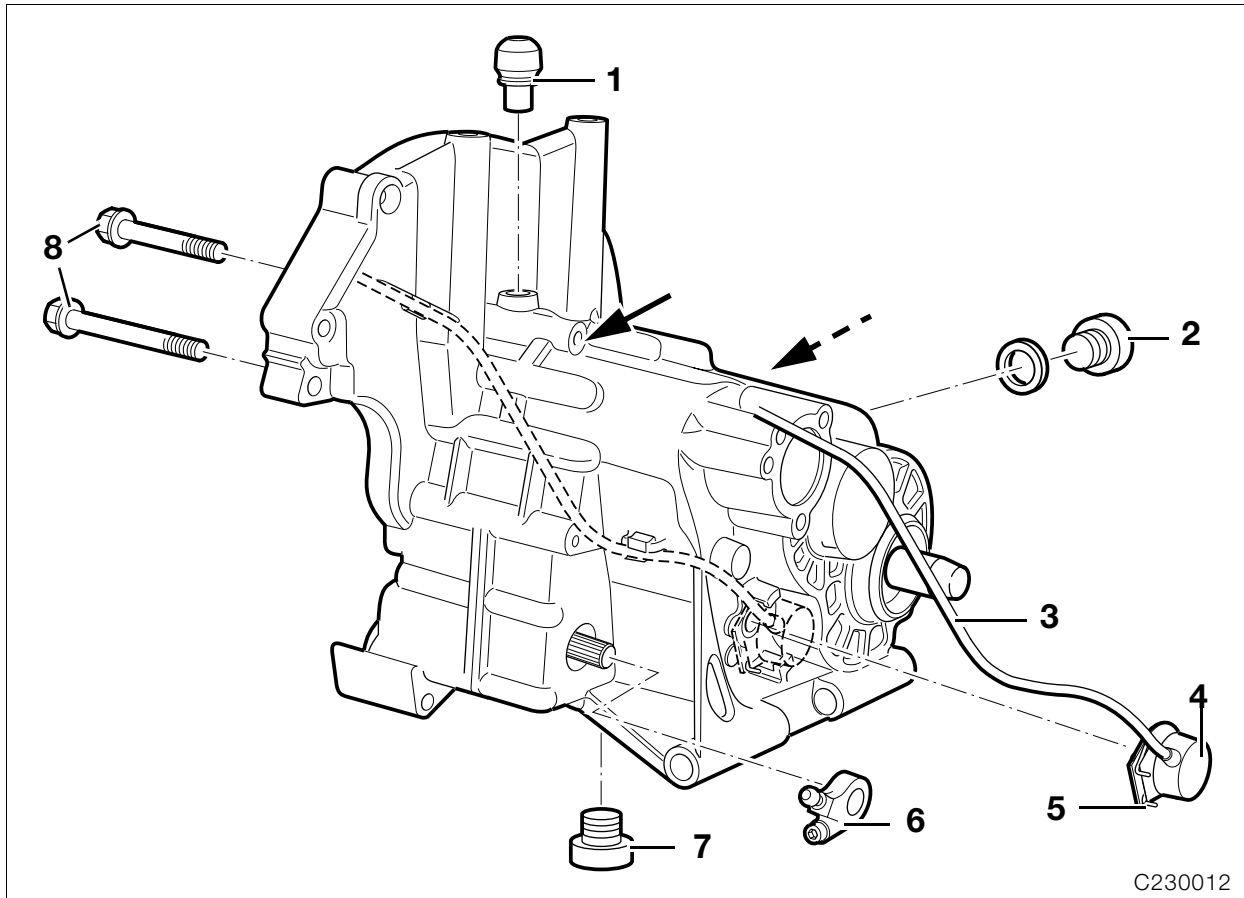

C230012

Dismantling gearbox

Removing gearbox housing

- Take out oil filler/level check screw (2).
- Take out oil drain plug (7) and drain the oil out of the gearbox into a suitable tray.
- Remove breather (1).
- Unclip cable (3) for neutral indicating switch (4).
- Compress spring (5) and take off neutral indicating switch (4).
- Remove selector lever (6).
- Carefully press back centering pins (arrows), working from the back of the gearbox.
- Remove screws (8) securing cover to housing.

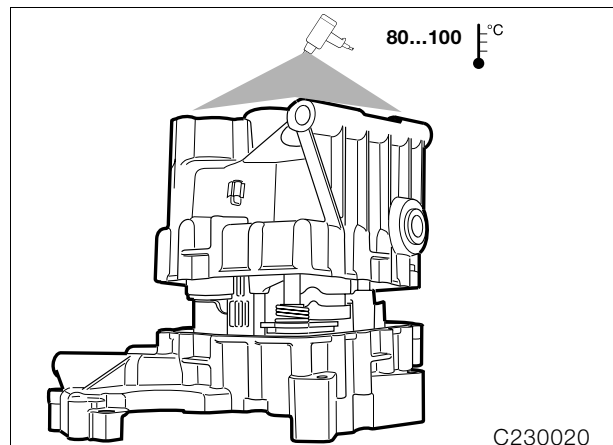

C230020

- Set the gearbox down on its cover.



Caution:

Avoid damage to the housing cover and painted surfaces.

- Heat the bearing points in the housing to 80 °C... 100 °C (176 °F...212 °F).
- Strike lightly with a plastic-faced hammer to release the gearbox.

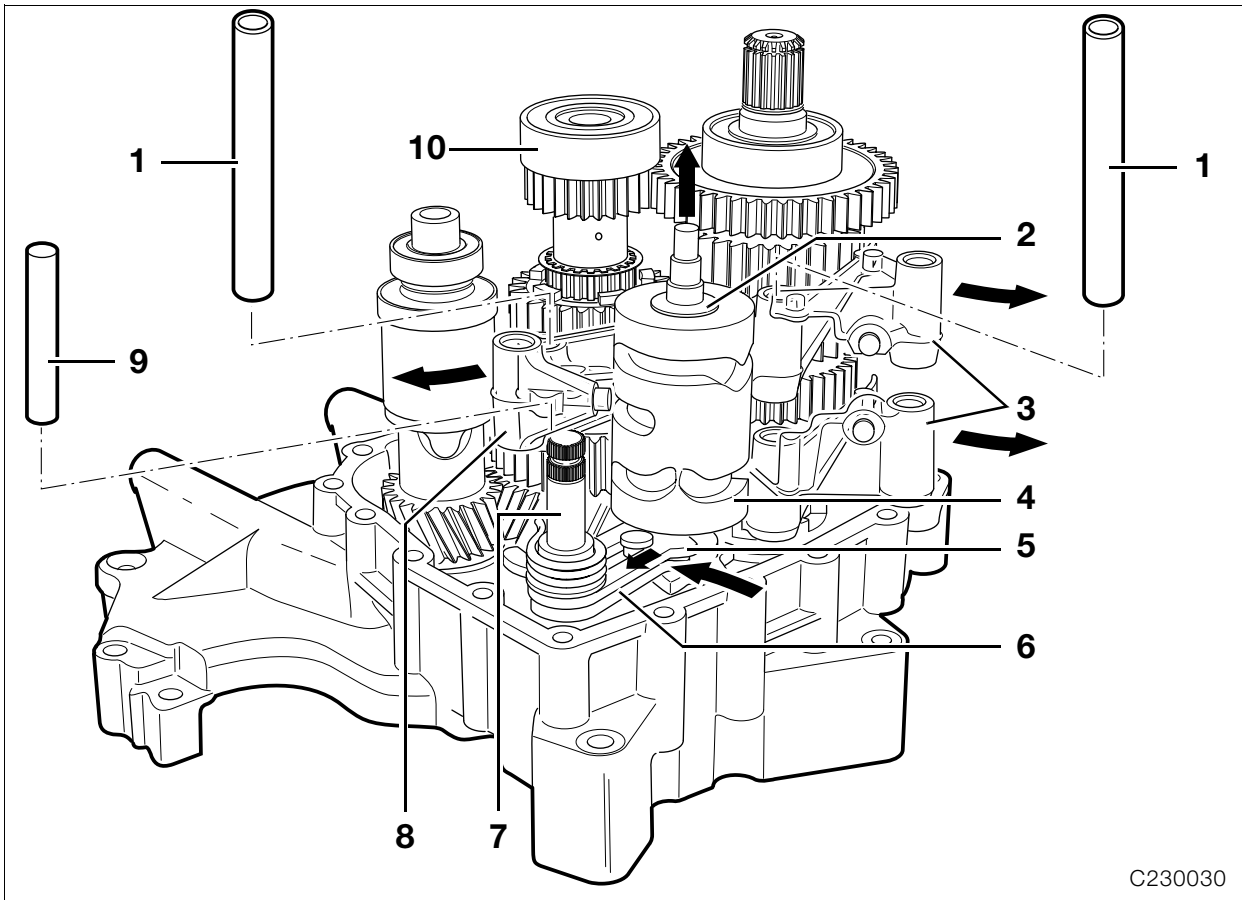

C230030

Removing selector drum

- Pull the selector shafts (1) out of the selector forks.
- Swing the selector forks (3/8) out towards the edge of the cover (arrows).
- Remove locking pin (9).
- Press guide plate (5) in the opposite direction to the spring loading (arrow).
- Swing locking lever (6) towards input shaft (7), hold it there and pull out the selector drum (4), turning it slightly at the same time.
- Remove the thrust washers and spacing washer.
- Release the locking lever (6).
- Remove the selector shaft (7) with spacing washer.
- Remove selector forks (3).
- Selector fork (8) remains in the intermediate shaft (10).

Dismantling/assembling selector shaft

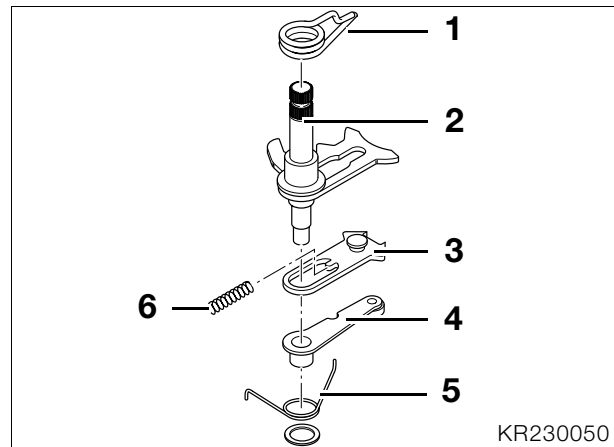

KR230050

- Remove torsion spring (5) with locking lever (4) from selector shaft (2).
- Remove torsion spring (1).
- Remove coil spring (6) and take off together with sliding plate (3).
- Assemble in the opposite order of work.

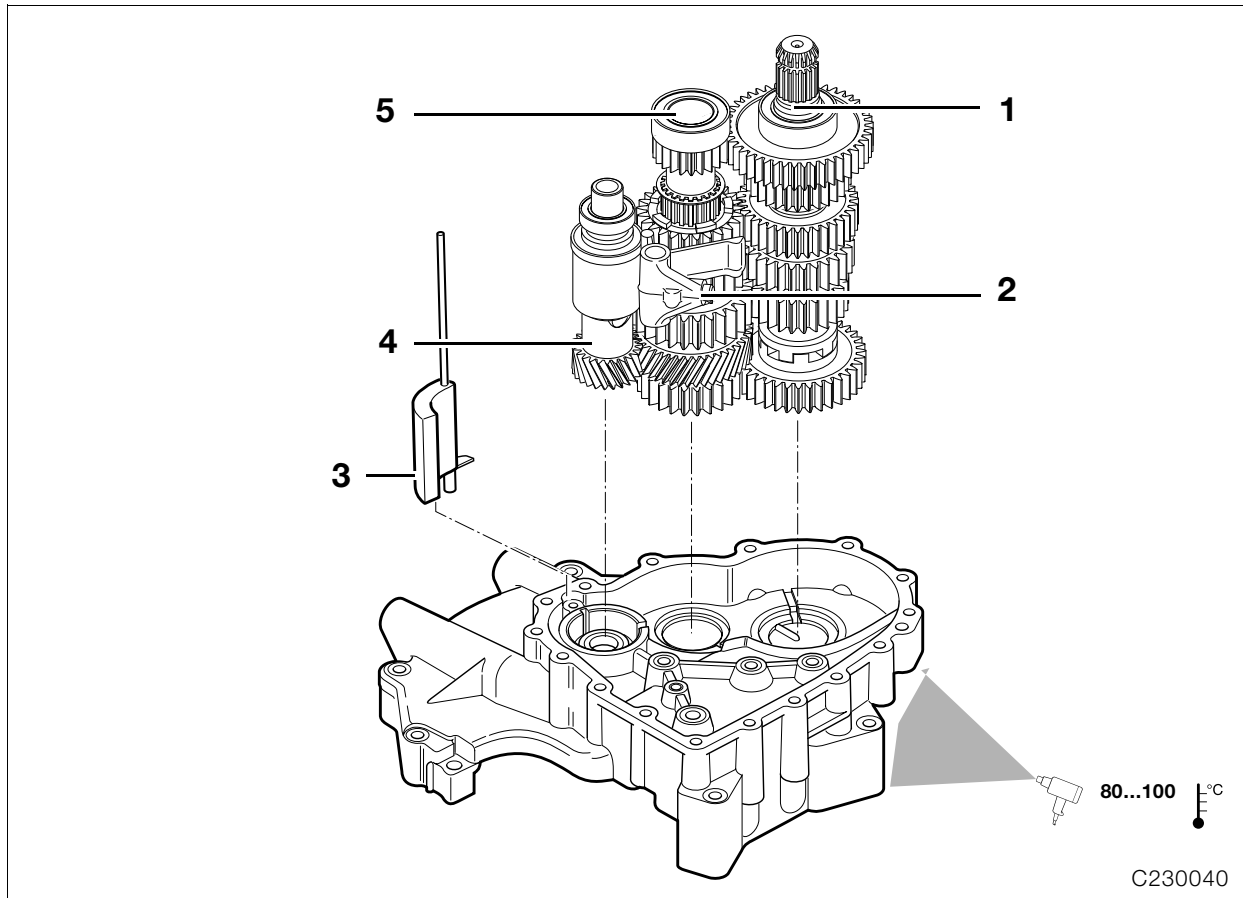

Removing gearbox shafts

- Remove breather tube (3).
- Heat bearing points in gearbox cover to 80 °C ... 100 °C (176 °F ... 212 °F).
- Take off input shaft (4), output shaft (1) and intermediate shaft (5) together from the cover.
- Remove selector fork (2) from intermediate shaft.

Renewing deep-groove ball bearing on intermediate shaft

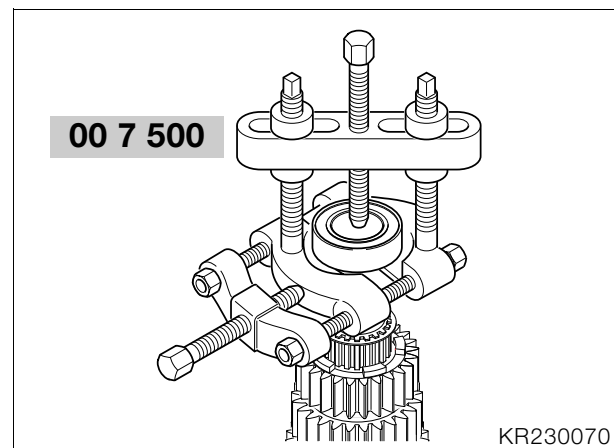

Caution:

If the deep-groove ball bearings are renewed, the fully-compressed length must be re-adjusted.

- Pull off the deep-groove ball bearings with a universal puller, **BMW No. 00 7 500**.
- Press the output-side deep-groove ball bearing on to the intermediate shaft.
- Check/adjust fully-compressed length (→ 23.17).
- Place the spacing washer of the determined thickness in position and press on the input-side deep-groove ball bearing.

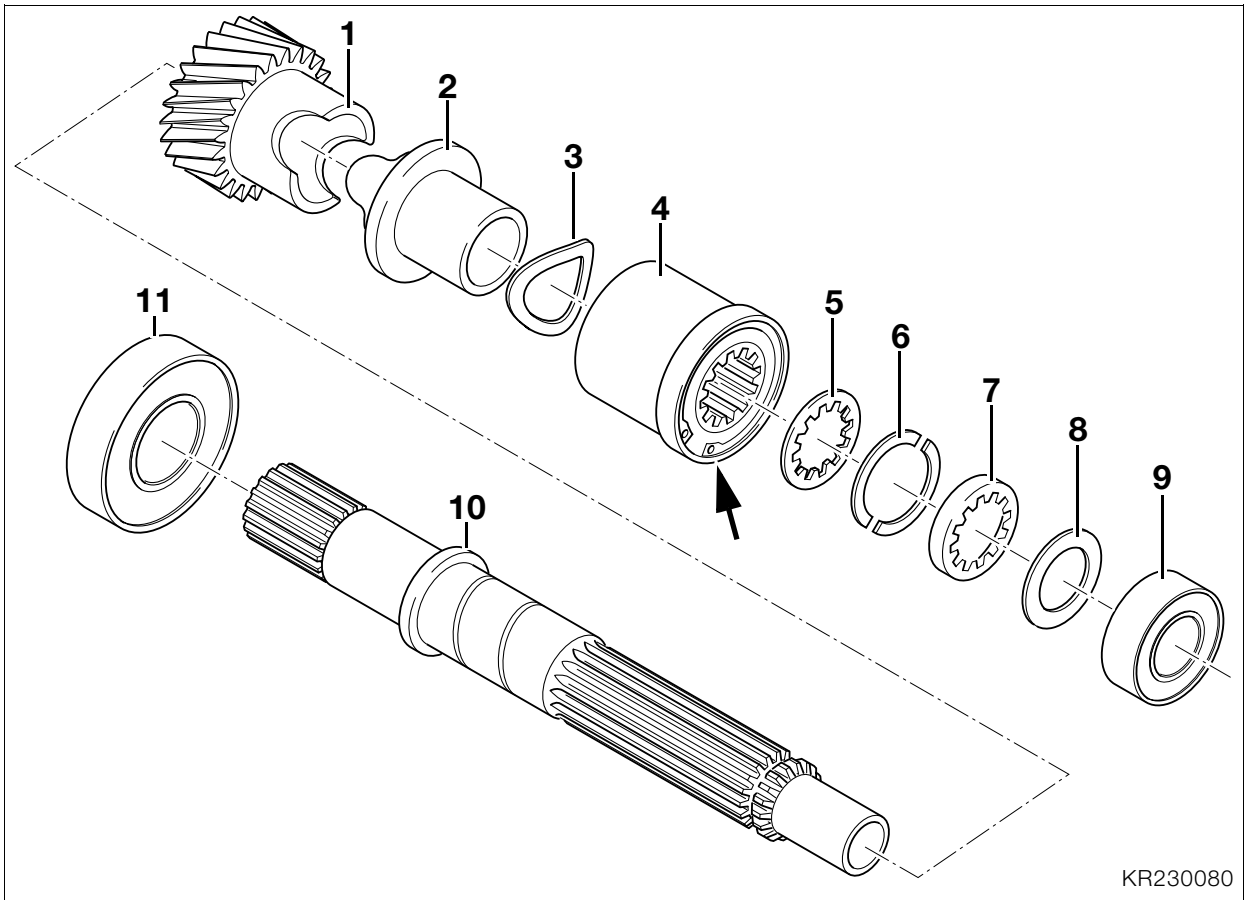

KR230080

Dismantling/assembling input shaft

Dismantling input shaft

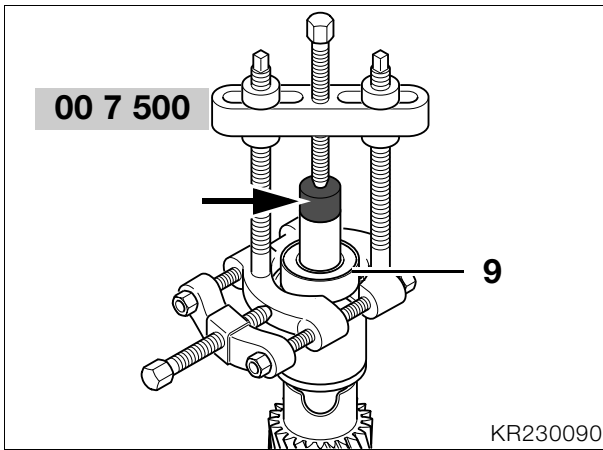

KR230090

- Remove guide ring (7).
- Compress spring cluster (4) and remove split segment washer (6).
- Remove support disc (5), spring cluster (4), anti-rattle disc (3), thrust block (2) and constant-speed gear (1).
- Transfer input shaft (10) to a different position.
- Use universal puller, **BMW No. 00 7 500**, and pressure head (arrow) to pull off deep-groove ball bearing (11).

- Clamp the input shaft into the vise, using soft jaws.
- Use universal puller, **BMW No. 00 7 500**, and pressure head (arrow) to pull off deep-groove ball bearing (9) with spacing washer (8).
- Note the thickness of spacing washer (8).

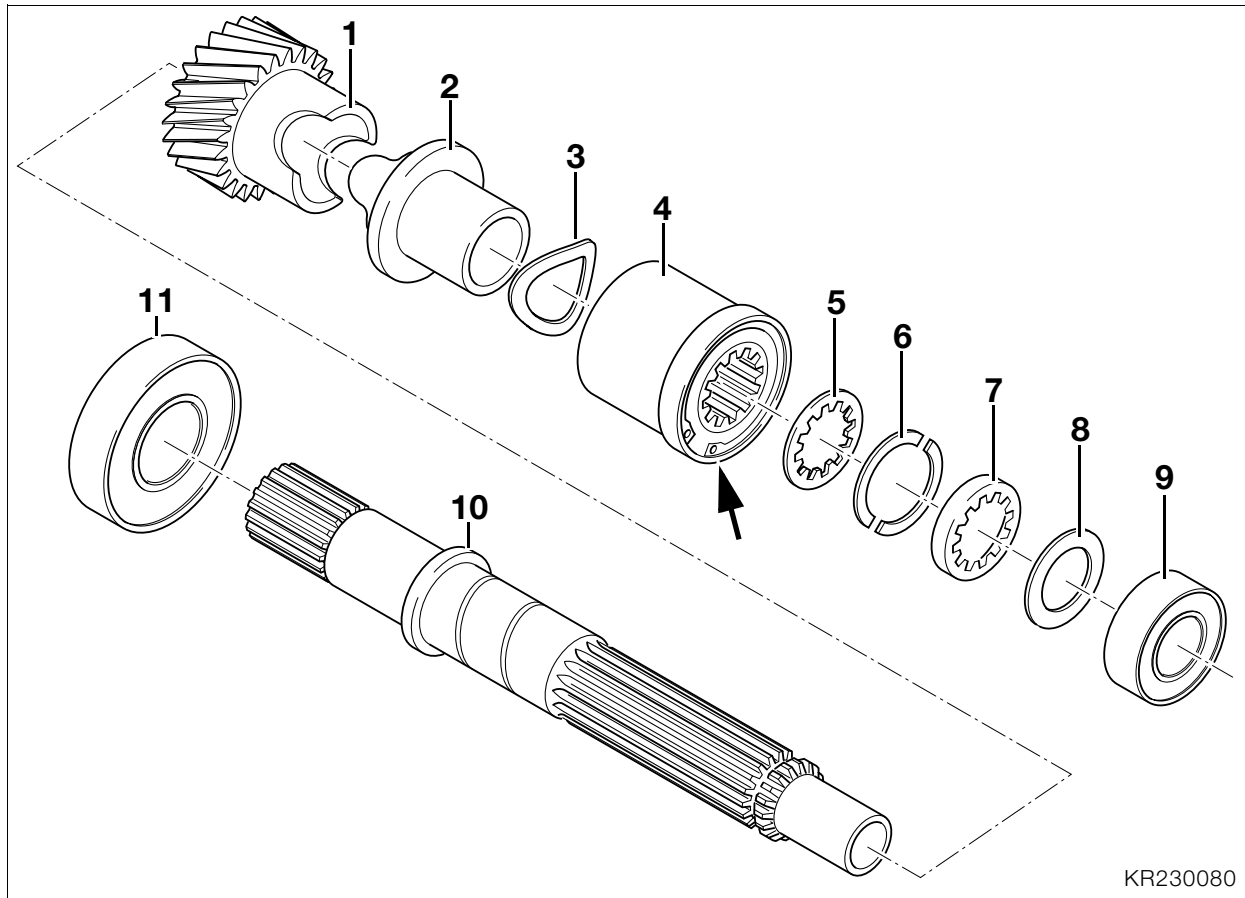

KR230080

Assembling input shaft

- Oil the bearing surface for constant-speed gear (1) lightly on input shaft (10), and install the constant-speed gear.
- Oil the splines in thrust block (2) lightly and install it.
- Place anti-rattle disc (3) on thrust block (2).
- Mount spring cluster (4) and circlip (arrow) facing upwards on anti-rattle disc (3).
- Install a support disc (5) of the same thickness as the one previously removed.
- Compress spring cluster (4) and insert the split segment washer (6) in the ring groove.
- Install guide ring (7) with shoulder facing over segment disc (6).
- Check fully-compressed length and adjust if necessary (→ 23.19).
- Install spacing washer (8) of the determined thickness, and press on deep-groove ball bearing (9).
- Check endplay of spring cluster (4).



Note:

If endplay is greater than the tolerance limit, the cause may be wear or incorrect assembly.

Endplay:

Spring cluster on shaft 0.4...0.6 mm (0.016...0.024 in)



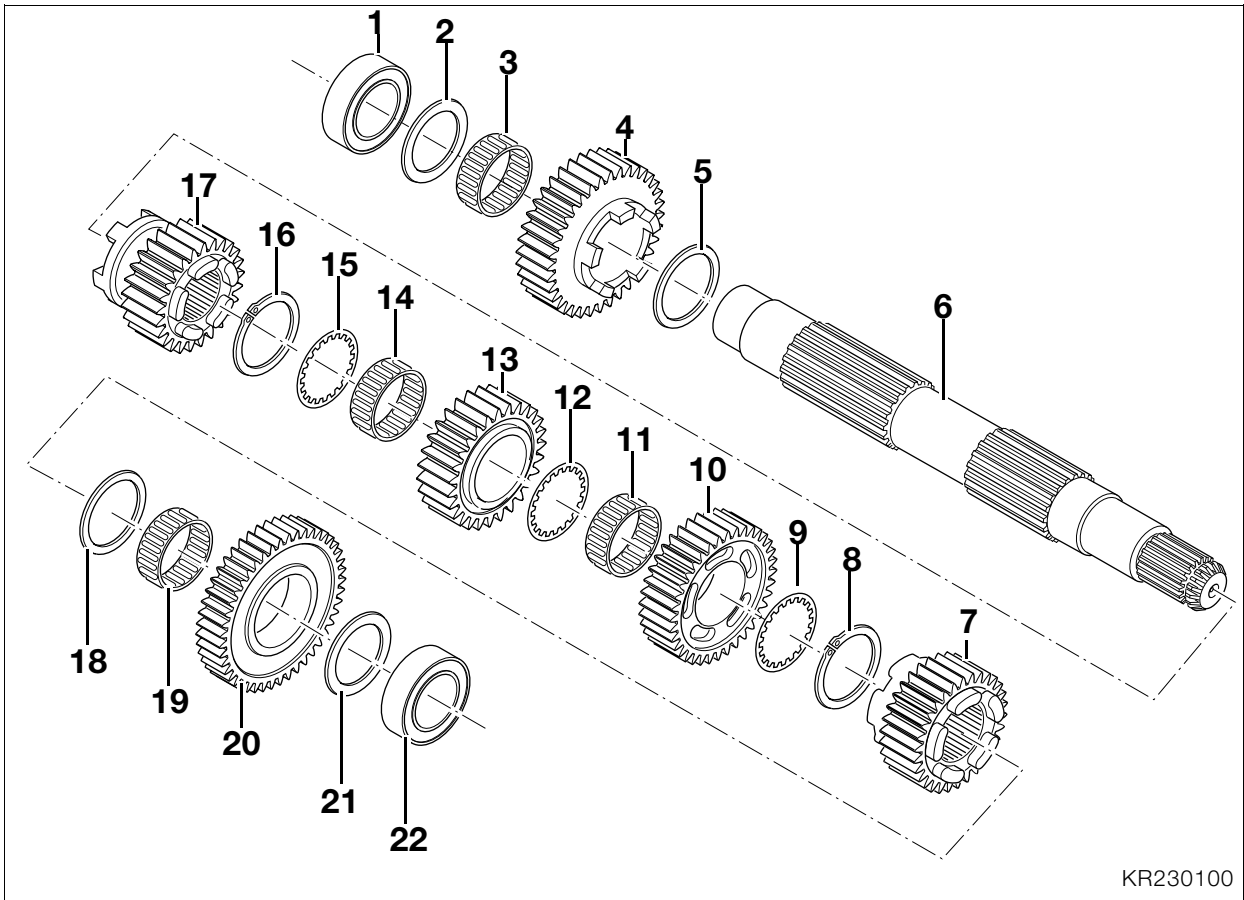

KR230100

Dismantling/reassembling output shaft

Stripping down output shaft



Caution:

To avoid damaging the needle roller bearing at the splines, open it out carefully at the joint line before removing.

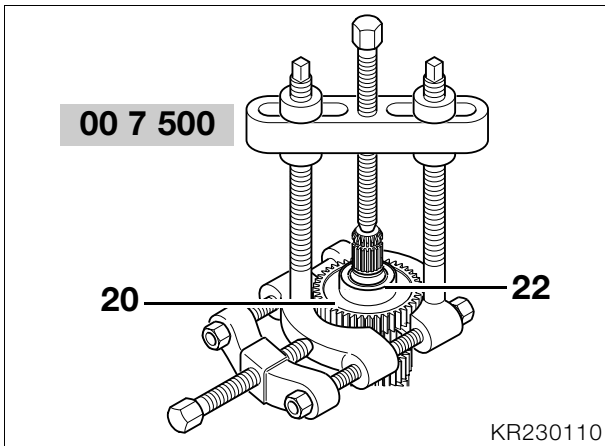

KR230110

- Using universal puller, **BMW No. 00 7 500**, pull off deep-groove ball bearing (22) together with 1st gear wheel (20).

- Remove spacing washer (21), shift gear wheel for 1st gear (20), needle roller bearing (19) and spacing washer (18).
- Remove sliding gearwheel (7).
- Remove circlip (8), support washer (9), shift gearwheel for 3rd gear (10) and needle roller bearing (11).
- Remove support washer (12), 4th gear shift wheel (13), needle roller bearing (14) and support washer (15).
- Remove circlip (16) and sliding gearwheel for 5th gear (17).
- Turn output shaft (6) and clamp into the vise with soft jaws.
- Using universal puller, **BMW No. 00 7 500**, pull off deep-groove ball bearing (1) together with shift gearwheel for 2nd gear (4).
- Remove shim washer (2), needle roller bearing (3), shift gearwheel for 2nd gear (4) and thrust washer (5).

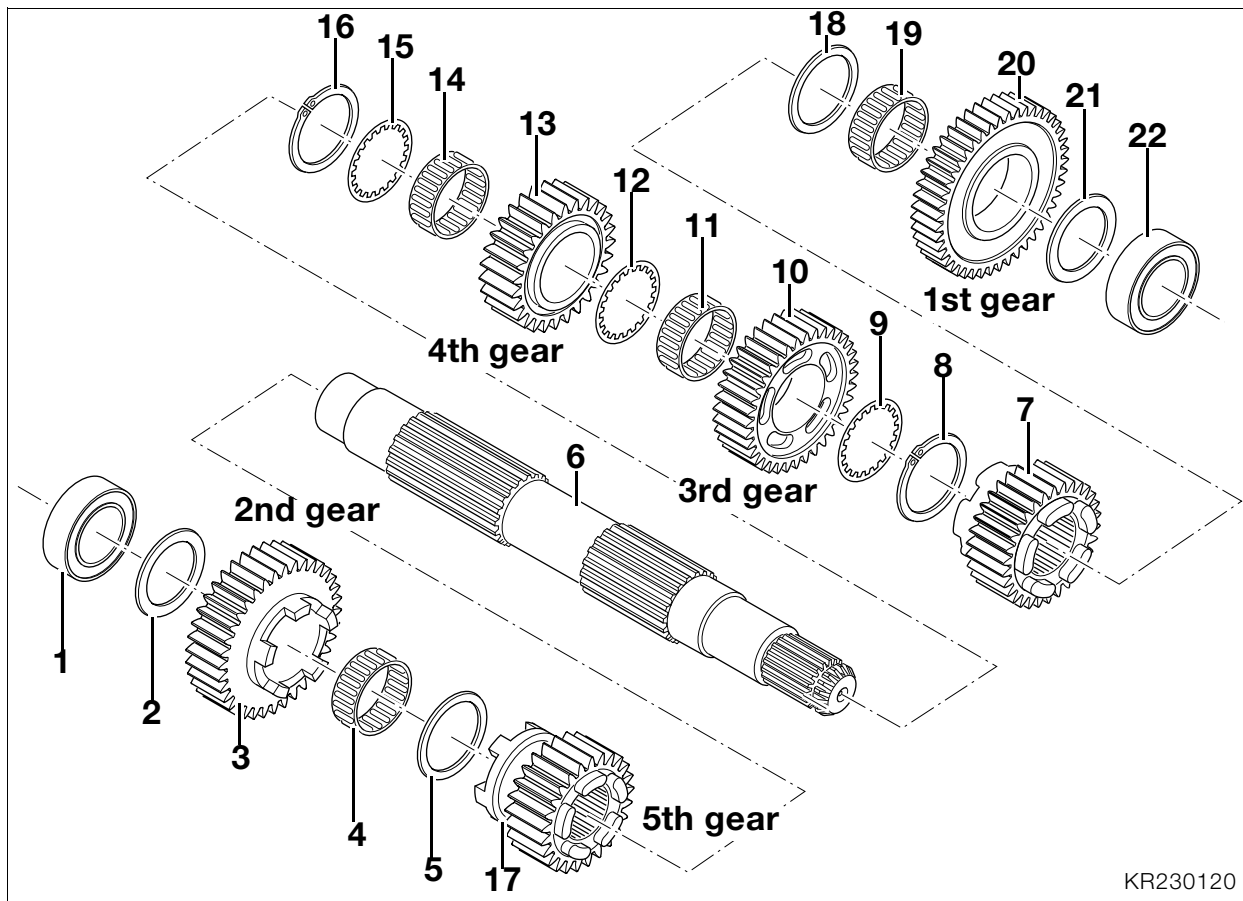

KR230120

Assembling output shaft



Note:

Assembly starts at the shift gearwheel for 4th gear. Before assembly, oil all running surfaces lightly with gear oil.

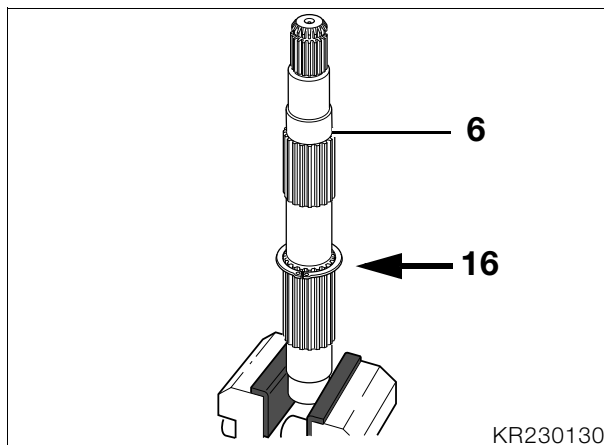

KR230130

- Clamp the output shaft into the vise with soft jaws and with the splines facing upwards.
- Install circlip (16/arrow).
- Install thrust washer (15).

- Install needle roller bearing (14).



Caution:

To avoid damaging the needle roller bearing at the splines, spread it carefully at the butt joint before installing.

- Install shift wheel for 4th gear (13) with the pockets facing circlip (16).
- Install support washer (12) and needle roller (11).
- Install shift wheel for 3rd gear (10) with pockets facing away from the 4th gear shift wheel (13).
- Install support washer (9) and circlip (8).
- After installing the 3rd and 4th shift gearwheels, measure endplay (→ 23.16).
- Install sliding gear (7) with the recess for the selector fork facing the shift gearwheel for 3rd gear (10).
- Install support washer (18) and needle roller bearing (19).
- Install the shift gearwheel for 1st gear (20) with the pockets facing sliding gearwheel (7).
- Install spacing washer (21) and deep-groove ball bearing (22).
- After installing, check endplay at the shift gearwheel for 1st gear (→ 23.16).



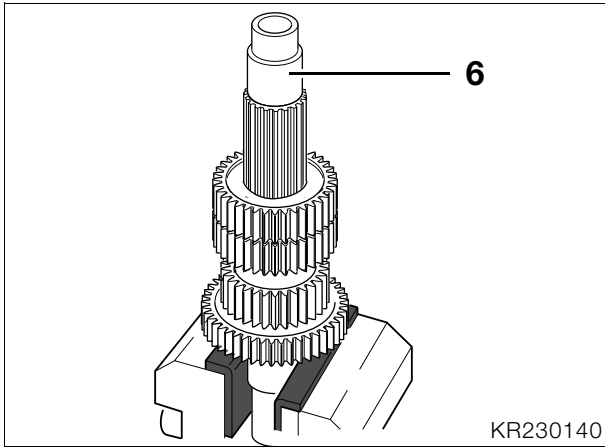

- Transfer output shaft (6) to new position in vise.
- Install shift wheel for 5th gear (17) with the recess for the selector fork facing the 2nd gear shift wheel (3).
- Install support washer (5) and needle roller bearing (4).
- Install the shift wheel for 2nd gear (3) with the dogs facing the 5th gear shift wheel (17).
- Check/adjust the fully-compressed length (→ 23.19).
- Install spacing washer (2) of the determined thickness, and press on deep-groove ball bearing (1).
- Check endplay at 2nd (→ 23.16).

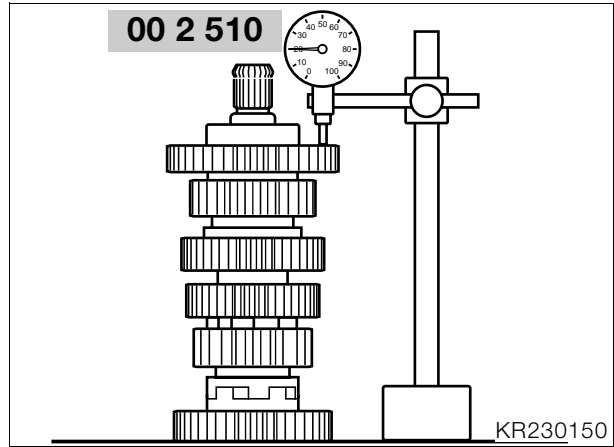

Checking endplay

- Attach dial gauge, **BMW No. 00 2 510**, to dial gauge stand.
- Apply the dial gauge to the edge of the gear-wheel and check endplay.



Caution:

If endplay is beyond the permitted tolerances, this indicates either an assembly error or wear in the needle roller bearings, the support or spacing washers or the shift gear. Check for wear and renew the affected parts.

Endplay values:

Endplay, 1st gear ..0.1...0.33 mm (0.004...0.013 in)
 Endplay,
 2nd gear 0.1...0.33 mm (0.004...0.013 in)
 Endplay, 3rd/4th gear
 (total play)..... 0.1...0.67 mm (0.004...0.026 in)

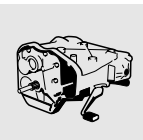

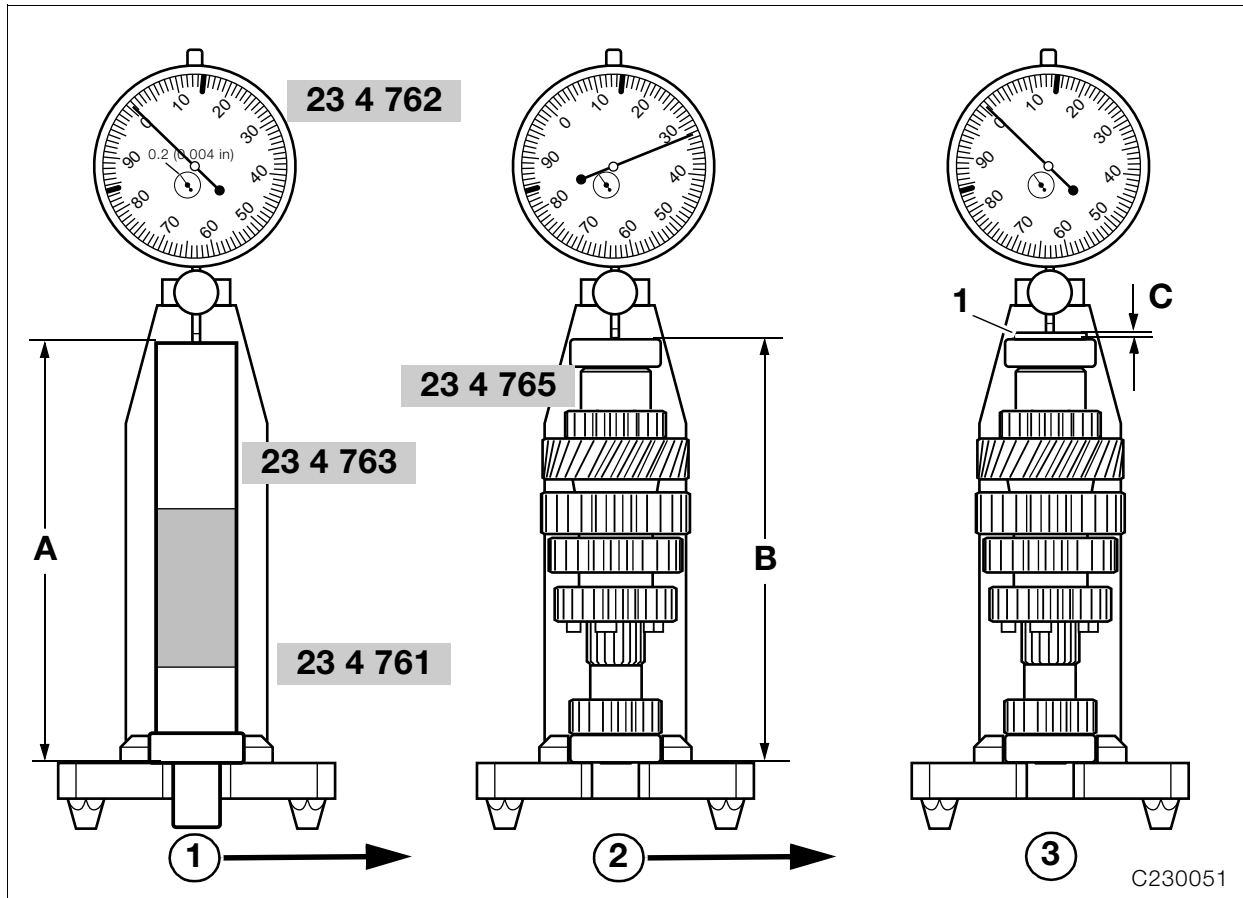

Checking/adjusting fully compressed length of gearbox shafts and selector drum

Checking/adjusting fully-compressed length of intermediate shaft

Caution:

To adjust and check the fully-compressed length, measure deviation from zero as described below and adjust with a shim washer. Before each measurement, even if the shaft is not being installed, make sure that the deep-groove ball bearing is fully compressed.

- Pull off the input-side deep-groove ball bearing with universal puller, **BMW No. 00 7 500**.
- Take off the spacing washer.
- Insert zero gauge, **BMW No. 23 4 763**, into measuring stand, **BMW No. 23 4 761**.
- Secure dial gauge, **BMW No. 23 4 762**, in rear mounting hole on measuring stand, **BMW No. 23 4 761**, and set to 0.2 mm (0.008 in) preload.
- Using the dial gauge, zero to dimension "A" of the zero gauge, **BMW No. 23 4 763**.
- Remove the zero gauge from the measuring fixture.
- Place measuring disc, **BMW No. 23 4 765**, on the intermediate shaft.
- Place deep-groove ball bearing on measuring disc.
- Insert intermediate shaft in measuring stand.

- Using dial gauge, measure deviation from zero of dimension "B" at inner bearing race. The deviation from zero is equivalent to the thickness "C" of spacing washer (1).
- Place a spacing washer (1) of the thickness just determined on the inner bearing race and check deviation from zero.

$$A = B + C$$

Caution:

The maximum permitted deviation from zero must not be exceeded.

- Remove the intermediate shaft from the measuring fixture.
- Take off spacing washer, the deep-groove ball bearing and the measuring disc.
- Place a spacing washer (1) of the determined thickness on the intermediate shaft and press on the deep-groove ball bearing.

Adjusting dimensions for intermediate shaft:

Maximum deviation from zero -0.05 mm (0.002 in) ... 0.00 mm/in
Fully-compressed length..... 198.95...199.00 mm (7.833...7.835 in)



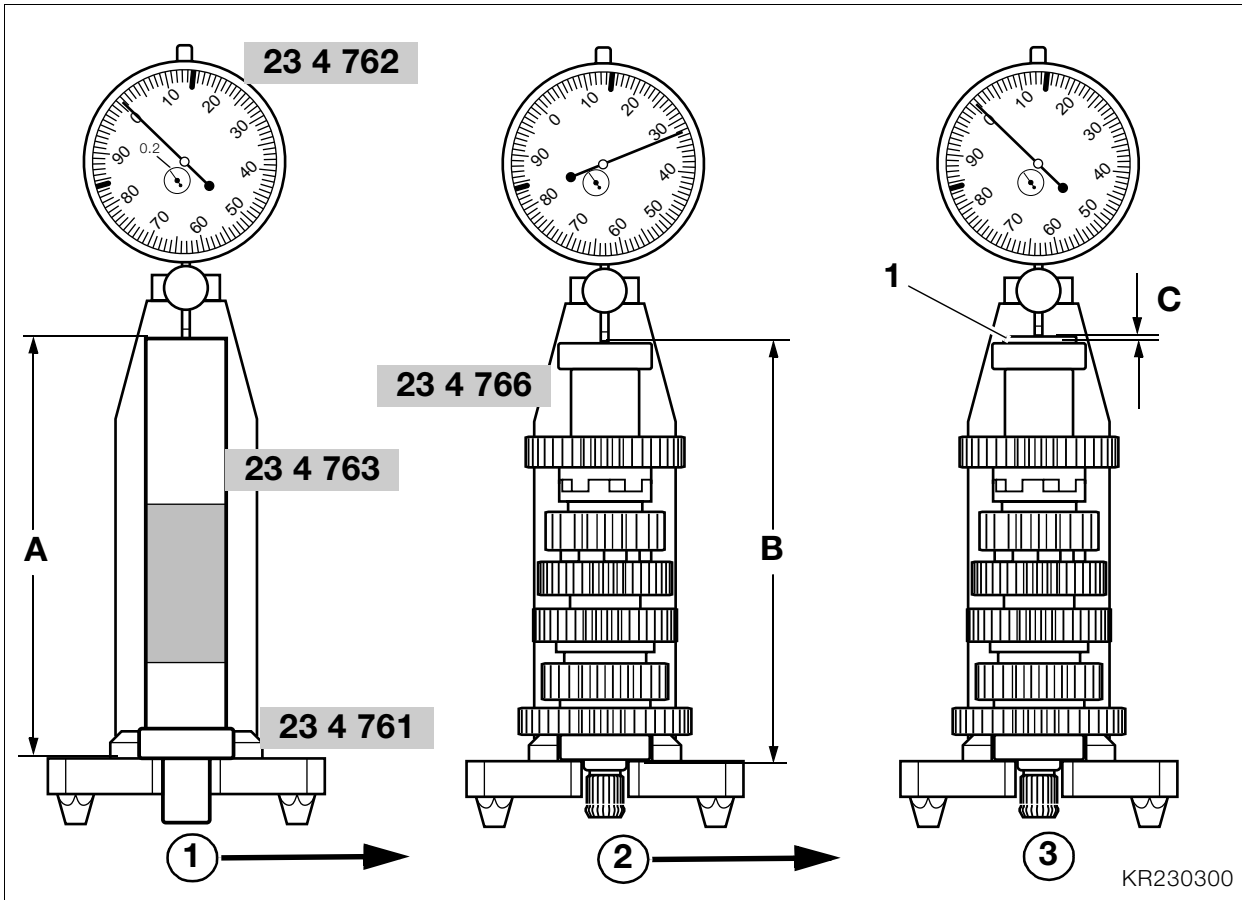

Checking/adjusting fully-compressed length of output shaft

⚠ Caution:

To check and adjust the fully-compressed length, measure deviation from zero as described below and adjust with a shim washer. Before each measuring step, even if the shaft is not to be installed, make sure that the deep-groove ball bearing is fully compressed.

- Pull off output-side deep-groove ball bearing with universal puller, **BMW No. 00 7 500**.
- Take off the spacing washer.
- Insert zero gauge, **BMW No. 23 4 763**, in to measuring stand, **BMW No. 23 4 761**.
- Secure dial gauge, **BMW No. 23 4 762**, in rear mounting hole on measuring stand, **BMW No. 23 4 761**, and set to 0.2 mm (0.008 in) preload.
- Using the dial gauge, zero to dimension "A" of the zero gauge, **BMW No. 23 4 763**.
- Remove the zero gauge from the measuring fixture.
- Place the measuring disc, **BMW No. 23 4 766**, on the output shaft.
- Place the deep-groove ball bearing on the measuring disc.
- Insert the output shaft into the measuring stand.

- Using the dial gauge, measure the deviation from zero of dimension "B" at the inner bearing race. The deviation from zero represents thickness "C" of spacing washer (1).
- Place spacing washer (1) of the thickness just determined on the inner bearing race, and check deviation from zero.

$$A = B + C$$

⚠ Caution:

The maximum deviation from zero must not be exceeded.

- Remove output shaft from measuring fixture.
- Take off spacing washer, deep-groove ball bearing and measuring disc.
- Place a spacing washer (1) of the determined thickness on the output shaft and press on the deep-groove ball bearing.

Output shaft adjusting dimensions:

Maximum deviation from zero -0.05 mm (0.002 in) ... 0.00 mm/in
Fully-compressed length..... 192.95...193.00 mm (7.596...7.598 in)

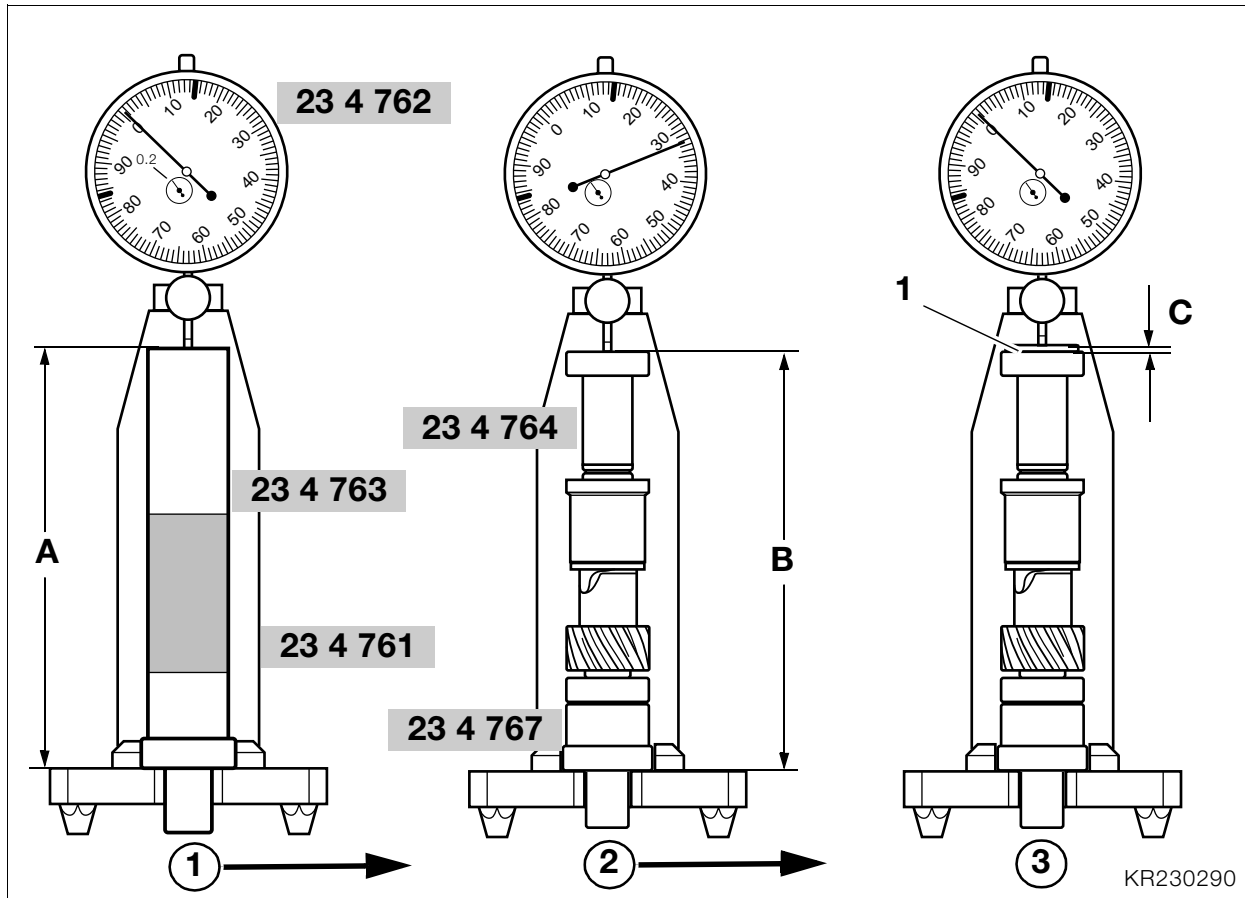

Checking/adjusting fully-compressed length of input shaft

Caution:

To adjust and check the fully-compressed length, deviation from zero must be measured as described below, and adjusted by means of a shim washer. Make sure before each measuring step, even if the shaft is not being installed, that the deep-groove ball bearing is fully compressed.

- Pull off output-side deep-groove ball bearing with universal puller, **BMW No. 00 7 500**.
- Take off the spacing washer.
- Insert zero gauge, **BMW No. 23 4 763**, into measuring stand, **BMW No. 23 4 761**.
- Secure dial gauge, **BMW No. 23 4 762**, in front mounting hole on measuring stand, **BMW No. 23 4 761**, and set to 0.2 mm (0.008 in) preload.
- Using dial gauge, zero to dimension "A" of the zero gauge, **BMW No. 23 4 763**.
- Remove the zero gauge from the measuring fixture.
- Mount measuring disc, **BMW No. 23 4 764**, on the input shaft.
- Place the deep-groove ball bearing on the measuring disc.
- Insert input shaft with adapter disc, **BMW No. 23 4 767**, in measuring stand.

- Using the dial gauge, measure deviation from zero to dimension "B" at the inner bearing race. The deviation from zero represents the thickness "C" of spacing washer (1).
- Place a spacing washer (1) of the determined thickness on the inner bearing race and check the deviation from zero.

$$A = B + C$$

Caution:

The maximum deviation from zero must not be exceeded.

- Take the input shaft out of the measuring fixture.
- Take off the adapter disc, spacing washer, deep-groove ball bearing and measuring disc.
- Place a spacing washer (1) of the determined thickness in position and press the deep-groove ball bearing on to the input shaft.

Adjusting dimensions for input shaft:

Maximum deviation
from zero -0.05 mm (0.002 in) ... 0.00 mm/in
Fully-compressed
length..... 138.55...138.60 mm (5.455...5.457 in)



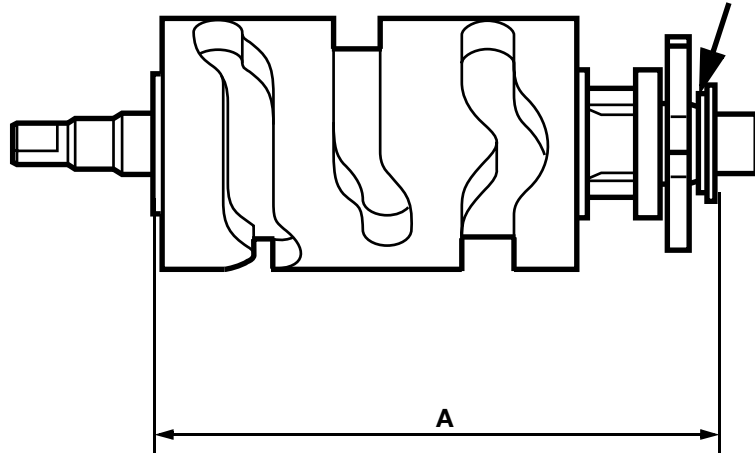

KR230190

Checking/adjusting fully-compressed length of selector drum

- Place spacing washer and both thrust washers on the selector drum.
- Using depth gauge, determine fully-compressed length "A".
- If necessary, adjust fully-compressed length "A" with a shim washer (arrow).

Fully-compressed length:

Selector drum 111.80...111.90 mm (4.402...4.406 in)

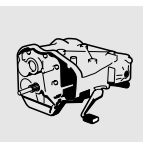

Shimming selector shaft



Caution:

If the housing or the complete selector shaft is renewed, the selector shaft must be measured and shimmed again.

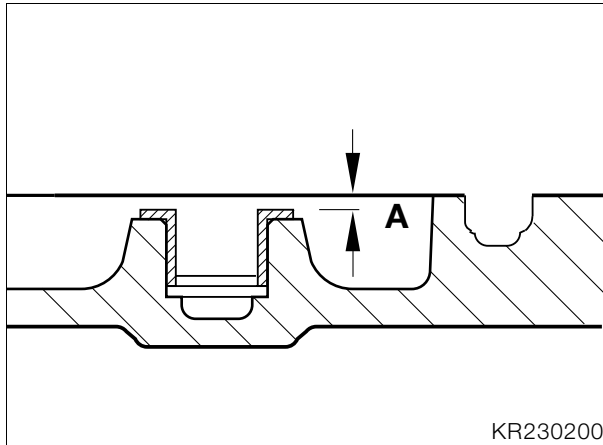

- Measure dimension "A" from shouldered bushing to cover joint face.

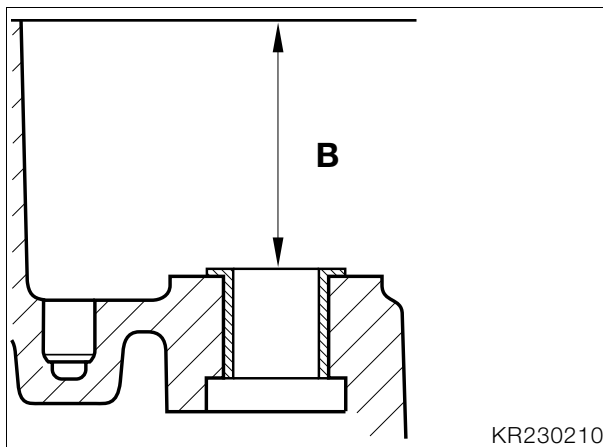

- Measure dimension "B" from shouldered bushing to housing joint face.

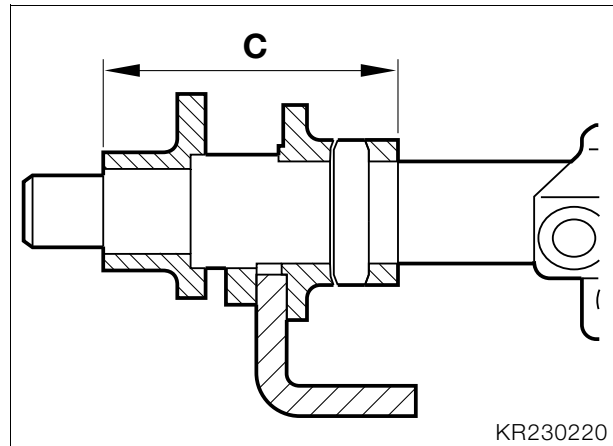

- Measure dimension "C" from the shoulder on the selector shaft to the back of the sleeve.
- Determine endplay as follows:

Dimensions "A" + "B" = "D"

Dimensions "D" - "C" = "E"

Dimensions "E" - thickness of spacing washer = endplay.

Endplay:

Selector shaft 0.1...0.3 mm (0.004...0.012 in)



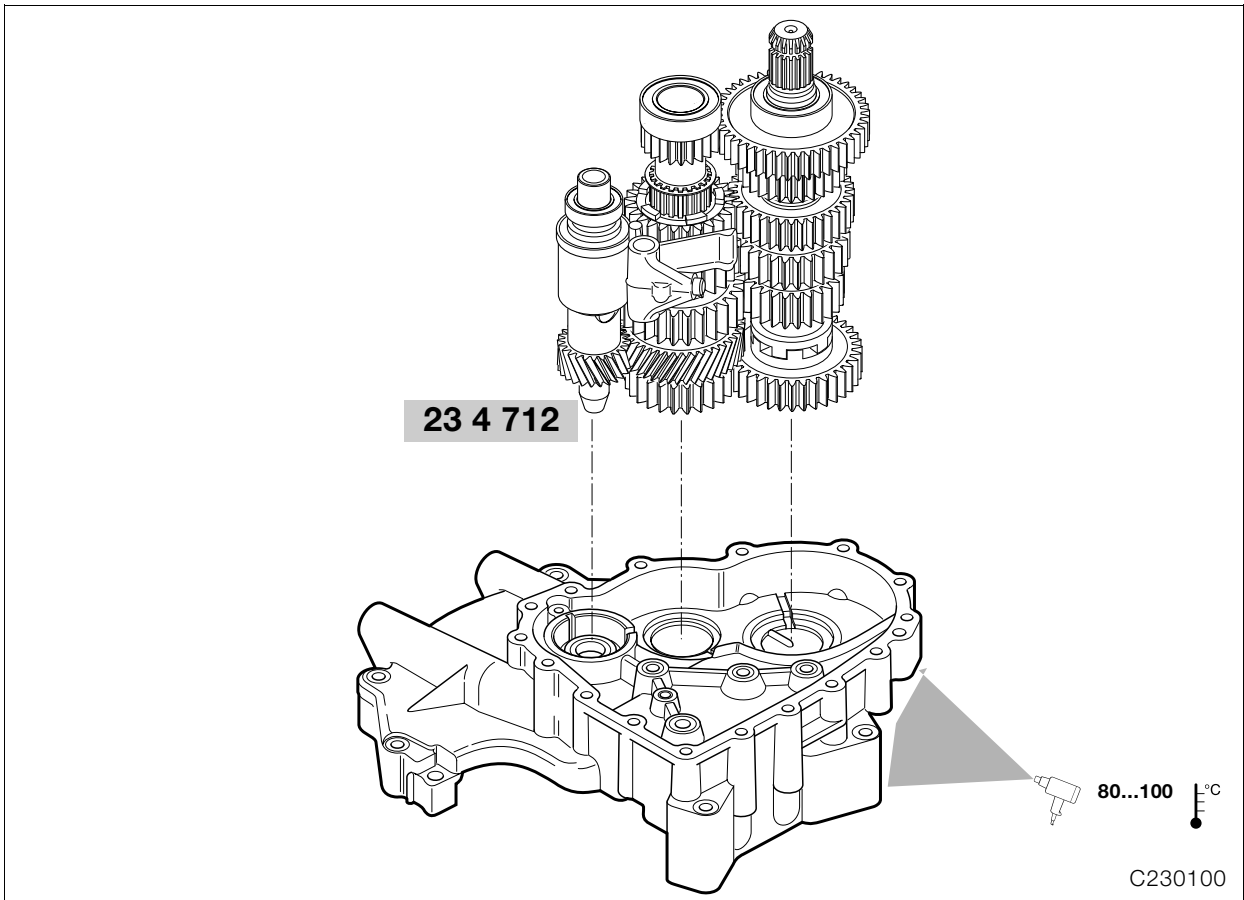

Assembling gearbox

Installing input, output and intermediate shaft

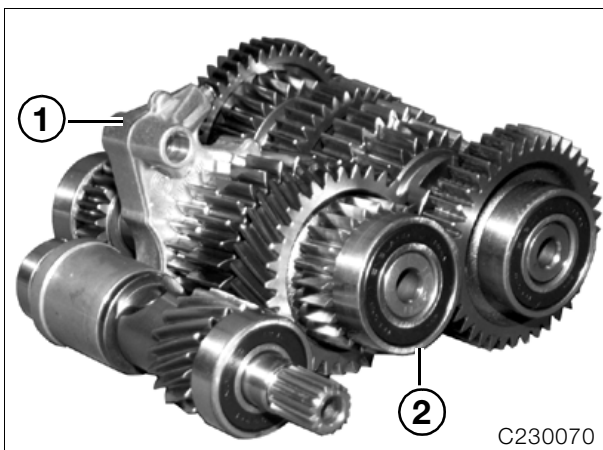

- Insert selector shaft (1) into intermediate shaft (2).

- Align input, output and intermediate shafts so that their gear teeth mesh and the selector fork is in the position illustrated.
- Push slip-over sleeve, **BMW No. 23 4 712**, on to the input shaft splines.



Note:

This is only necessary if the shaft sealing ring is installed.

- Heat the bearing points on the cover to 80 ... 100 °C (176 ... 212 °F).
- Insert the input, output and intermediate shafts together.



Caution:

Check that the gearbox shafts are correctly seated.

- Install the 1st/3rd gear and 2nd/4th gear selector forks.

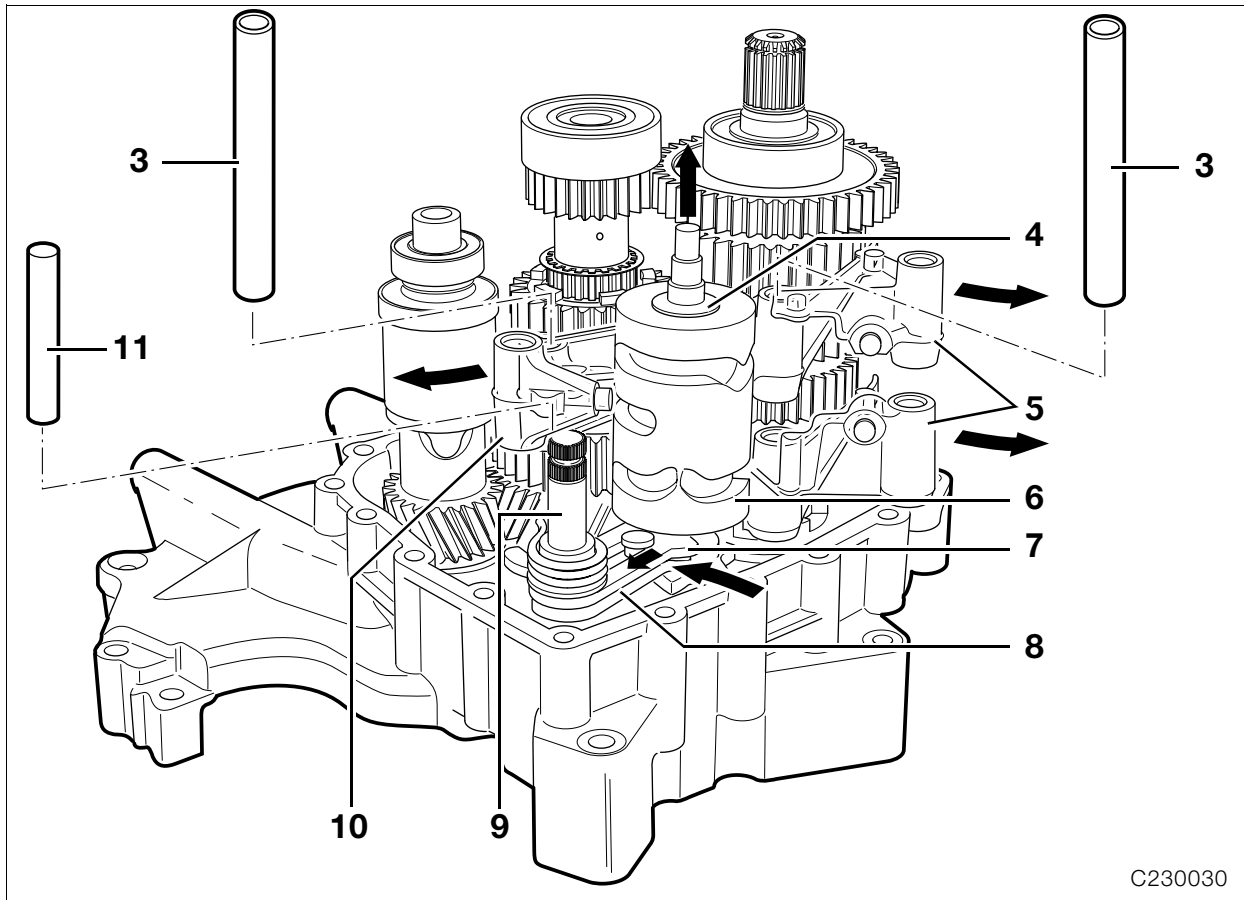

C230030

Installing selector shaft

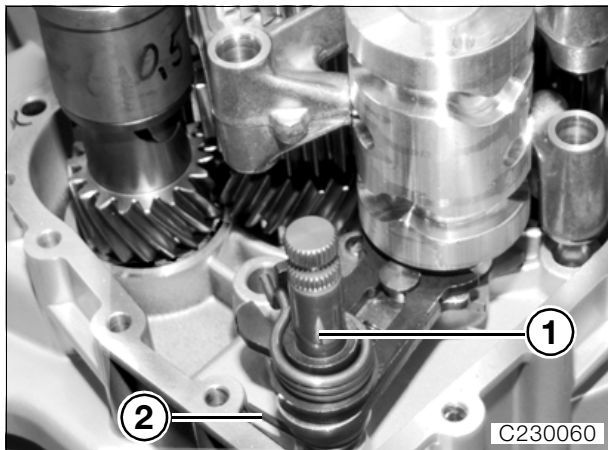

- Place a spacing washer of the determined thickness in position and install selector shaft (1).
- Engage torsion spring (2) in the housing.

Installing selector drum

- Place a spacing washer of the determined thickness and the input-side thrust washer on selector drum (6) and secure with a small amount of grease.
- Swing locking lever (8) out towards the edge of the cover and install the selector drum.
- Swing locking lever (8) towards selector drum (6) and engage it in position together with guide plate (7).
- Place shift forks (5, 10) in the guide tracks.
- Install selector shafts (3).
- Install locking pin (11).
- Place thrust washer (4) on the selector drum.



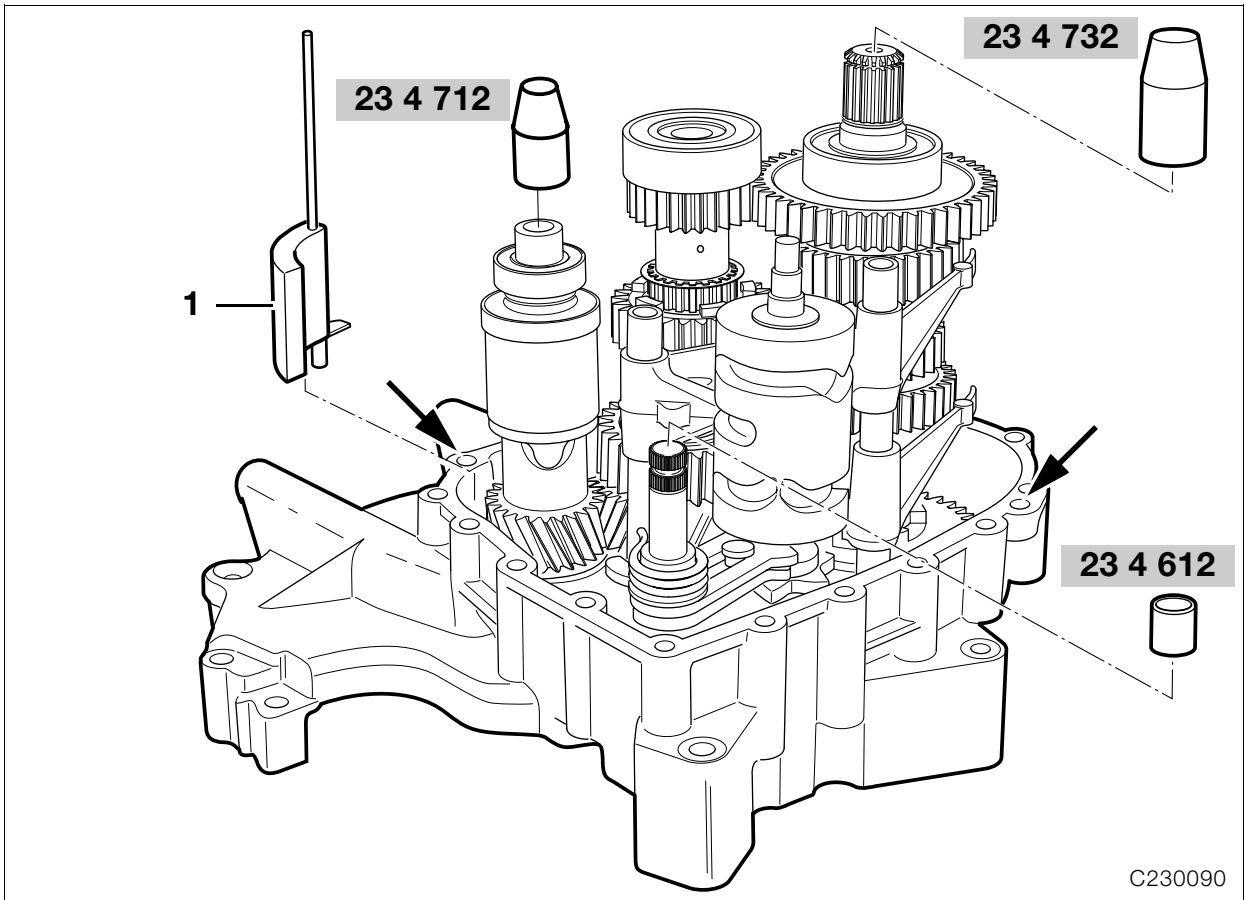

Assembling gearbox housing

- Install reamed pins (arrows) in cover.
- Install breather tube (1) in housing cover.



Caution:

The sealing faces must be free from oil or grease. The sealing material sets within 30 minutes; within this time, place the housing in position and screw it down.

- Using the metering device, apply **Loctite 5203** surface sealant to the cover joint face.
- Place slip-over sleeve, **BMW No. 23 4 732**, on the output shaft.
- Place slip-over sleeve, **BMW No. 23 4 712**, on the input shaft.
- Place slip-over sleeve, **BMW No. 23 4 612**, on the selector shaft.

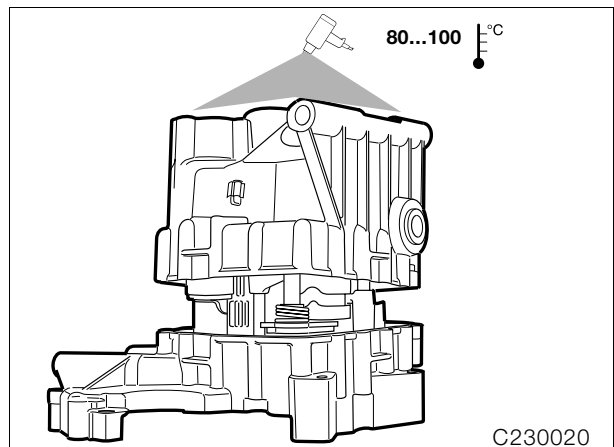

- Heat the bearing seats in the housing to 80 ... 100 °C (176 ... 212 °F) and place the housing on the cover.

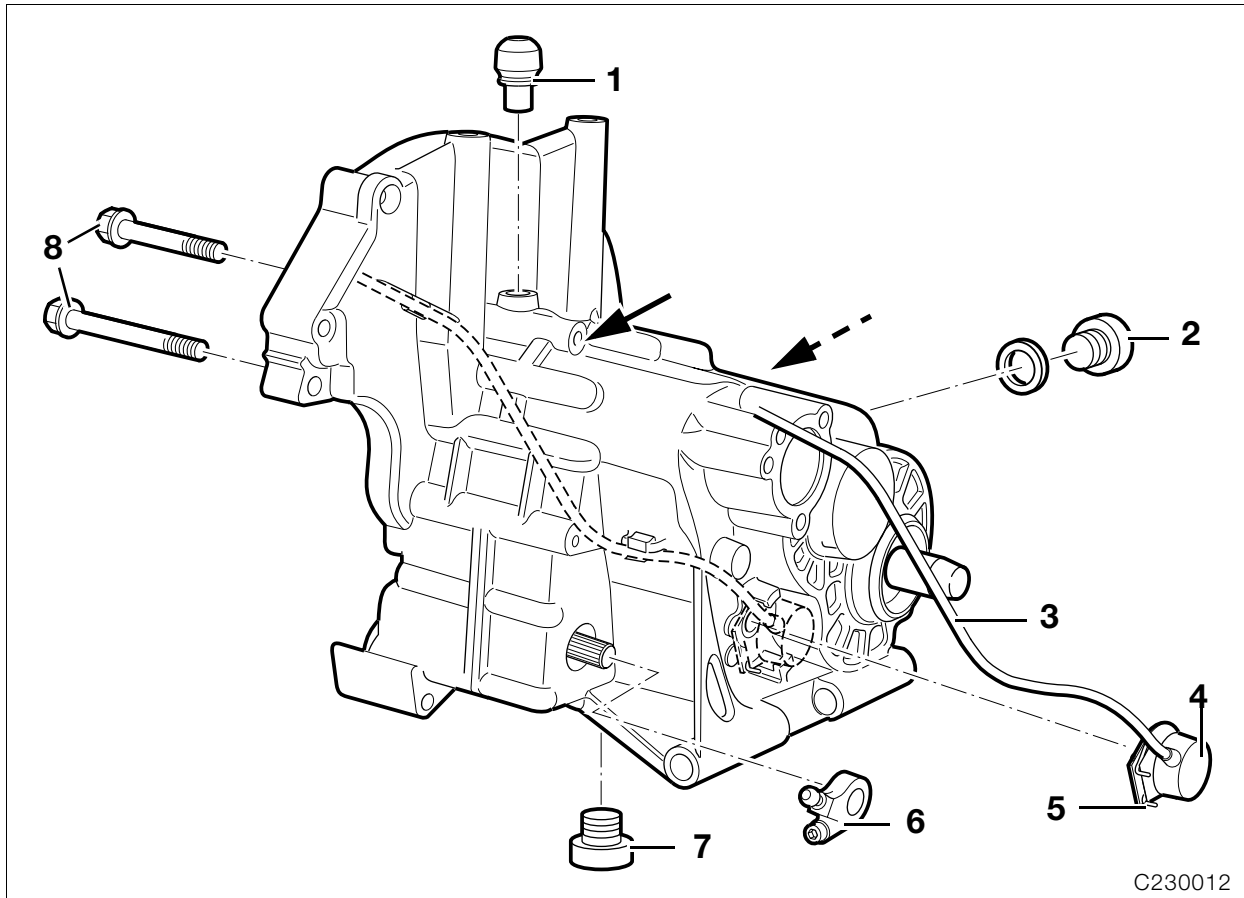

C230012

- Insert screws (8) and tighten in a crosswise pattern.
- Install neutral indicator (4) and clip wire (3) into position.
- Install breather (1).



Caution:

Clean metal particles off the magnet in drain plug (7).

- Insert oil drain plug (7).
- Insert oil filler and level check plug (2) with a new sealing ring.

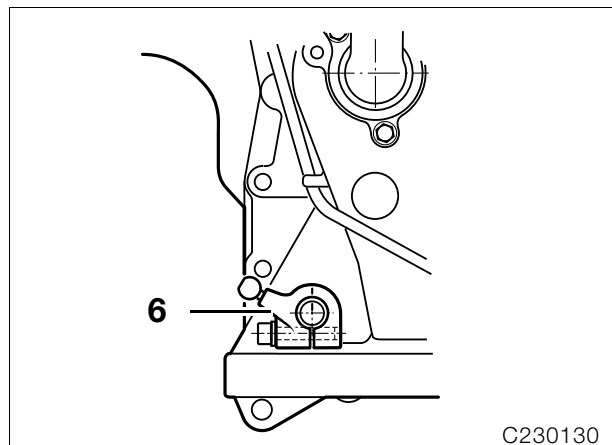

C230130

- Install shift lever (6) in the correct position.



Note:

In the correct position the mark on the selector lever (dot) is aligned with the mark on the selector shaft (line).

After assembling the gearbox, perform a functional check.

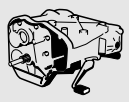

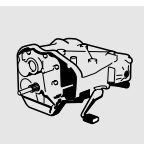

31 Front fork

Contents

Page

Technical data	3
Removing and installing telescopic fork	5
Removing and installing telescopic fork	5
Removing and installing fork bridge	5
Removing and installing pot-type joints	6
Removing and installing ball thrust bearing	7
Removing and installing slider tube bridge	8
Removing and installing ball joint	8
Checking friction at ball joint/ball thrust bearing	8
Assembly specification for telescopic fork:	9
Dismantling/reassembling telescopic fork	10
Dismantling telescopic fork	10
Assembling telescopic fork	10
Measuring telescopic fork	11
Check slider tube bridge	11
Checking runout of fixed tube	11
Removing and installing leading link	12
Dismantling/reassembling leading link	12
Removing and installing front suspension strut	12

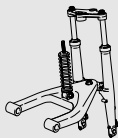



Technical data		R 850 C	R 1200 C
Front suspension			
Type		BMW Telelever with external suspension strut	
Telescopic fork			
Front wheel caster in normal-load position	mm (in)	86 (3.39)	
Steering lock angle	°	2 x 38	
Total suspension travel	mm (in)	144 (5.67)	
Fixed tube surface		Hard chrome plated	
Extl. dia. of fixed fork tubes	mm (in)	35.0 (1.38)	
Maximum permissible runout of fixed fork tube	mm (in)	0.4 (0.016)	
Telescopic fork oil – approved grades		BMW telescopic fork oil	
Fill quantity in each fork leg	l (Imp. pint/ US quart)	0.470 (0.8275/0.4966)	
Suspension strut			
Type		Suspension strut with coil spring and twin-tube, gas-filled shock absorber	

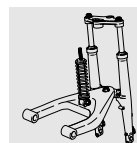



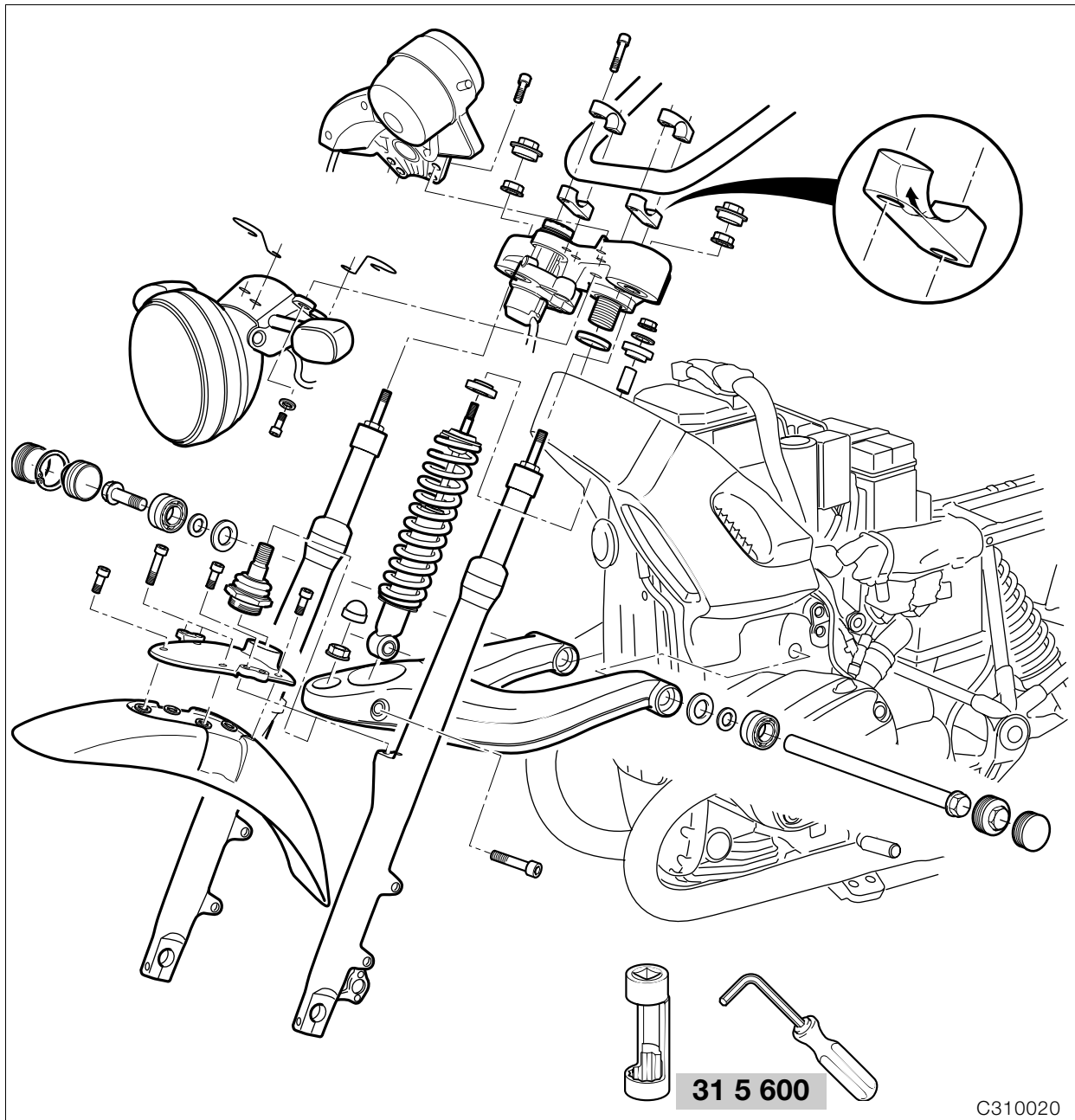

Removing and installing telescopic fork

Removing and installing telescopic fork

- Remove front wheel.
- Remove mudguard.
- **[ABS]** Detach sensor.
- Detach brake line retainer.
- Heat leading link mount at front to max. 120 °C (248 °F) and unscrew.
- Force off cap from fork bridge mount on frame with an M6 screw (thread length at least 25 mm/ 0.98 in).
- Unfasten fixed tube screw connection at fork bridge, preventing movement by holding hexagon on fixed tube.

Removing and installing fork bridge

- Unscrew fuel tank and pull to the rear.

- Separate the connecting plug for the ignition/steering lock in the central electrical equipment box.
- Detach the instrument holder.
- Detach the headlight holder.
- Detach handlebar from fork bridge.
- Force off cap from fork bridge mount on frame with an M6 screw (thread length at least 25 mm/ 0.98 in).
- Unfasten screw connection between fork bridge and frame.



Note:

Remove complete, since the threaded journal is a press fit in the ball thrust bearing.

- Remove fork bridge.
- Remove ignition/steering lock.

➔ Group 51



- Install by following the above work instructions in the reverse order.
- Using a socket wrench insert and internal hexagon, **BMW No. 31 5 600**, tighten the ball joint at the leading link.

⚠ Caution:

To prevent grease from escaping and the ingress of dirt, ensure that sleeve is correctly located on ball joint.

- **[ABS]** Check sensor gap and adjust if necessary.

ABS –

Sensor gap:..... 0.50...0.55 mm (0.019...0.021 in)



Tightening torque:

Screw connection between fork bridge and frame (clean thread + Loctite 243)..... 130 Nm
 Threaded connection between fork bridge and fixed tube (free from oil and grease)..... 35 Nm
 Handlebar at fork bridge
 (install the lower clamping block facing forwards (direction of arrow) and tighten the front clamp first)
 21 Nm
 Instrument holder at fork bridge 9 Nm
 Headlight holder at fork bridge 15 Nm

Removing and installing pot-type joints

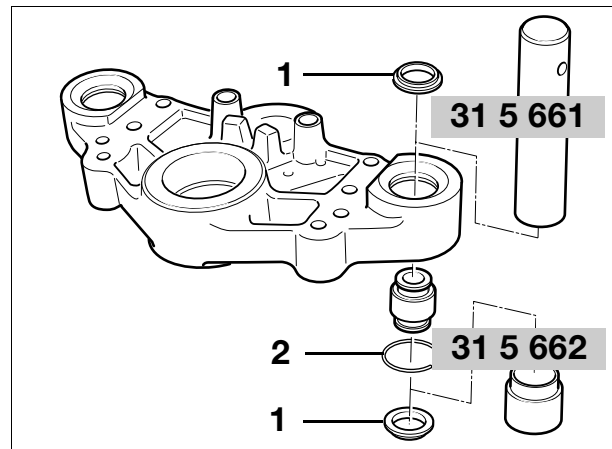

- Remove dust covers (1).
- Remove snap ring (2).
- Press out pot-type joint with pin, **BMW No. 31 5 661**, and bushing, **BMW No. 31 5 662**.

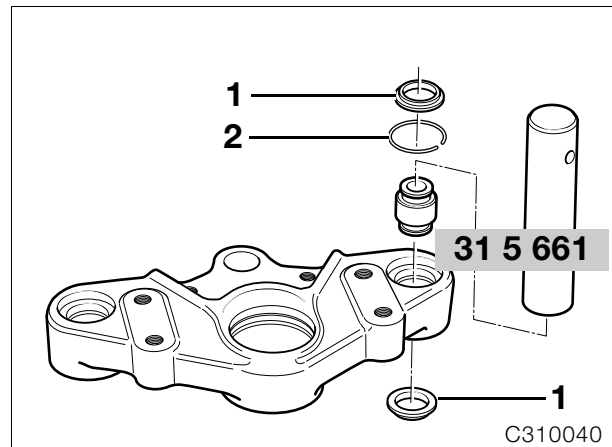

- Press the pot-type joint in with pin, **BMW No. 31 5 661**.
- Install snap ring (2).
- Install dust covers (1).



Removing and installing ball thrust bearing

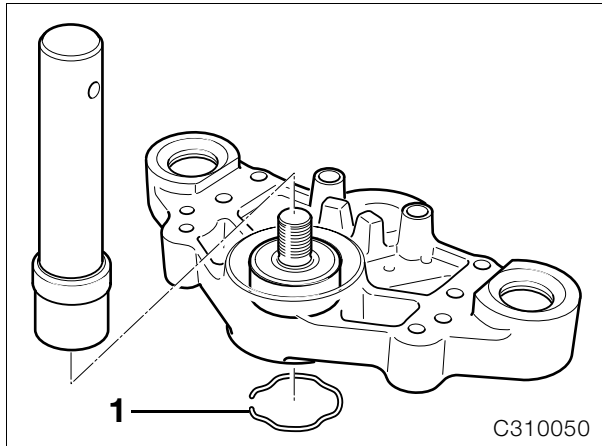

- Remove retaining ring (1).
- Heat fork bridge to 100 °C (212 °F).
- Remove ball thrust bearing, if necessary striking lightly with a plastic-faced hammer.

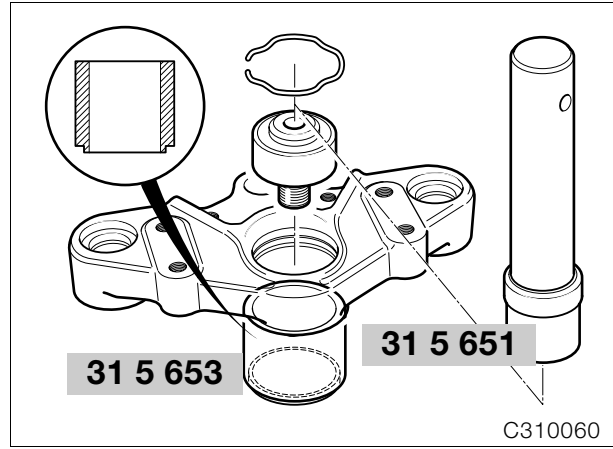

- Heat the fork bridge to 100 °C (212 °F) and press in the ball thrust bearing with pin, **BMW No. 31 5 651**, and bushing, **BMW No. 31 5 653**.
- Install retaining ring.

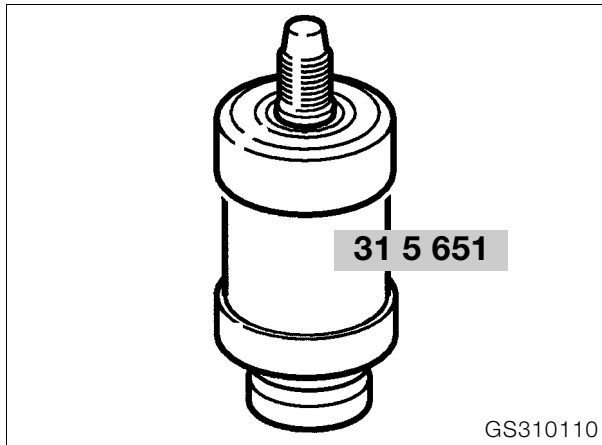

- Press out the threaded journal using a pin, **BMW No. 31 5 651**, as a support.

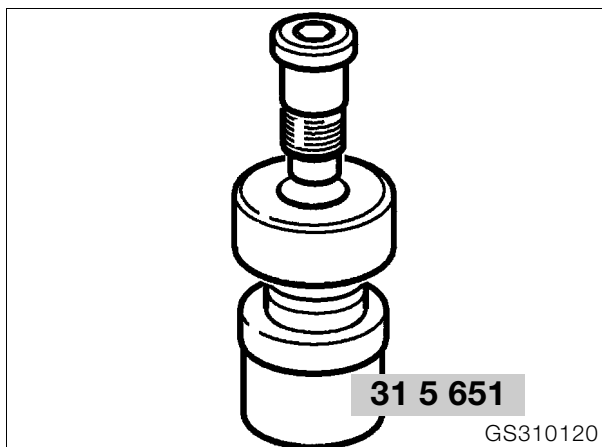

- Press the threaded journal into the ball thrust bearing using a pin, **BMW No. 31 5 651**, as a support.



Removing and installing slider tube bridge

- Removing the front mudguard

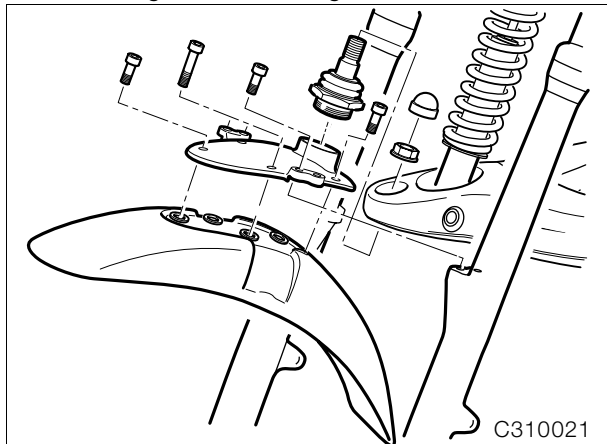

- Heat the ball joint mount on the leading link to max. 120 °C (248 °F) and detach it.
- Unscrew slider tube bridge.
- Install by following the above work instructions in the reverse order.
- Tighten the ball joint to the leading link using socket wrench insert and internal hexagon, **BMW No. 31 5 600**.



Caution:

Comply with assembly instructions for telescopic fork.



Tightening torque:

Bridge to fork slider
(clean thread + Loctite 243)..... 22 Nm
Ball joint to leading link
(use a new nut or clean
thread + Loctite 2701)..... 130 Nm

Removing and installing ball joint

- Mount the slider tube bridge in retaining fixture, **BMW No. 31 5 620**.
- Unscrew/tighten ball joint with 46 mm (1.81 in) socket wrench insert, **BMW No. 31 5 630**, in conjunction with protective ring, **BMW No. 31 5 632**.



Tightening torque:

Ball joint to slider tube bridge
(apply Never Seez to thread) 230 Nm

Checking friction at ball joint/ball thrust bearing

- Motorcycle raised on auxiliary stand, **BMW No. 00 1 550**; front wheel must be clear of ground.
- Measure the breakaway moment to left and right from the central position of the handlebar using friction meter, **BMW No. 00 2 570**.



Note:

To determine the friction value, increase torque very slowly.

Friction value:

Measure at room temperature (above 20 °C/68 °F)
Nominal value: 1.0...4.0 Nm

Assembly specification for telescopic fork:



Caution:

To ensure that the fork is installed without trapped stresses, observe the following instructions and the specified working sequence precisely.

- The front suspension strut is removed.



Caution:

Protect painted parts from scratching: apply adhesive masking tape if necessary.

- Bolt fork bridge to frame.



Tightening torque:

Threaded journal to frame (clean thread + Loctite 243)..... 130 Nm

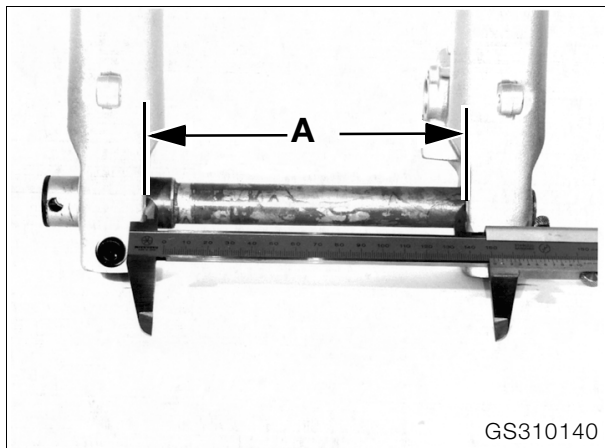

GS310140

- Pre-assemble fork legs with quick-release axle/ adjust distance A.

Distance A:..... 165 ±0.5 mm (6.50 ±0.02 in)



Tightening torque:

Quick-release axle clamps 22 Nm



Note:

If the quick-release axle was not removed, for instance when only the fork slider tube bridge was removed/installed, the above work stage is omitted.

- Secure slider tube bridge/do not tighten to specified torque at this point.
- Screw slider tube bridge to leading link.



Tightening torque:

Leading link at ball joint (clean thread + Loctite 2701)..... 130 Nm

- Using a strap or similar, pull fork towards frame until the fully retracted fixed tubes only need to be pulled out slightly to secure them to the fork bridge.
- Secure fixed tubes to the fork bridge.



Tightening torque:

Screw connection between fixed tube and fork bridge (free from oil and grease) 35 Nm

- Tighten down slider tube bridge.



Tightening torque:

Bridge to fork slider (clean thread + Loctite 243)..... 22 Nm

- Check that the system moves freely by compressing and extending the suspension (but without the suspension strut) in the straight-ahead and left/right steering lock positions.
- Remove quick-release axle.



Caution:

When being reassembled, the quick-release axle must well aligned; it should be possible to install it by rotating it slightly.

- Install suspension strut.



Tightening torque:

Spring strut to frame 40 Nm
Spring strut to leading link..... 40 Nm

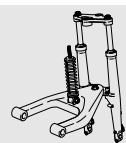

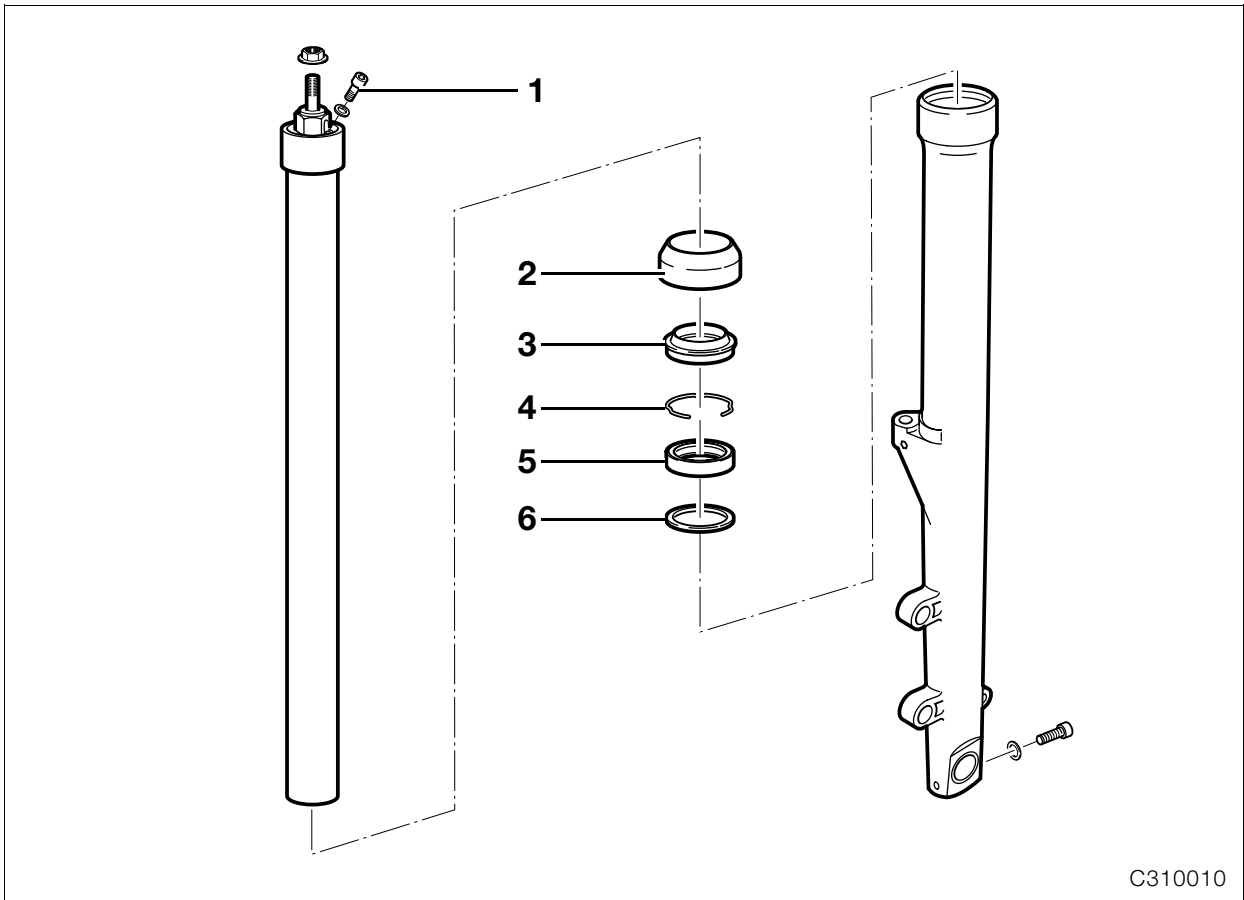

C310010

Dismantling/reassembling telescopic fork

Dismantling telescopic fork

- Remove bleed screw (1).
- Pull out fixed tube/drain oil.
- Carefully press off chromium plated cap (2) at groove.
- Lever out the dust sleeve (3).



Caution:

Do not damage fork slider tube.

- Remove retaining ring (4).
- Lever out shaft seal (5).
- Remove washer (6).

Assembling telescopic fork

- Fill with oil.

Quality per

fixed tube 0.470 l (0.82 Imp. pint/0.49 US quart)

Oil grade

in telescopic fork:.....BMW telescopic fork oil



Note:

No oil changes required during services: unit is maintenance-free.

- Install fixed tube.
- Install washer (6).
- Oil the shaft seal slightly and push it on as far as possible (to stop on slider tube) by striking it lightly with drift, **BMW No. 31 5 610**, and reducing adapter, **BMW No. 31 5 613**.
- Install retaining ring and dust cover.
- Attach the chromium plated cap.
- Insert bleed screw (1).
- Bleed telescopic fork in no-load position.



Tightening torque:

Screw plug to fixed fork tube press-fit - do not remove!

Measuring telescopic fork



Caution:

After an accident, always examine the telescopic fork for cracks and signs of damage.

Check slider tube bridge

- Check that the slider tube bridge is flat.
-



Caution:

Renew slider tube bridge if distorted.

Checking runout of fixed tube

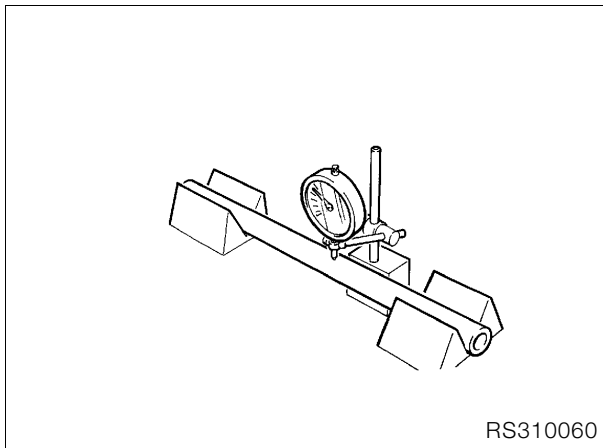

- Place both ends of fixed tube in V-blocks.
 - Rotate fixed tube slowly and check with dial gauge while doing so.
-



Caution:

Do not straighten distorted fixed tubes: always renew them.

Permissible runout: 0.4 mm (0.016 in)



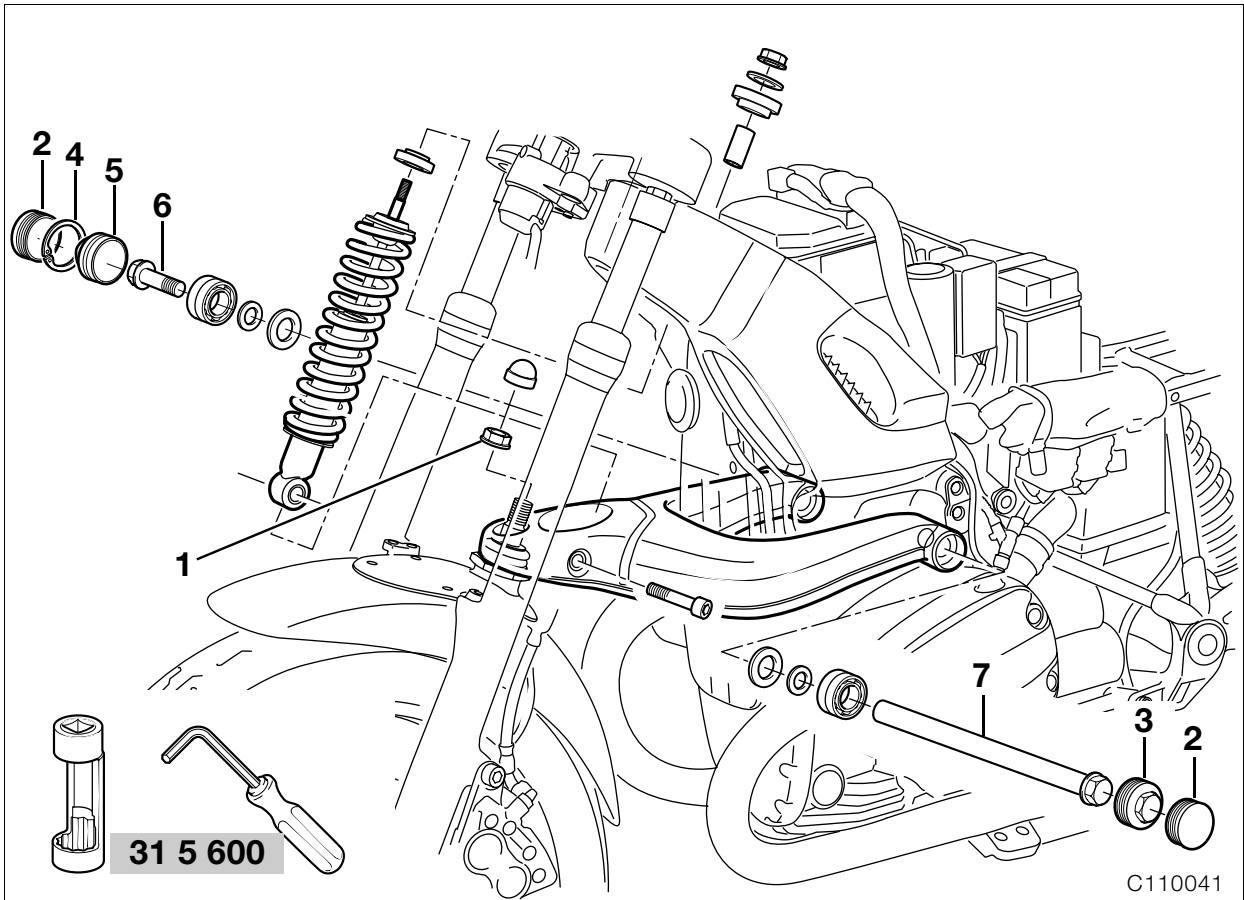

Removing and installing leading link

- Unscrew bottom of spring strut.
- Heat ball joint mount (1) at leading link to max. 120 °C (248 °F) and detach it.
- Remove covers (2) from leading link pivots.
- Remove left screw cap (3).
- Remove right retaining ring (4) and retaining cap (5).
- Take out right screw (6) and remove shaft (7) by pulling to the left.
- Pull telescopic fork forwards and carefully remove leading link by pulling forwards.

⚠ Caution:

Protect parts against scratching; mask them off if necessary.

- Install by following the above work instructions in the reverse order.
- Apply a light coating of grease to the axle before installing.
- Tighten the ball joint at the leading link with the socket wrench insert and internal hexagon, **BMW No. 31 5 600**.

🔧 Tightening torque:

Right leading link to engine	73 Nm
Left screw cap (coat thread lightly with Never Seez).....	42 Nm
Leading link to ball joint (use a new nut or clean thread + Loctite 2701).....	130 Nm
Spring strut to leading link.....	40 Nm

Dismantling/reassembling leading link

- Press the bearing out/in with a suitable drift.

⚠ Caution:

Always install bearing by applying pressure to outer race.

Removing and installing front suspension strut

- Detach and pull back the fuel tank.

⚠ Caution:

Protect parts against scratching; mask off if necessary.

🔧 Tightening torque:

Spring strut to frame	40 Nm
Spring strut to leading link.....	40 Nm

32 Steering

Contents

Page

Technical data	3
Removing and installing left handlebar fitting	5
Removing and installing right handlebar fitting	6
Removing and installing handlebar	7
Removing/installing throttle cable	8

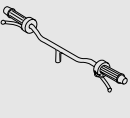

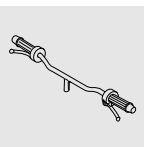

Technical data	R 850 C	R 1200 C
Steering lock angle	° 2 x 38	
Steering head tube dia.	mm (in) 25 (0.98)	
Width over mirrors	mm (in) 1050 (41.34)	

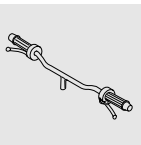

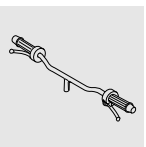

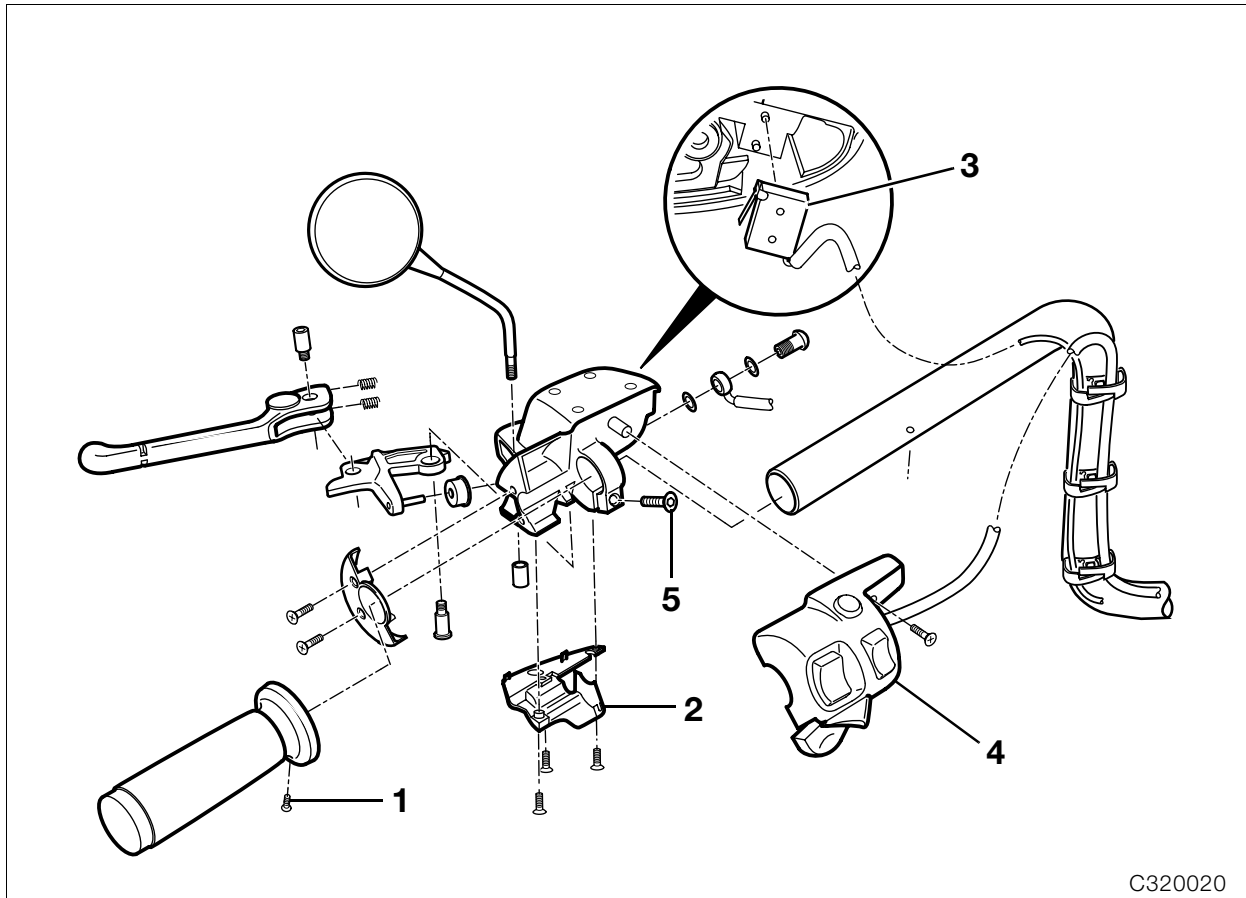

C320020

Removing and installing left handlebar fitting

- Detach mirror.
- Loosen screw (1) for handlebar grip and pull off the grip.
- Detach lower section (2) at handlebar fitting.
- Pull off clutch switch (3).
- Detach combined switch (4).
- Drain the clutch operating system.



Caution:

Do not allow brake fluid to come into contact with painted parts of the motorcycle, because brake fluid destroys paint.

- Detach the clutch line.
- Loosen the retaining screw (5) for the clutch fitting and pull the fitting off.
- Unscrew fuel tank and pull to the rear.
- Take off the central electrical equipment box cover.
- Pull off the combined switch plug.
- Pull off the clutch switch plug.
- Install by following the above work instructions in the reverse order.
- Align the clamp joint line with the punch mark on the handlebar.
- Fill/bleed the clutch operating system.



Tightening torque:

Clutch lever fitting to handlebar 8 Nm
 Clutch line to clutch lever fitting 18 Nm

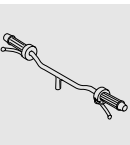

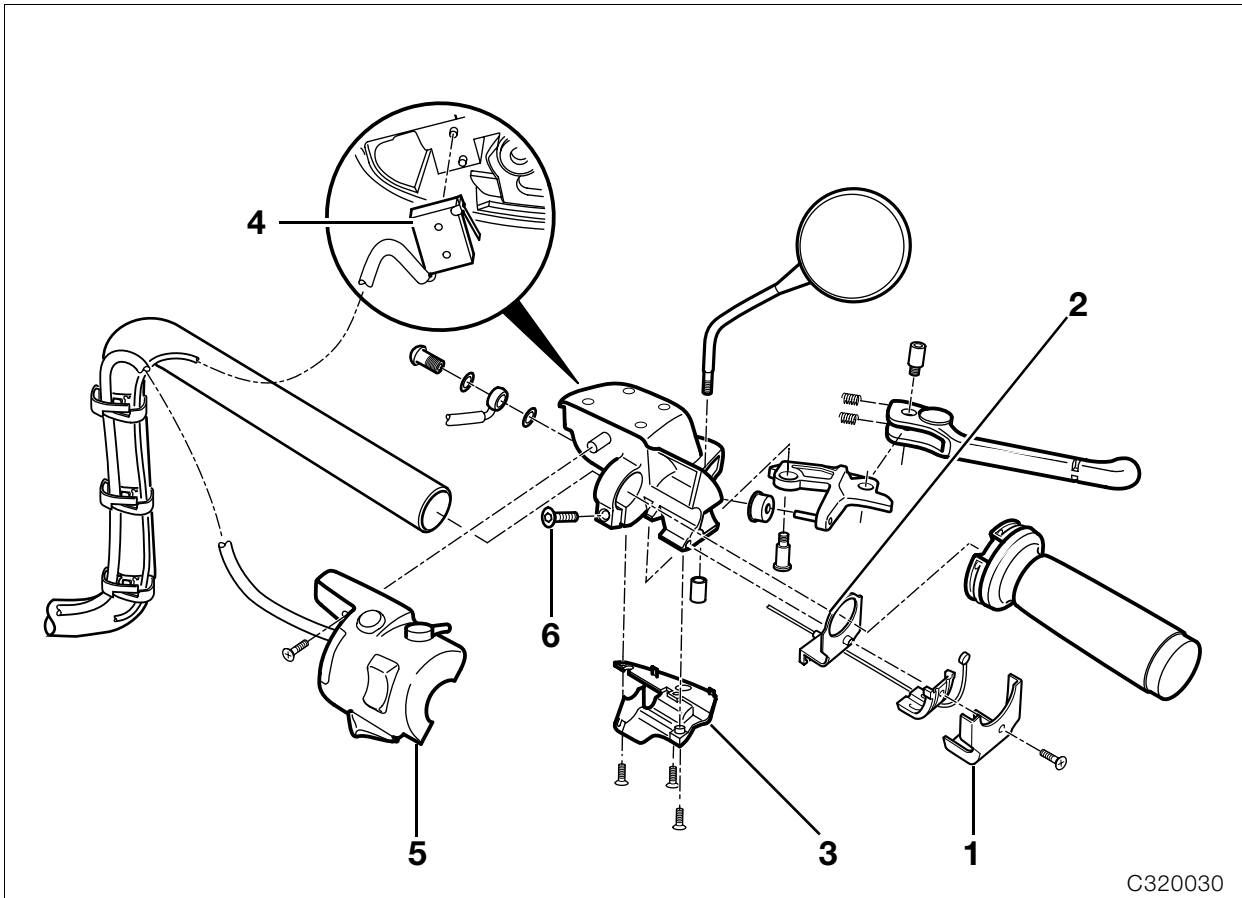

C320030

Removing and installing right handlebar fitting



Tightening torque:

Brake lever fitting to handlebar.....	8 Nm
Brake hose to brake lever fitting.....	18 Nm

- Detach the mirror.
- Remove throttle twistgrip cover (1).
- Take out the wire cable adjusting screw (2) and disconnect the wire cable.
- Pull off the throttle twistgrip.
- Remove the lower section (3) of the brake lever fitting.
- Pull off the brake light switch (4).
- Detach the combined switch (5).
- Drain fluid from brake system.



Caution:

Do not allow brake fluid to come into contact with painted parts of the motorcycle, because brake fluid destroys paint.

- Detach the brake line.
- Loosen the retaining screw for the brake lever fitting (6) and pull the fitting off.
- Unscrew fuel tank and pull to the rear.
- Take off the central electrical equipment box cover.
- Pull off the combined switch plug.
- Pull off the brake light switch plug.
- Install by following the above work instructions in the reverse order.
- Align the clamp joint line with the punch mark on the handlebar.
- Fill/bleed the brake system.

Removing and installing handlebar

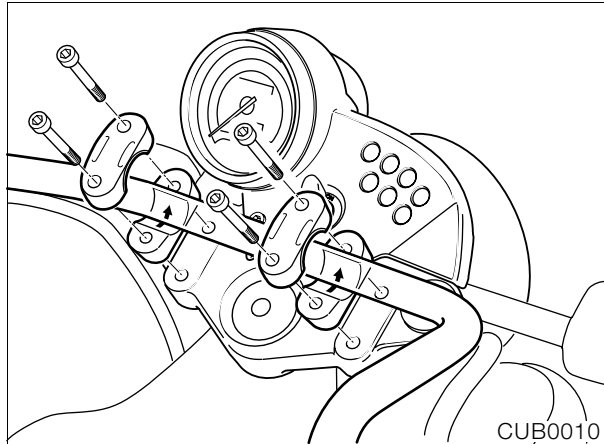

- Remove left/right handlebar fittings.
- Remove handlebar.
- Install in the reverse order of work.
- Install the lower clamp block with the arrow pointing forwards.
- Tighten the front clamp block first.



Note:

The clamp is higher at the front.



Caution:

Ensure that brake hoses are correctly located.



Tightening torque:

Clamp to fork bridge 21 Nm

Handlebar adjusting dimension:

Standard/Police

Distance from turn indicator switch to fuel tank with handlebar at full left or right lock
..... variable, 30...50 mm (1.18...1.97 in)

Optional extra/Easy Rider

Distance from turn indicator switch to fuel tank with handlebar at full left or right lock
..... 30 mm (1.18 in)

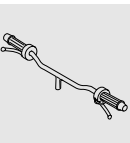

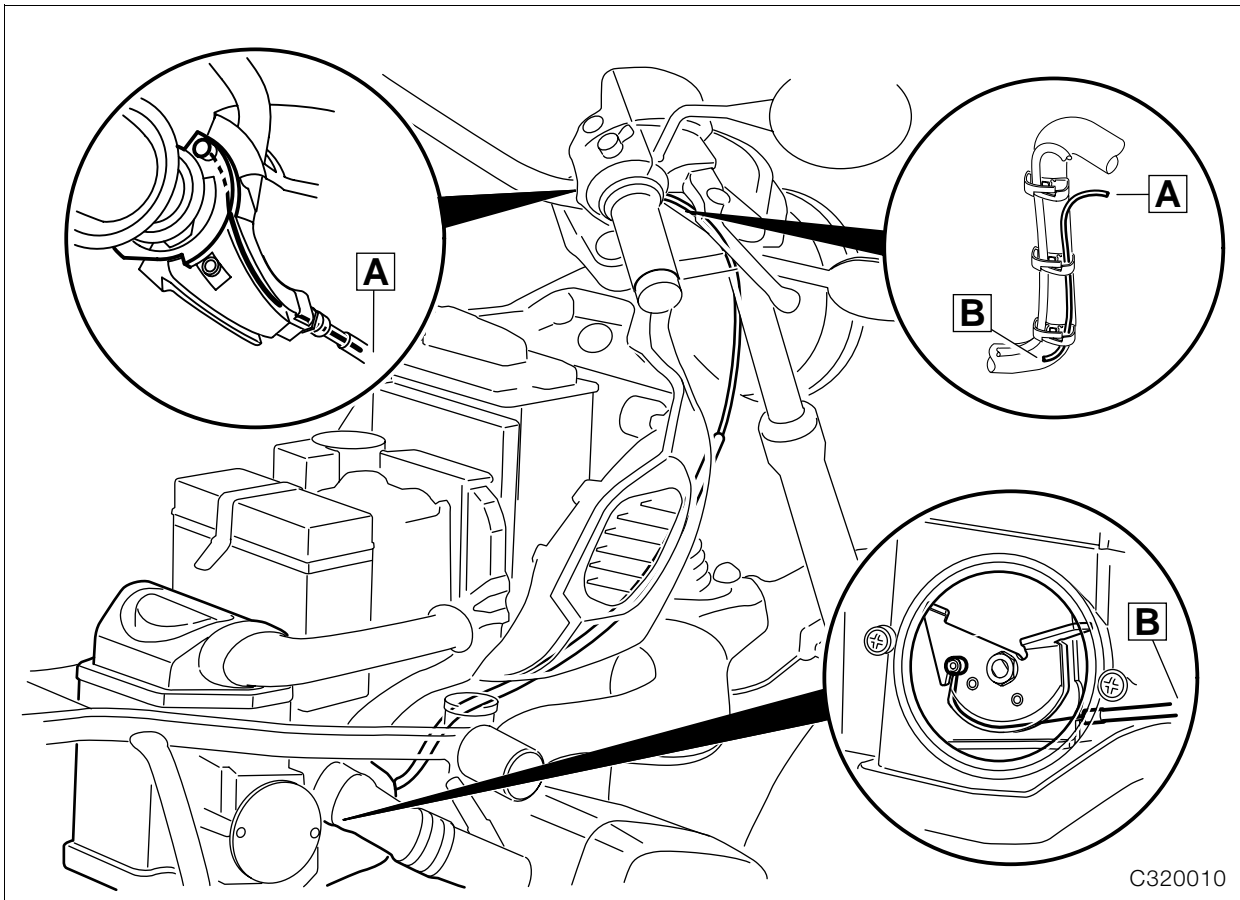

C320010

Removing/installing throttle cable

- Unscrew fuel tank and pull to the rear.
- Remove wire cable cover at fitting and disconnect the wire cable.
- Remove cover at air cleaner housing.
- Disconnect/remove the wire cable.



Note:

If necessary, press the nipple out from the rear with a wire hook.

- Install by following the above work instructions in the reverse order.



Caution:

Install wire cable without kinking.

- Adjust wire cable.
- ➡See Group 00

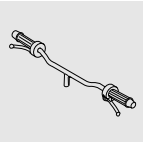

33 Rear wheel drive

Contents

Page

Technical data	3
Removing, dismantling, reassembling and installing rear wheel drive	5
Removing rear wheel drive	5
Removing input bevel pinion	5
Disassembling input bevel pinion	7
Removing needle roller bearing for input bevel pinion	7
Installing needle roller bearing for input bevel pinion	7
Assembling input bevel pinion	8
Installing input bevel pinion	9
Removing and dismantling the crown wheel	10
Assembling/installing crown wheel	11
Checking/adjusting backlash	12
Checking tooth contact pattern	13
Shimming housing cover	14
Installing housing cover	14
Installing splined element	14
Removing/installing rear swinging fork	15
Removing rear swinging arm	15
Removing and installing taper roller bearing	16
Removing and installing flexible gaiter	16
Removing drive shaft	16
Checking universal joint for wear	16
Installing drive shaft	16
Installing rear swinging arm	17
Installing rear wheel drive	18
Removing and installing suspension strut	19

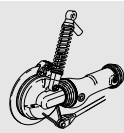

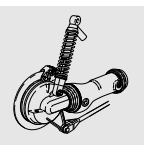

Technical data	R850 C	R 1200 C
Rear wheel drive		
Gear tooth pattern	Klingelnberg-Paloid spiral bevel	
Gear ratios	2.75 : 1	2.54 : 1
Number of teeth	33 : 12	33 : 13
Backlash	mm (in) 0.07...0.16 (0.0027...0.0063)	
Taper roller bearing preload	mm (in) 0.05...0.1 (0.0020...0.0039)	
Oil grades	Brand-name hypoid gear oil, SAE 90 GL 5	
Filling capacity	Initial filling up to lower edge of thread in oil filler hole I (Imp. pint/ US quart) app. 0.20 (0.35/0.21) During oil changes up to lower edge of thread in oil filler hole I (Imp. pint/ US quart) app. 0.18 (0.32/0.19)	
Drive shaft		
Layout	Two-piece shaft with universal joints at each end, central sliding joint and integral torsional vibration damper, enclosed in swinging arm	
Swinging arm		
Swinging arm length	mm (in)	611.75 (24.09) (from arm pivot point to centre of rear axle)
Rear suspension		
Suspension strut	Coil spring and single-tube, gas-filled shock absorber with seven spring preload settings	
Suspension travel	mm (in)	100 (3.94)

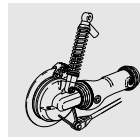

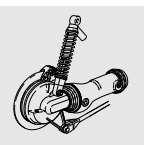

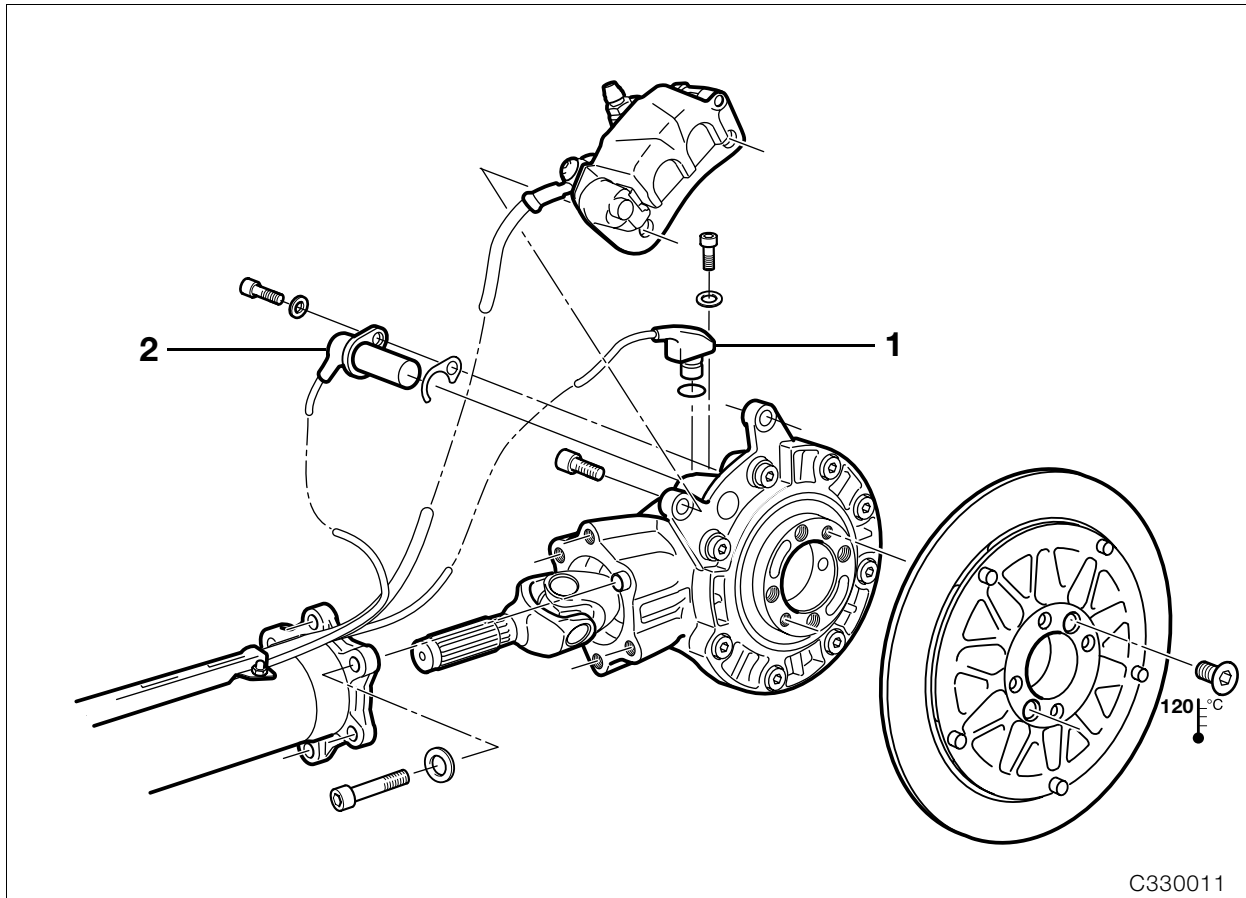

Removing, dismantling, reassembling and installing rear wheel drive

Removing input bevel pinion

Removing rear wheel drive

- Raise the motorcycle with the auxiliary stand, **BMW No. 00 1 550**.
- Drain the oil.
- Detach the brake caliper and secure it to the rear frame with a cable strap.
- Remove sensor (1) for the speedometer signal.
- Remove ABS sensor (2).
- Remove rear wheel.
- Heat the brake disc retaining screws to 120 °C (248 °F).



Note:

Mark the position of the brake disc.
The sensor gap setting remains unchanged.

- Detach the rear wheel drive and pull it off the drive shaft.

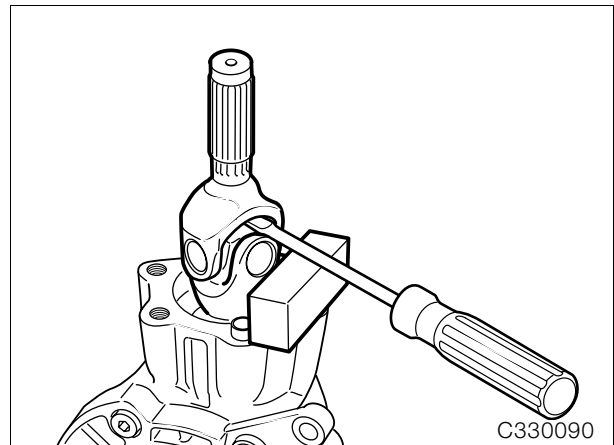

- Press out splined section of shaft.
- If necessary, remove/install circlip.

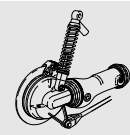

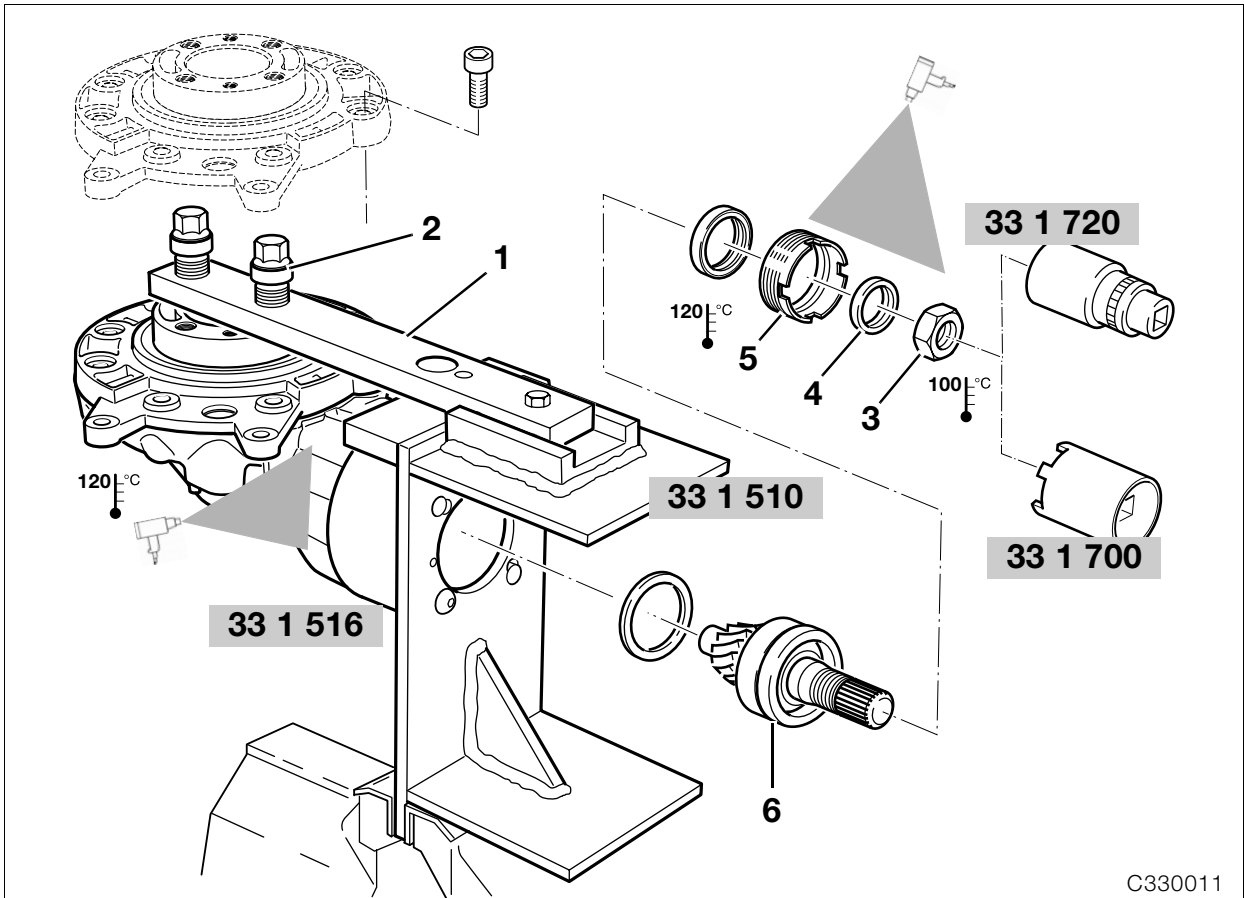

C330011

- Bolt the rear wheel drive to the retaining fixture, **BMW No. 33 1 510/511.**
- Bolt the locking arm (1) to the retaining fixture.
- Screw threaded bushings (2) down on to the rear wheel drive and secure them with the wheel studs.
- Heat hex nut (3) at the input bevel pinion to 100 °C (212 °F) and unscrew with 36 mm (1.42 in) socket wrench insert and reducing ring, **BMW No. 33 1 720.**



Note:

If necessary, use cross-handle with two tubular extensions.

- Pull off thrust ring (4).
 - Heat the housing to max. 120 °C (248 °F) and unscrew threaded ring (5) with pin wrench, **BMW No. 33 1 700.**
 - To remove the input bevel pinion (6), remove the crown wheel.
- ⇒ See "Removing crown wheel"
- Heat the bearing seat to max. 120 °C (248 °F).
 - Using an aluminium drift, carefully force the input bevel pinion outwards and remove it.

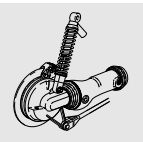

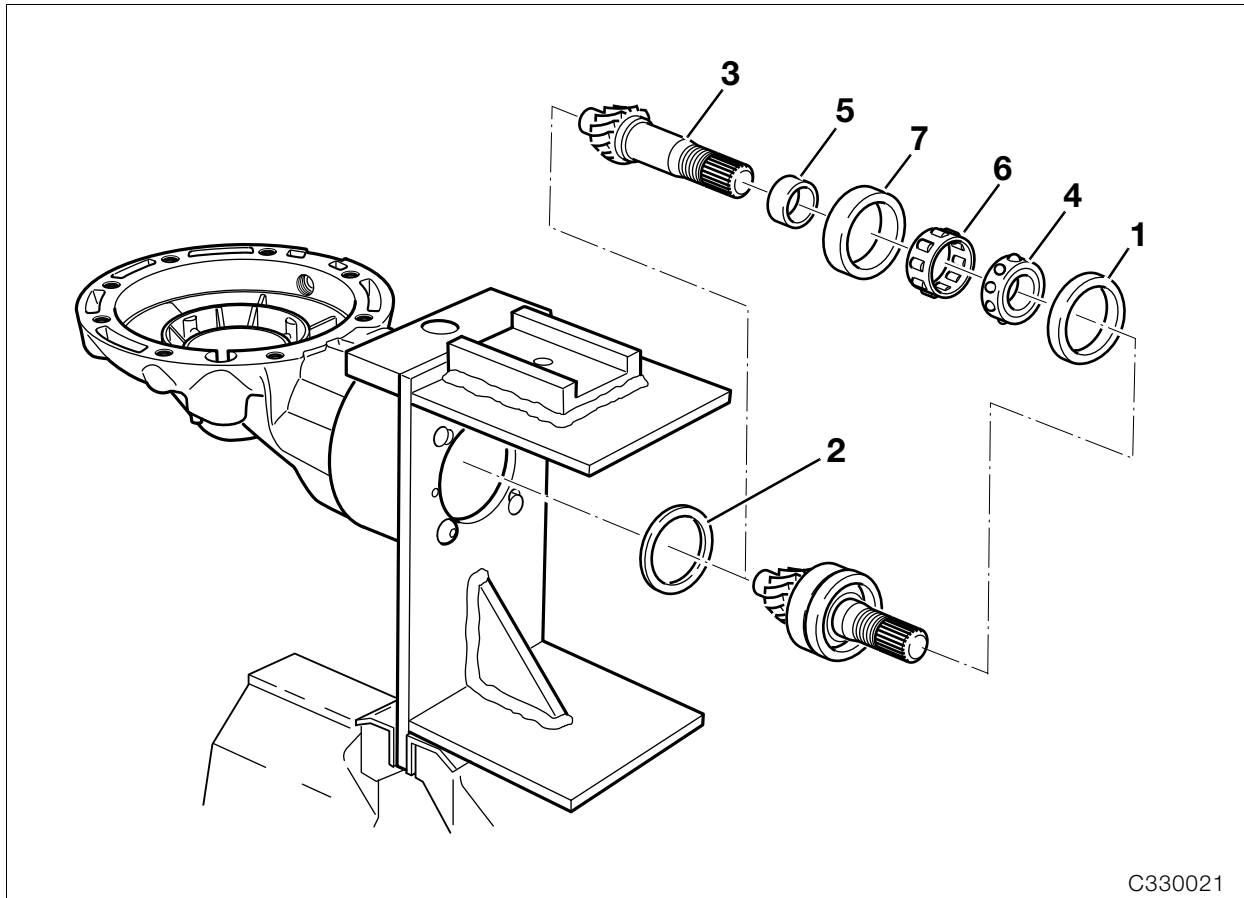

C330021

Disassembling input bevel pinion

- Remove outer bearing race (1).
- Pull spacer ring (2) out of housing.
- Clamp input bevel pinion (3) into vice with protective jaws (splines facing upwards).

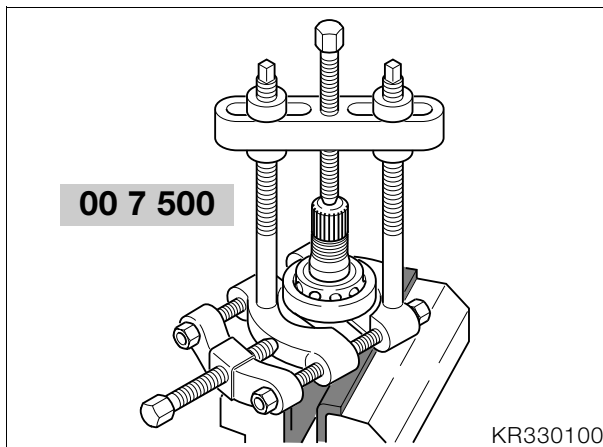

- Using puller, **BMW No. 00 7 500**, pull off both bearings at the same time.
- Take off ball thrust bearing (4), inner race (5), roller bearing cage (6) and outer race (7).

Removing needle roller bearing for input bevel pinion

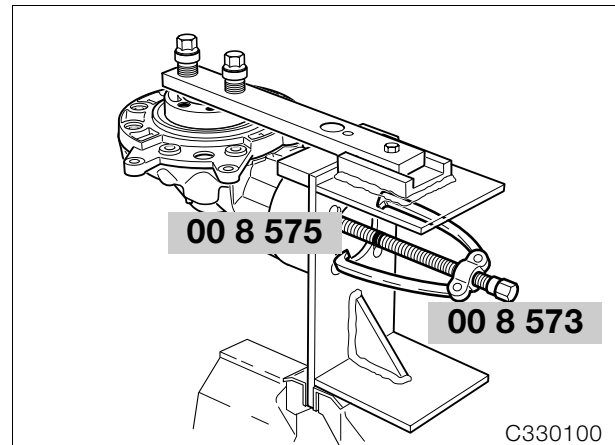

- Heat the housing to 130 °C (266 °F).
- Pull out the outer race of the needle roller bearing with puller, **BMW No. 00 8 573**, and threaded spindle extension, **BMW No. 00 8 575**.

Installing needle roller bearing for input bevel pinion

- Heat the needle roller bearing seat to 100 °C (212 °F).
- Press in needle roller bearing using drift or the input bevel pinion.

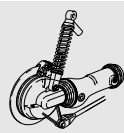

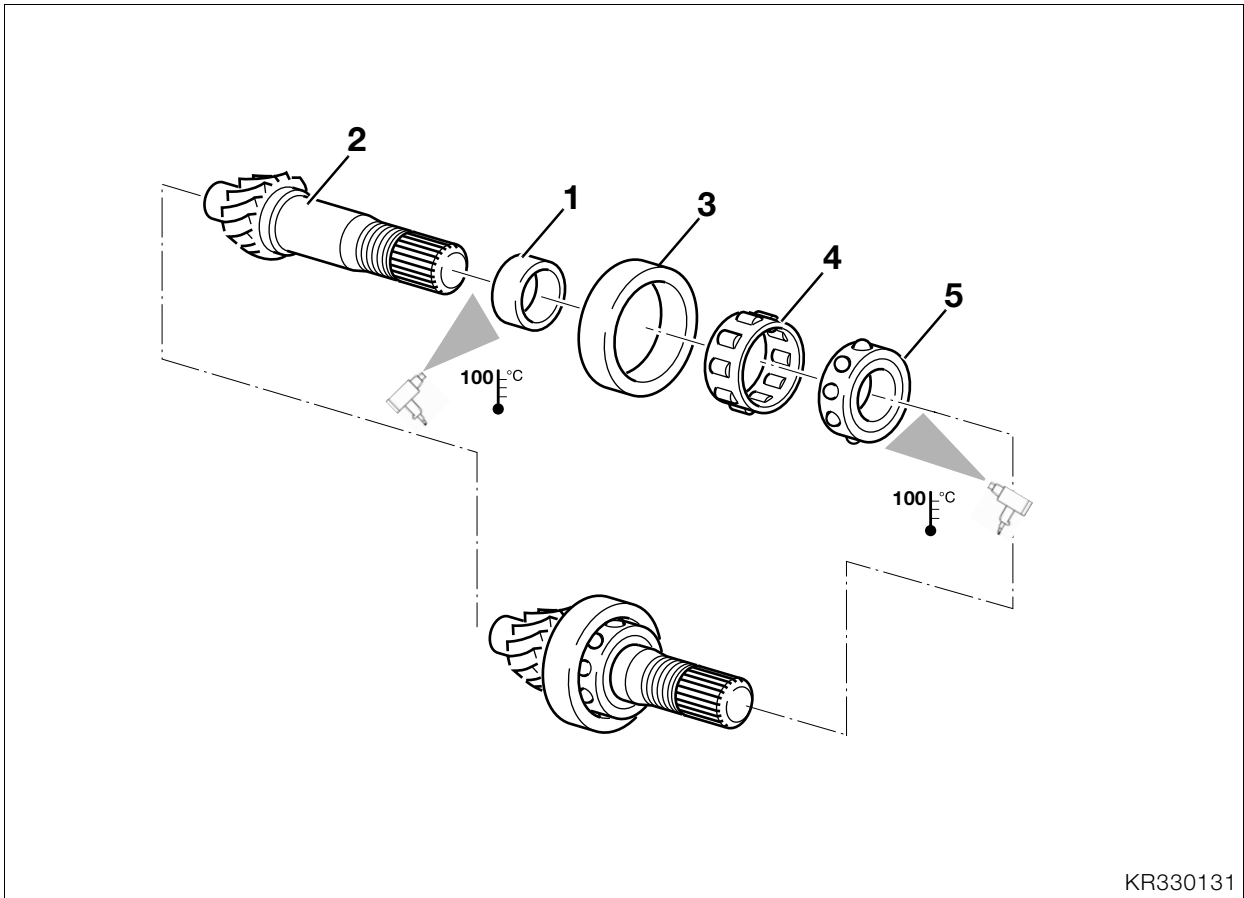

KR330131

Assembling input bevel pinion

- Heat the inner race (1) to 100 °C (212 °F) and push onto input bevel pinion (2) as far as the stop.
- Push the outer race (3) together with the roller cage (4) on to the inner race.
- Heat ball thrust bearing (5) to 100 °C (212 °F) and push fully on to input bevel pinion.
- Allow input bevel pinion to cool down.

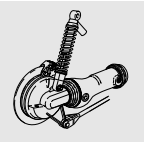

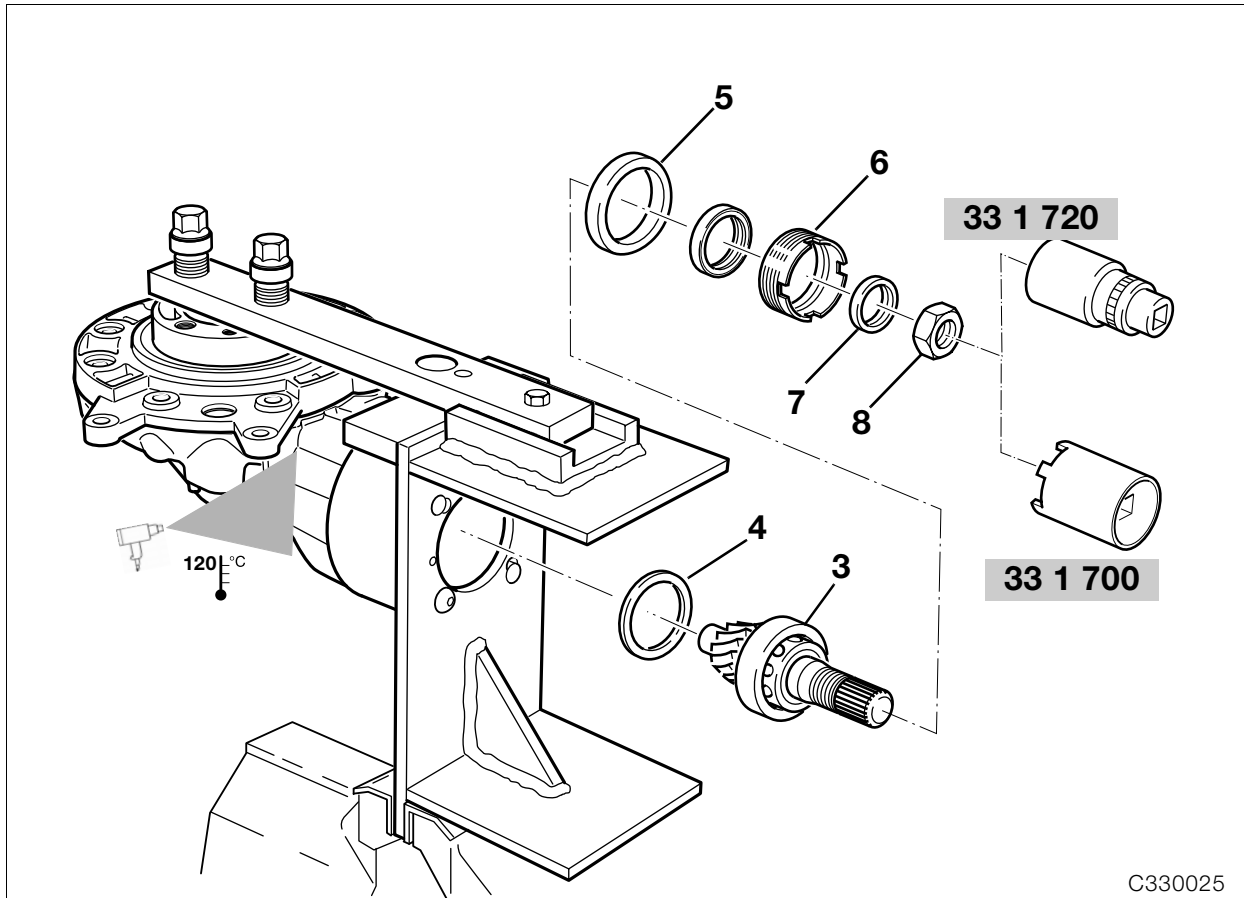

Installing input bevel pinion

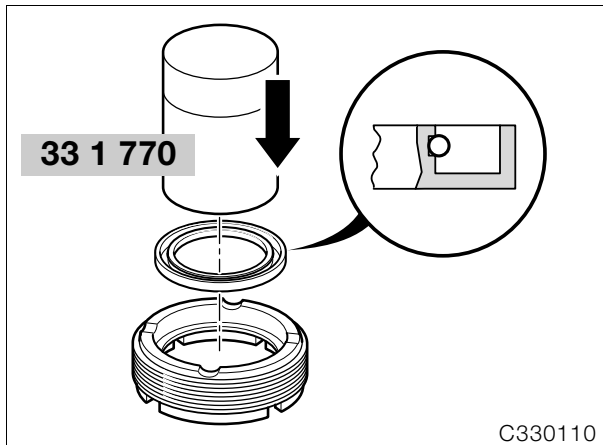

- Lightly oil the sealing ring at the sealing lip and round the outer edge.
- Press/drive sealing ring (1) with drift, **BMW No. 33 1 770**, and handle, **BMW No. 00 5 550**, into threaded ring (2).
- Heat the housing to 120 °C (248 °F).
- Insert the input bevel pinion (3) complete with spacing washer (4).
- Insert outer race (5).
- Coat threaded ring (6) with **Hylomar SQ 32 M**.
- Tighten threaded ring with pin wrench, **BMW No. 33 1 700**.
- Place thrust ring (7) in position.



Note:

Ensure that the lip of the shaft seal is perfectly aligned on the thrust ring.

- Tighten hex nut (8) with 36 mm (1.42 in) socket wrench insert and reducing adapter, **BMW No. 33 1 720**.



Caution:

Nut must not damage shaft sealing ring.



Tightening torque:

Threaded ring
(thread cleaned + Hylomar SQ 32 M) 118 Nm
Nut for input bevel pinion
(thread cleaned + Loctite 270)..... 200 Nm

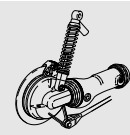

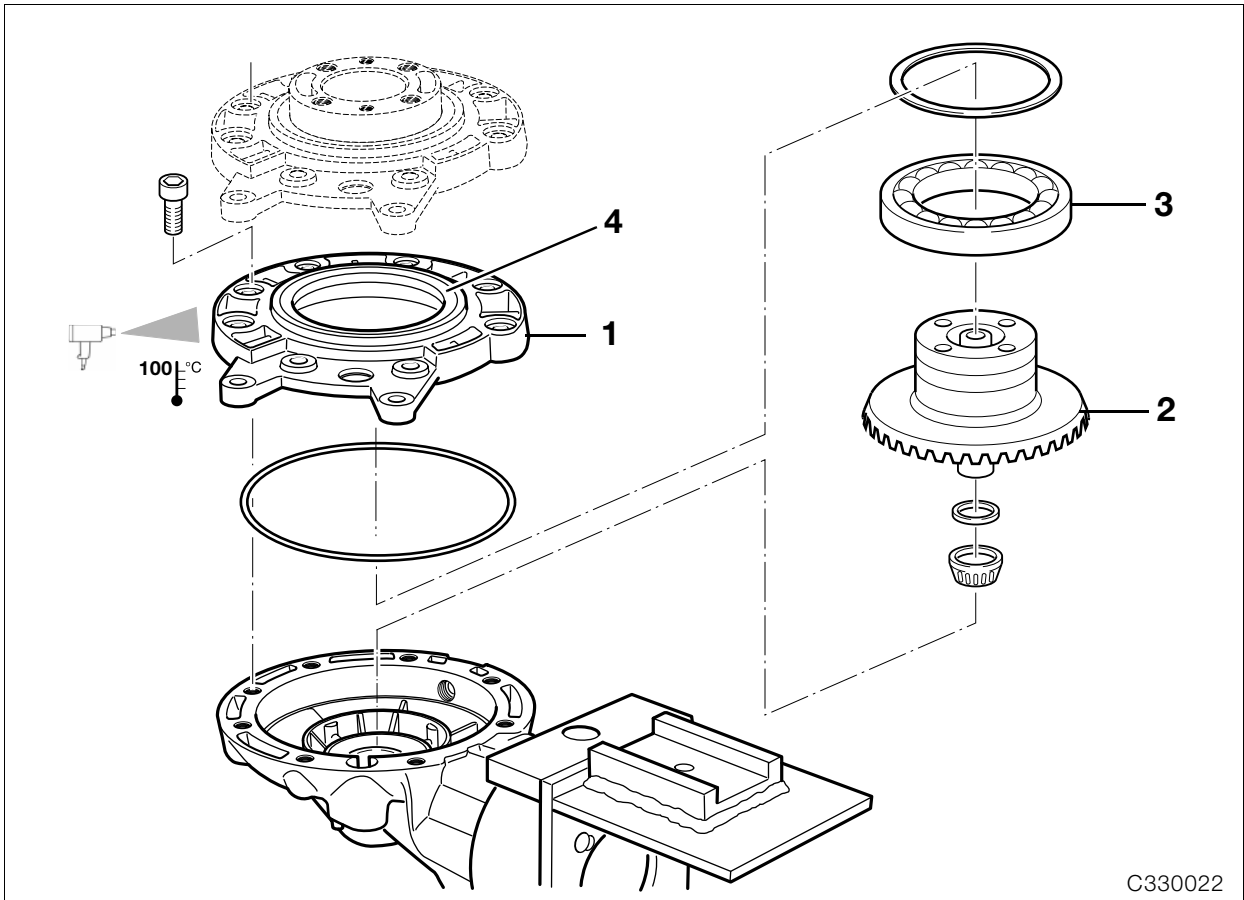

C330022

Removing and dismantling the crown wheel

- Remove housing cover (1) with crown wheel (2) and bearing (3).
- Heat housing cover to 100 °C (212 °F) and pull it off.
- Force shaft seal (4) out of housing cover with drift.

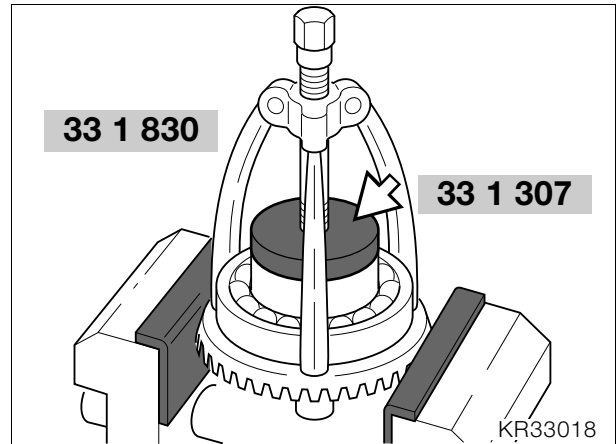

- Clamp crown wheel in vice with protective jaws.
- Insert thrust block (arrow), **BMW No. 33 1 307**.
- Use puller, **BMW No. 33 1 830**, to pull off the deep-groove ball bearing.

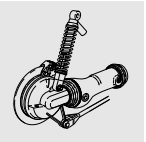

Assembling/installing crown wheel

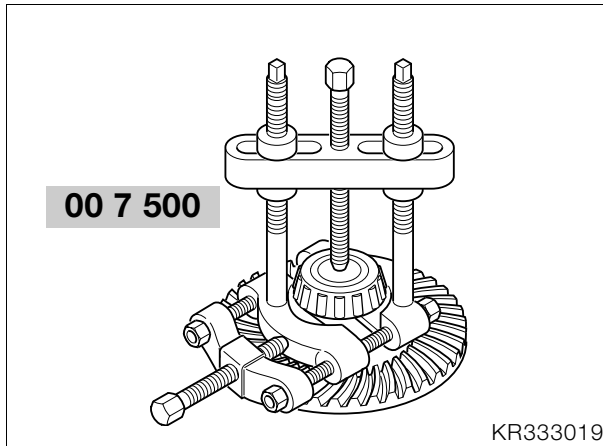

- Using puller, **BMW No. 00 7 500**, pull taper roller bearing off crown wheel.

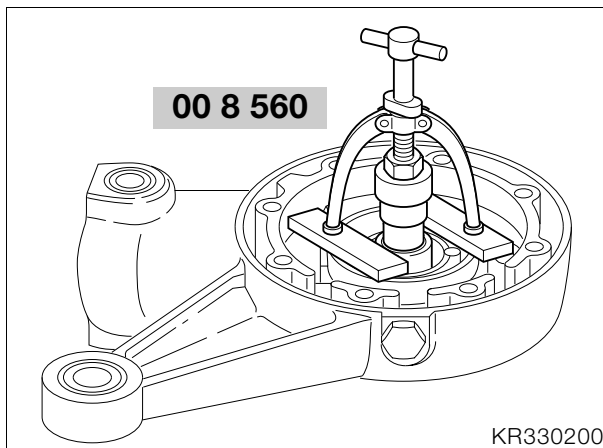

- Pull out the outer race using internal puller, **BMW No. 00 8 560**.

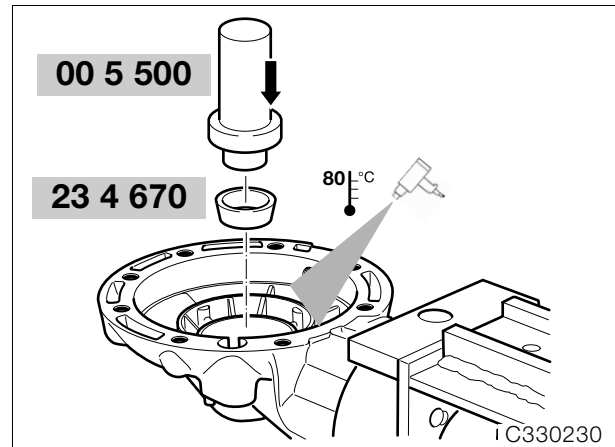

- Heat the housing to 80 °C (176 °F).
- Insert the outer race in the bearing seat with drift, **BMW No. 23 4 670**, and handle, **BMW No. 00 5 500**.
- Check that outer race is correctly seated by striking gently.



Note:

If new parts are installed (e.g. taper roller bearing), check tooth backlash and adjust if necessary.

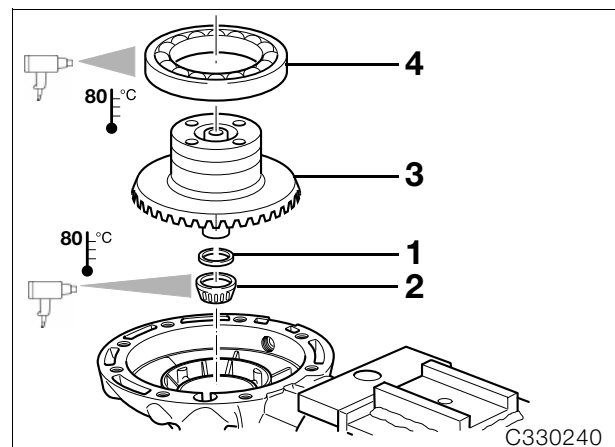

- Place the existing spacer ring (1) on the crown wheel.
- Heat taper roller bearing (2) to 80 °C (176 °F) and push it on.
- Install crown wheel (3).
- Heat deep-groove ball bearing (4) to 80 °C (176 °F) and place it in position.

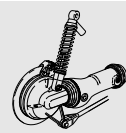

Checking/adjusting backlash

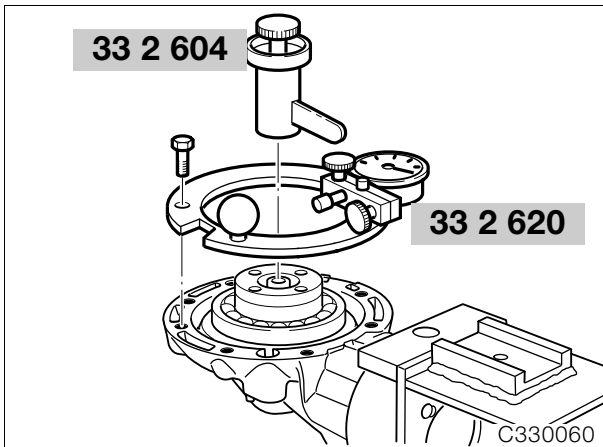

- Attach measuring device, **BMW No. 33 2 620**, with dial gauge to crown wheel and secure to housing with the knurled screw.
- Attach measuring arm, **BMW No. 33 2 604**, centrally to crown wheel.

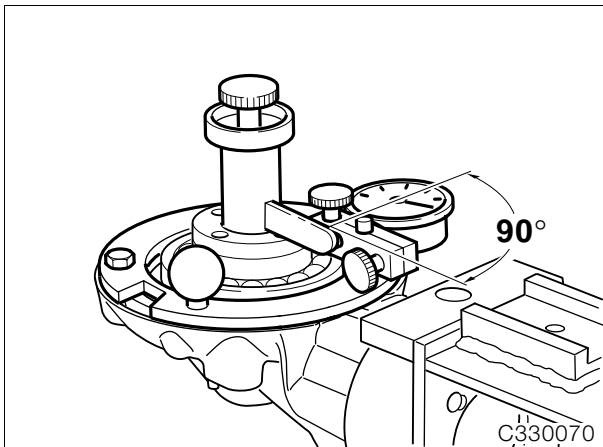

- With the palm of the hand, press the crown wheel into the housing and turn to and fro to check tooth backlash.



Note:

Check tooth backlash at three points 120 degrees apart; turn the bevel pinion with the crown wheel.

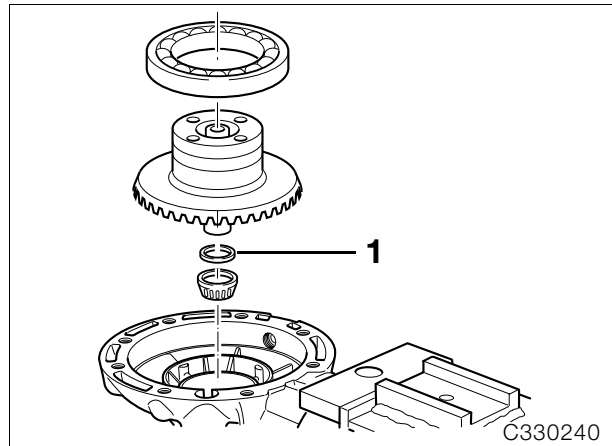

- Compensate for excessive backlash by inserting a thinner shim washer, and for insufficient backlash by inserting a thicker shim washer (1).

Backlash:

(adjust without oil)..... 0.07...0.16 mm (0.0027...0.0063 in)

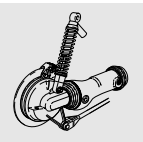

Checking tooth contact pattern

- The tooth contact pattern must be checked if the gear set, housing or input bevel pinion bearing have been renewed.

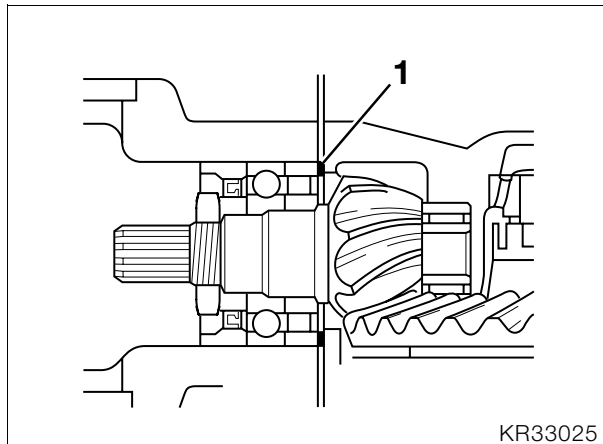

Note:

The contact pattern is adjusted at the shim washer (1) on the input bevel pinion.

- Degrease the tooth flanks on crown wheel and pinion, and coat with **engineer's blue**.
- Insert the crown wheel, press into housing with the palm of the hands and turn to and fro.

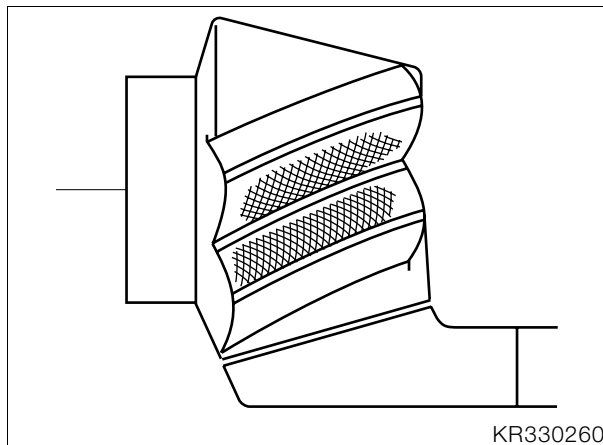

- If the correct spacer disc is installed, the following contact pattern appears with no load applied.



Note:

The contact point is central on front flank V.
The contact point is closer to the larger diameter on back flank R.



Caution:

Teeth should never make contact at the smaller diameter.

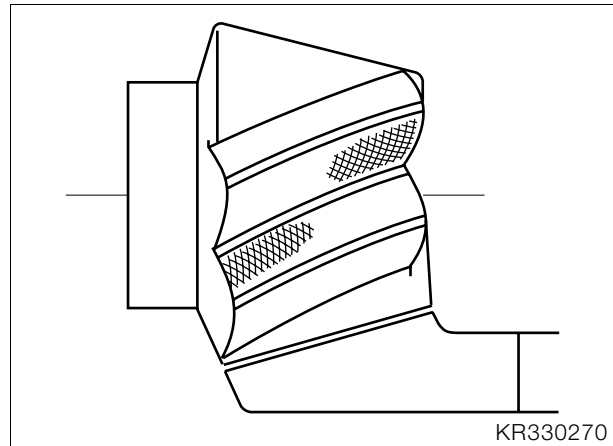

- If this contact pattern is obtained, a thinner shim washer must be installed.

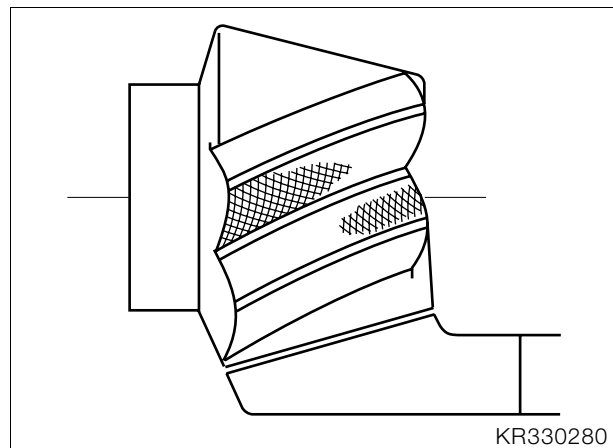

- If this contact pattern is obtained, a thicker shim washer must be installed.

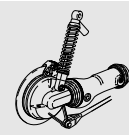

Shimming housing cover

- To obtain the correct roller bearing preload, the housing cover must be shimmed.

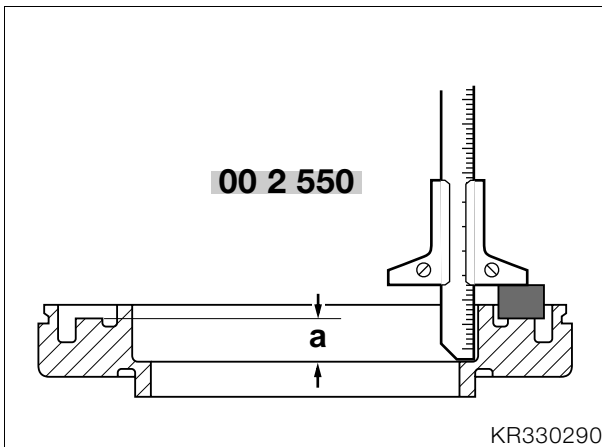

- Using depth gauge, **BMW No. 00 2 550**, measure distance a.

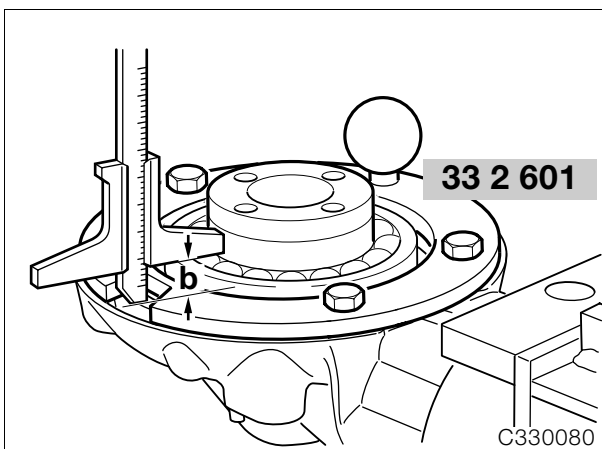

- Place measuring ring, **BMW No. 33 2 601**, in position and secure it.
- Measure from the outer ball bearing race through the cutout in the measuring ring to the housing joint face and determine distance b.
- Distance a – distance b = shim thickness (without preload).
- Apply a light coat of grease to the selected shim washer, and install it.

Preload:..... 0.05...0.1 mm (0.0020...0.0039 in)

Installing housing cover

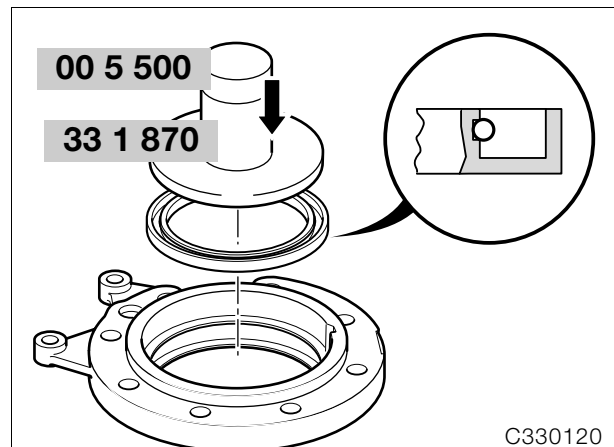

- Lightly oil the lip and outer edge of the sealing ring.
- Using drift, **BMW No. 33 1 870**, and handle, **BMW No. 00 5 500**, drive in the sealing ring.
- Install O-ring and apply a light coat of oil/grease.
- Heat housing cover to 80 °C (176 °F)/install.
- Tighten retaining bolts in a crosswise pattern.

! Tightening torque:

Housing cover..... 35 Nm

Installing splined element

- Coat splines on input pinion with **Staburags NBU 30 PTM**.
- Fit sliding element to drive pinion.
- Locate retaining ring with gentle blows (plastic hammer).

Removing and installing taper roller bearing

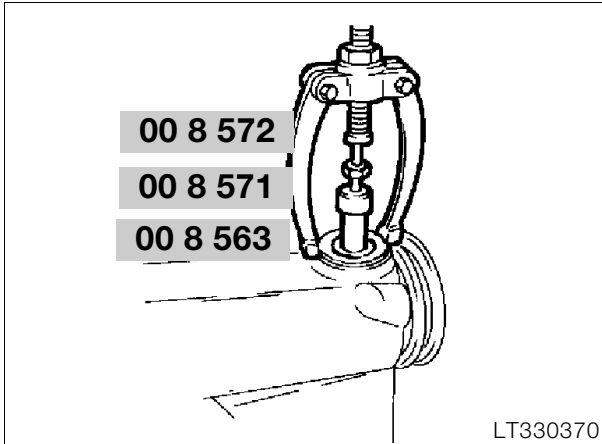

- Pull the taper roller bearing out with counter-support, **BMW No. 00 8 572**, and internal puller 21/2, **BMW No. 00 8 571**.
- Pull out outer race with internal puller 21/5, **BMW No. 00 8 563**.
- To install the bearing, heat the swinging arm to 80 °C (176 °F).
- Bearing with drift, **BMW No. 33 5 700**

Removing and installing flexible gaiter

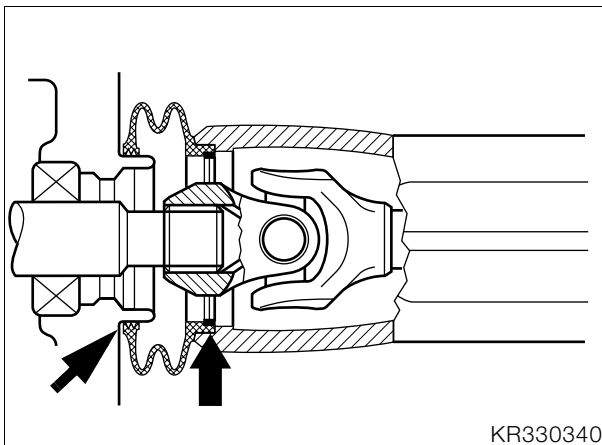

- Pull flexible gaiter with circlip out of swinging arm.
- When installing, coat inner and outer sealing lips (arrows) with **Staburags NBU 30 PTM**.

⚠ Caution:

Drive shaft clearance when suspension is compressed:
aperture in retaining ring must be horizontal.

Removing drive shaft

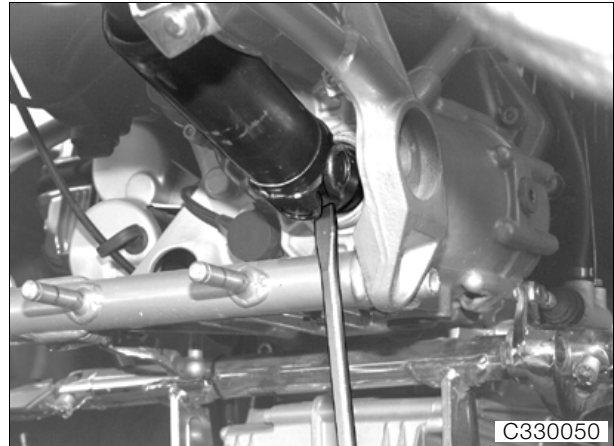

- Press off drive shaft.

⚠ Caution:

Avoid scratching painted parts; use an underlay if necessary.

Checking universal joint for wear

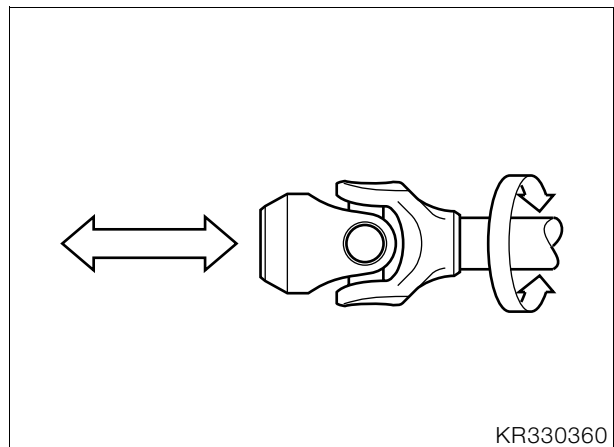

- Determine end float and face runout.

Installing drive shaft

- Coat the splines on the output shaft with **Staburags NBU 30 PTM**.
- Fit drive shaft to output shaft.
- Engage the snap ring with gentle blows (plastic hammer).

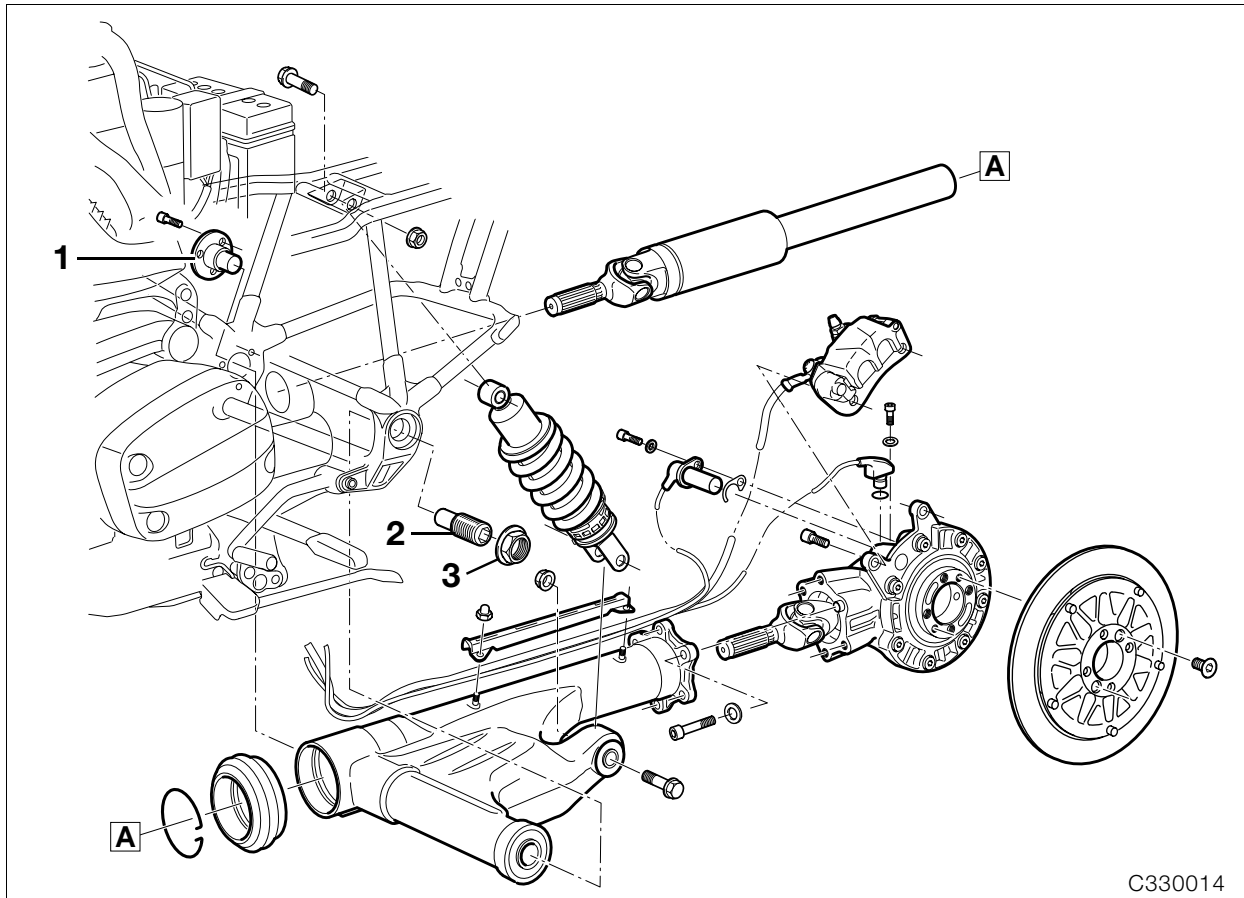

C330014

Installing rear swinging arm

- Slide swinging arm over drive shaft as far as possible until rubber gaiter connects on housing neck.
- Install fixed bearing journal (1).
- Screw in free bearing journal (2).
- Tighten fixed bearing journal.
- Tighten free bearing journal.
- Tighten locknut (3).
- Install the left swinging arm bearing cap.

Caution:

Make sure that the O-ring is in good condition.
The drain hole must point down.

- Secure suspension strut (1).

Tightening torque:

Fixed bearing journal	10 Nm
Free bearing journal	7 Nm
Locknut.....	160 Nm
Suspension strut to swinging arm	50 Nm

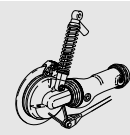

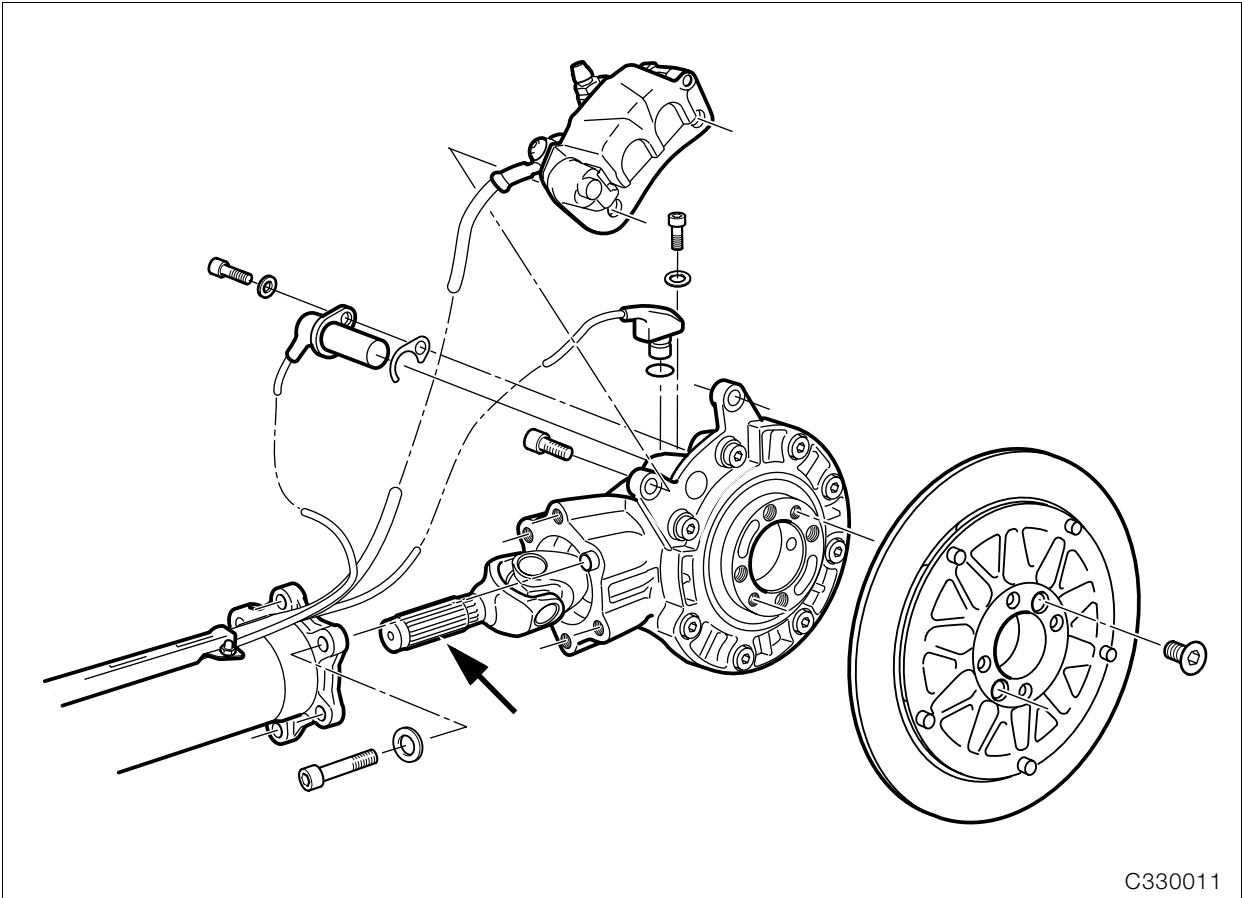

Installing rear wheel drive

- Coat splines at sliding element (arrow) with **Staburags NBU 30 PTM**.
- Offer up the rear wheel drive assembly and guide the sliding element into the drive shaft.

Tightening torque:

Rear wheel drive to swinging arm..... 21 Nm

- If necessary, fill with oil.

Fill quantity:

(up to lower edge of thread on oil filler plug)

Initial

fillingapp. 0.20 l (0.35 Imp. pint/0.21 US quart)

During oil

changesapp. 0.18 l (0.32 Imp. pint/0.19 US quart)

Oil grade:

Brand-name hypoid gear oil, SAE 90, API class GL 5

- **[ABS]** Install the brake disc in the previously marked position.
- Install the rear wheel.
- Install brake caliper

Caution:

Do not damage brake pads; do not tilt when installing.

- Install speedometer signal transmitter.
- **[ABS]** Install sensor.

- **[ABS]** Check that sensor gap is correct.

ABS rear

sensor gap: 0.50...0.55 mm (0.019...0.021 in)

Removing and installing suspension strut



Note:

To remove the suspension strut, support the rear axle.



Tightening torque:

Suspension strut to swinging arm/rear frame..... 50 Nm

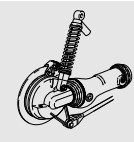

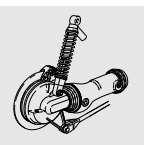

34 Brakes



Contents

Page

Technical data	3
Removing and installing front brake caliper	5
Dismantling and assembling front brake caliper	6
Dismantling front brake caliper	6
Assembling front brake caliper	6
Removing and installing rear brake caliper	7
Dismantling and assembling rear brake caliper	8
Dismantling rear brake caliper	8
Assembling rear brake caliper	8
Removing and installing front brake disc	9
Removing/installing rear brake disc	10
Removing and installing front ABS sensor	11
Adjusting front ABS sensor gap	12
Marking sensor wheel	12
Checking and adjusting sensor gap	12
Removing and installing rear ABS sensor	13
Adjusting rear ABS sensor gap	14
Marking sensor wheel	14
Checking and adjusting sensor gap	14
Removing and installing rear brake master cylinder	15
Checking and adjusting reliefclearance of piston rod	15
Removing and installing brake pedal	15
Removing and installing ABS unit	16

Contents

Page

Removing the ABS unit	16
Installing the ABS unit	17
Removing and installing ABS relay and relay base	18
Removing ABS relay	18
Installing the ABS relay	18
Removing ABS relay base	18
Installing the ABS relay base	19
Removing and installing brake lines	20
Removing and installing front brake line	20
Removing and installing rear brake line	21

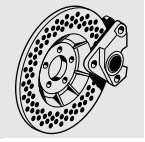

Technical data		R 850 C	R 1200 C
Brake fluid		DOT 4	
Minimum lining thickness	mm (in)	1.5 (0.06) Wear indicator: Front brake pads/cutouts in pad material Rear brake pads/hole in wheel-side brake pad backplate enables brake disc to be seen when minimum pad thickness is reached.	
Front wheel			
Brake disc dia.	mm (in)	305 (12.00)	
Brake disc thickness	mm (in)	5 ^{± 0.1} (0.20 ^{± 0.004})	
Minimum thickness	mm (in)	4.5 (0.18)	
Brake pad surface area	cm ² (sq in)	100 (15.5)	
Piston dia. in brake caliper	mm (in)	32/34 (1.26/1.34)	
Piston diameter in handlebar lever cylinder	mm (in)	20 (0.79)	
Sensor gap, front	mm (in)	0.45 ... 0.55 (0.020 ... 0.022)	
Brake pad		Semi-metallic	
Rear wheel			
Brake disc dia.	mm (in)	285 (11.22)	
Brake disc thickness	mm (in)	5.0 (0.20)	
Minimum thickness	mm (in)	4.5 (0.18)	
Permissible lateral runout	mm (in)	0.20 (0.008)	
Brake pad surface area	cm ² (sq in)	34 (5.27)	
Piston dia. in brake caliper	mm (in)	26/28 (1.02/1.10) with insulating piston	
Piston dia. in foot brake cylinder	mm (in)	12 (0.47)	
Sensor gap, rear	mm (in)	0.45 ... 0.55 (0.020...0.022)	
Brake pad		Semi-metallic	

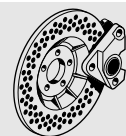

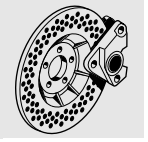

Removing and installing front brake caliper

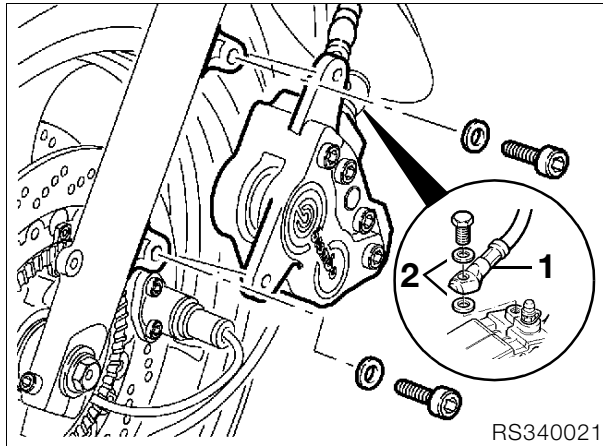

- Drain fluid from brake system.
- Detach brake line (1).



Caution:

Do not allow brake fluid to come into contact with painted parts of the motorcycle, because brake fluid destroys paint.

- Unscrew the brake caliper.

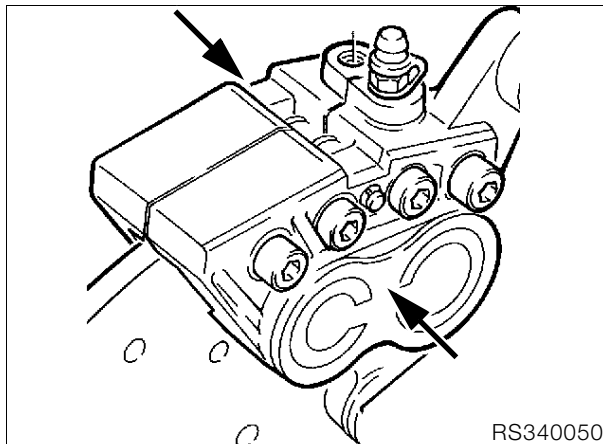

- Force back the brake pads/pistons (arrows).
- Carefully remove the brake caliper.



Caution:

Do not damage brake pads.

- Install by following the above work instructions in the reverse order.
- Force back the brake pads/pistons.
- Fill/bleed the brake system.



Caution:

Use new sealing rings (2).
Do not damage brake pads.



Tightening torque:

Brake caliper at fork slider tube 40 Nm
 Brake hose to brake caliper 15 Nm
 Bleed screw at brake caliper 7 Nm

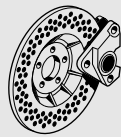

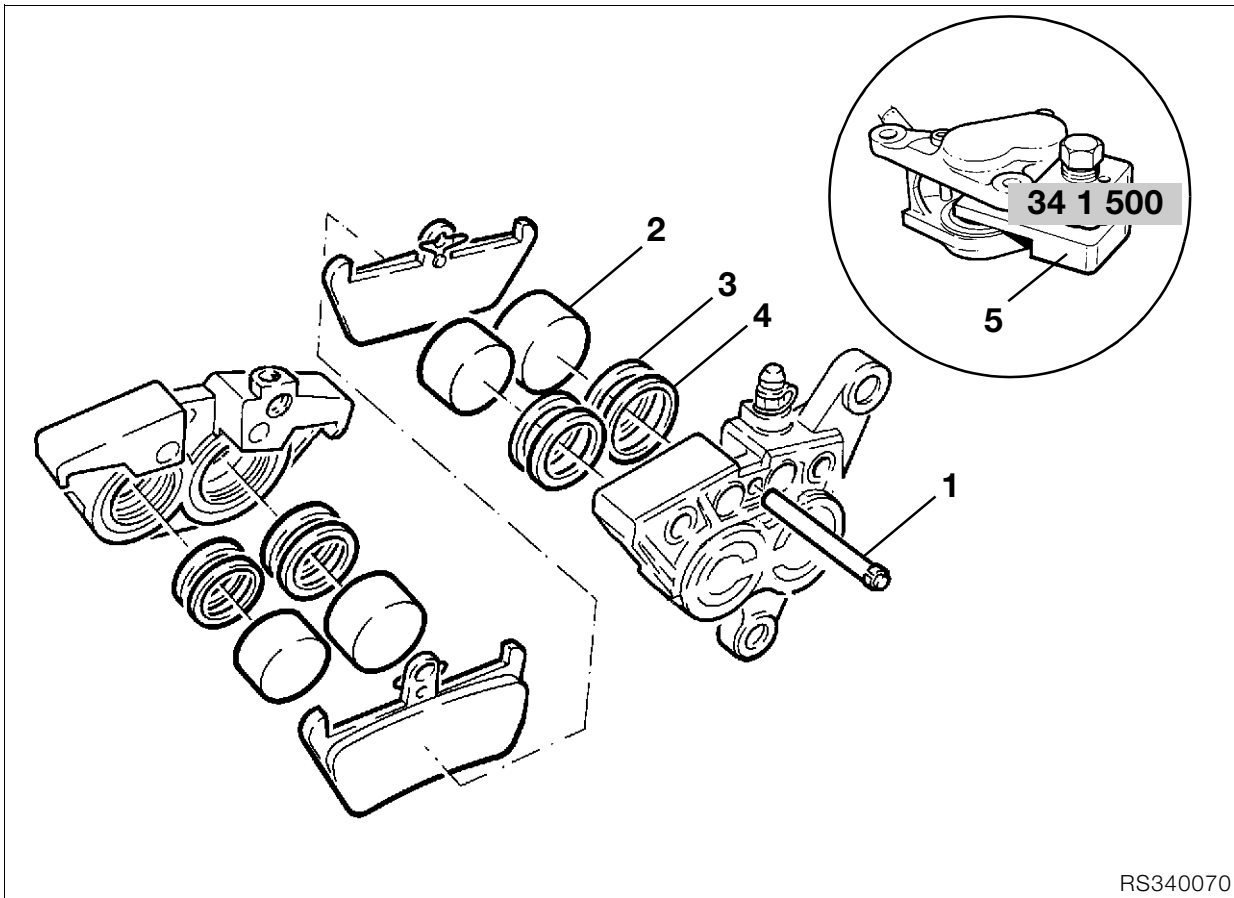
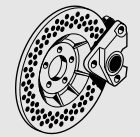

RS340070

Dismantling and assembling front brake caliper



Caution:

The brake caliper halves must **not be unscrewed!**

Dismantling front brake caliper

- Remove the brake caliper.
- Remove keeper from retaining pin (1).
- Drive out the retaining pin (1) from the wheel side.
- Pull the brake pads out downwards.
- Seal the bleed screw.



Tightening torque:

Bleed screw at brake caliper 7 Nm

- Hold a cloth over the brake caliper.
- **Carefully** press out brake pistons (2), using a compressed air gun at the brake line connection.



Caution:

Do not allow your fingers to become trapped between the pistons; risk of injury.

- Remove the two sealing rings (3,4) from the left/right brake cylinder bores.
- Examine the brake caliper pistons for damage.

Assembling front brake caliper

- Coat new sealing rings (3,4) with brake fluid and install.
- Coat brake caliper pistons (2) with brake fluid and insert.



Caution:

Do not tilt the brake pistons when installing.

- Using piston resetting tool (5), **BMW No. 34 1 500**, press the pistons fully back.
- Install the brake pads.

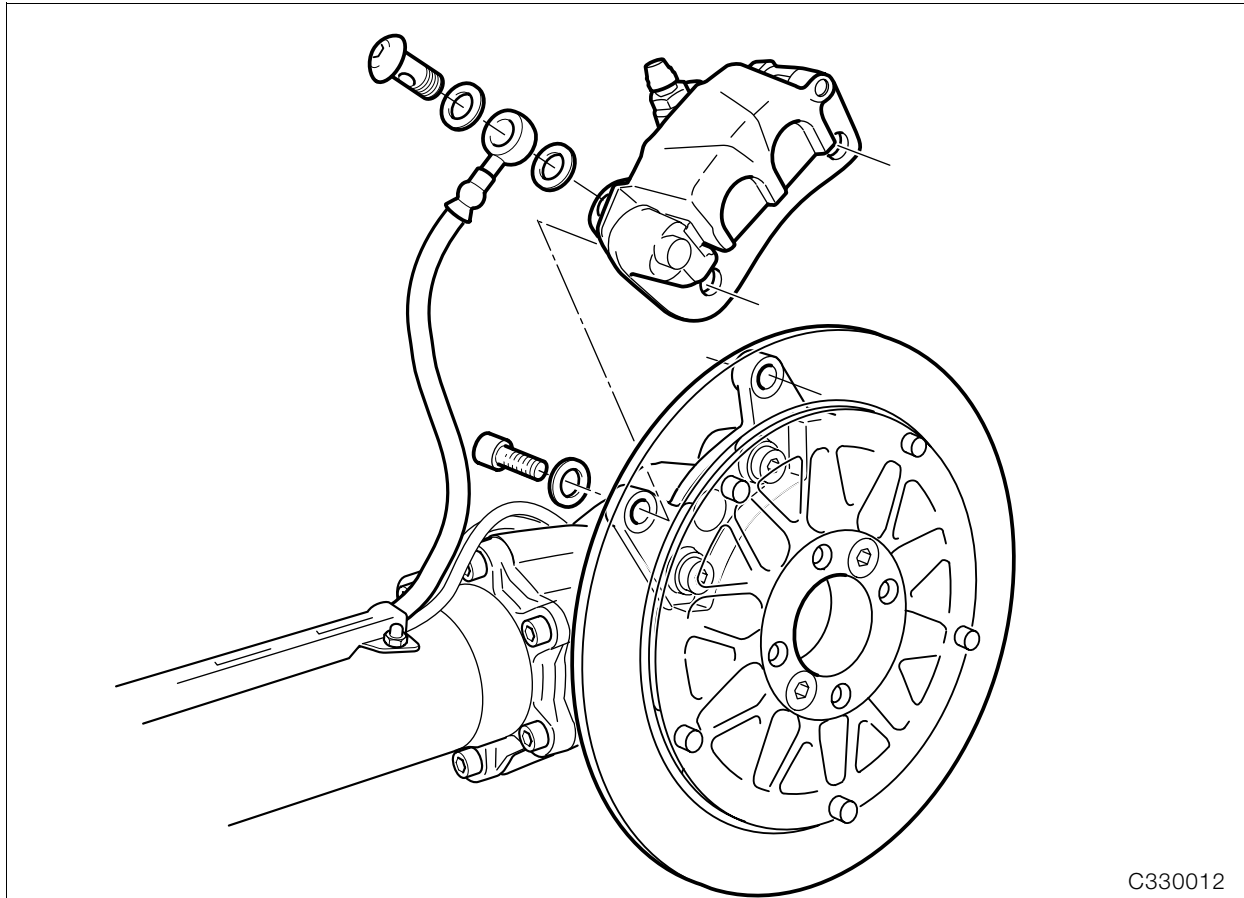

C330012

Removing and installing rear brake caliper

- Drain fluid from brake system.



Caution:

Do not allow brake fluid to come into contact with painted parts of the motorcycle, because brake fluid destroys paint.

- Detach the brake line from the brake caliper.
- Unscrew the brake caliper.
- Install by following the above work instructions in the reverse order.
- Force back the brake pads/pistons.
- Fill/bleed the brake system.
- To bleed, release the brake caliper and position it with the bleed nipple at the highest point.



Caution:

Renew sealing rings for brake line.
Do not damage brake pads.



Tightening torque:

Brake caliper to rear wheel drive 40 Nm
 Brake hose to brake caliper 15 Nm
 Bleed screw at brake caliper 4 Nm

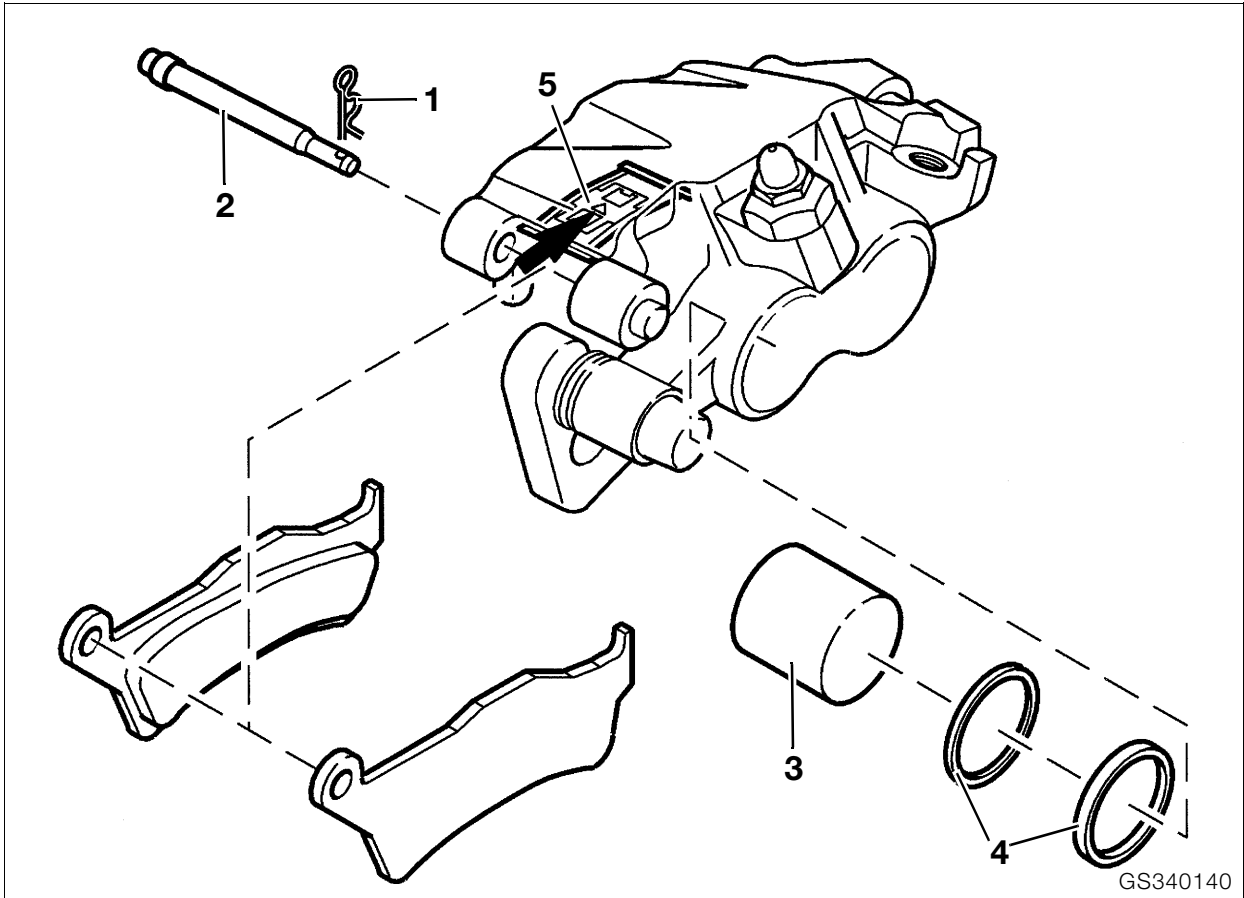

Dismantling and assembling rear brake caliper

Dismantling rear brake caliper

- Remove keeper (1).
- Drive out retaining pin (2).
- Take out brake pads.
- Seal the bleed screw.



Tightening torque:

Bleed screw at brake caliper 4 Nm

- Hold a cloth over the brake caliper piston.
- **Carefully** press out brake piston (3) with a compressed air gun applied to the connecting bore; work at low air pressure.



Caution:

Keep fingers away from gap between pistons and side contact face of brake pads; risk of injury.

- Remove sealing rings (4) from left/right cylinder.
- Inspect the brake caliper piston for hairline cracks/score-marks/other damage.

Assembling rear brake caliper

- Coat the new sealing rings with brake fluid and insert them into the left/right brake caliper cylinders.
- Coat both brake caliper pistons with brake fluid and install them.



Caution:

Do not tilt the brake pistons when installing.

- Coat the adapter plate locating pins with **Shell Retinax A** and install the adapter plate.
- Insert locating plate (5) into brake caliper.



Note:

The installed position must be correct (arrow pointing in forward-travel direction).

- Insert brake pads and secure with retainers.

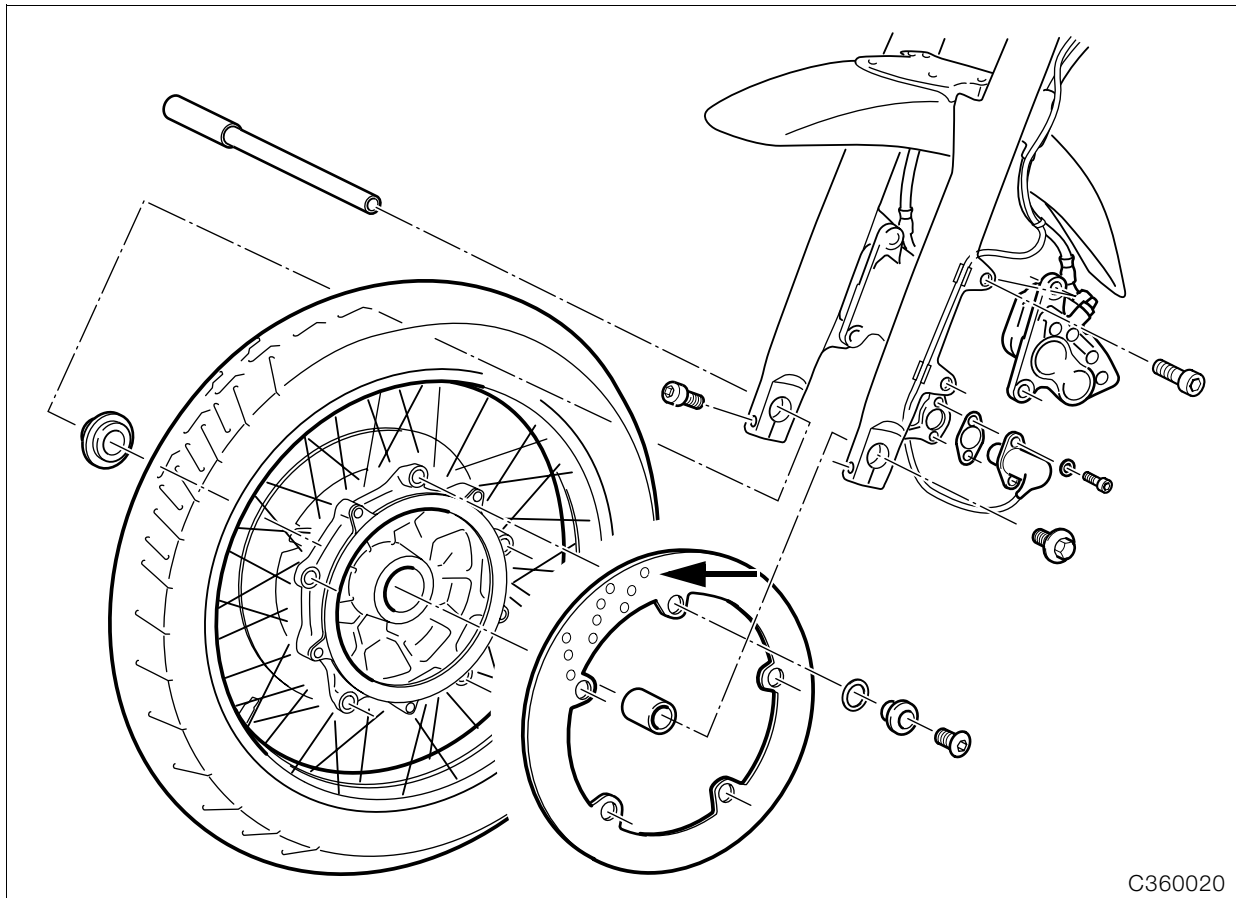

Removing and installing front brake disc

- Degrease brake discs before installing.



Note:

Installed direction (arrow) of brake discs must be correct.



Tightening torque:

(clean thread + Loctite 243)..... 24 Nm



Caution:

Check/adjust the sensor gap.

Sensor gap:..... 0.45...0.55 mm (1.77...2.22 in)

Removing/installing rear brake disc

- Remove rear wheel.
- Remove the brake caliper.

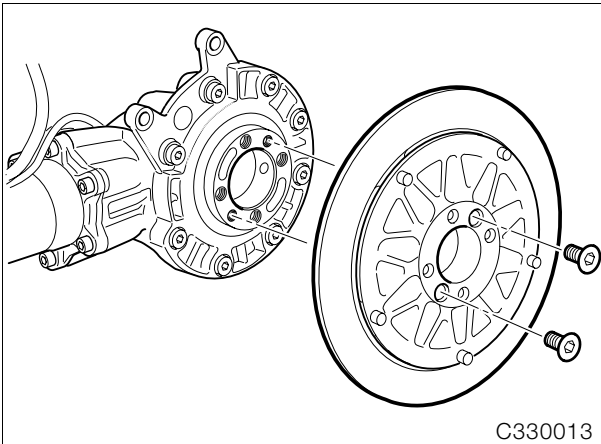

- Heat the brake disc retaining screws to 120 °C (248 °F) and remove them.



Note:

Mark the position of the brake disc.
The sensor gap setting remains unchanged.

- Install by following the above work instructions in the reverse order.
- Degrease the brake disc before installing.



Caution:

[ABS] Check sensor gap and adjust with spacing plates if necessary.

[ABS] If the brake disc and therefore the sensor wheel are renewed, the disc's lateral runout must be determined/marked.

Sensor gap:..... 0.45...0.55 mm (1.77...2.22 in)



Tightening torque:

Brake disc to rear wheel drive
(clean thread + Loctite 273)..... 21 Nm

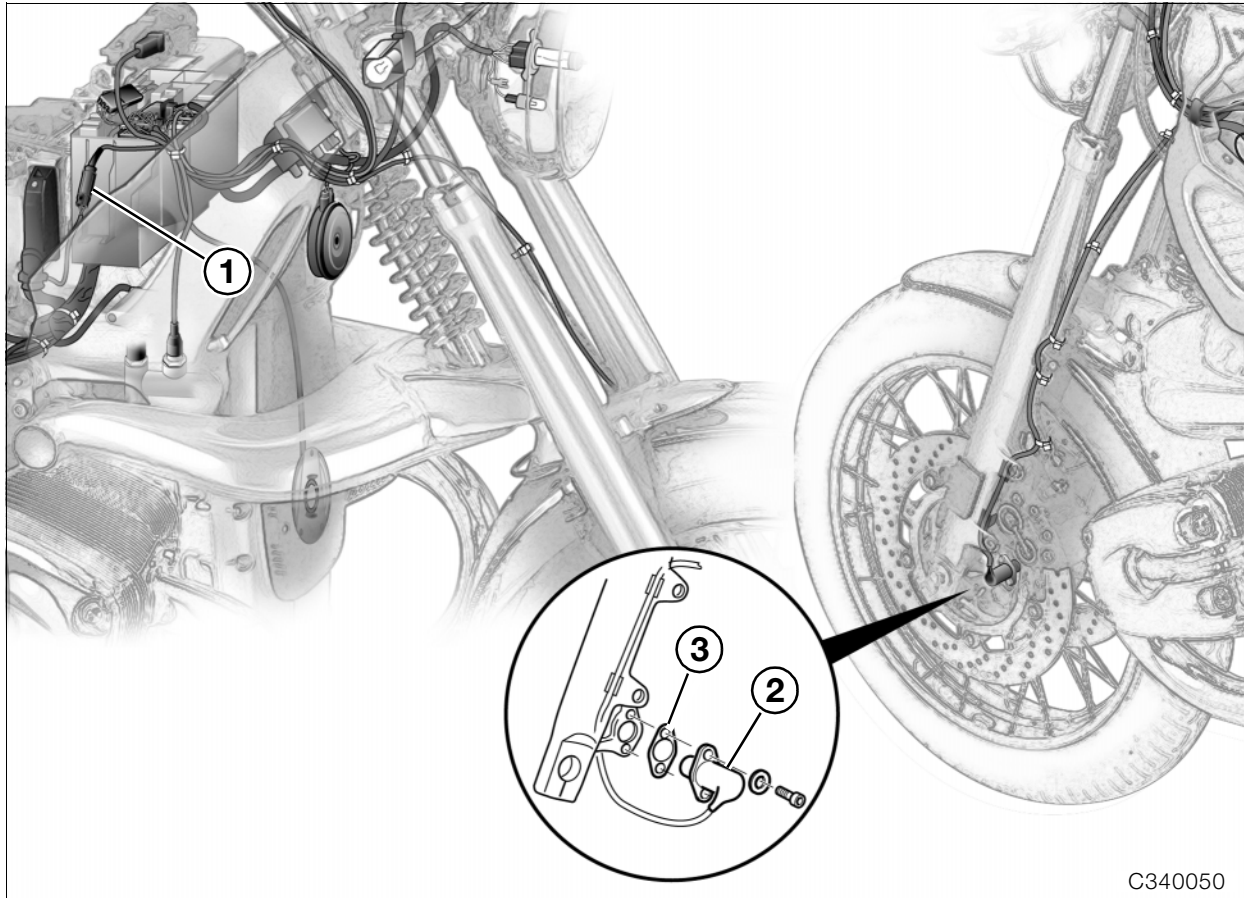

C340050

Removing and installing front ABS sensor

- Remove fuel tank.
- Separate plug connector (1) in sensor line.
- Remove sensor (2) with **Torx T 25**.
- Install by following the above work instructions in the reverse order.



Caution:

Run the sensor line correctly.
Check sensor gap and adjust if necessary with spacer plate (3).

Sensor gap:..... 0.45...0.55 mm (1.77...2.22 in)



Tightening torque:

Sensorhandtight, 4 Nm

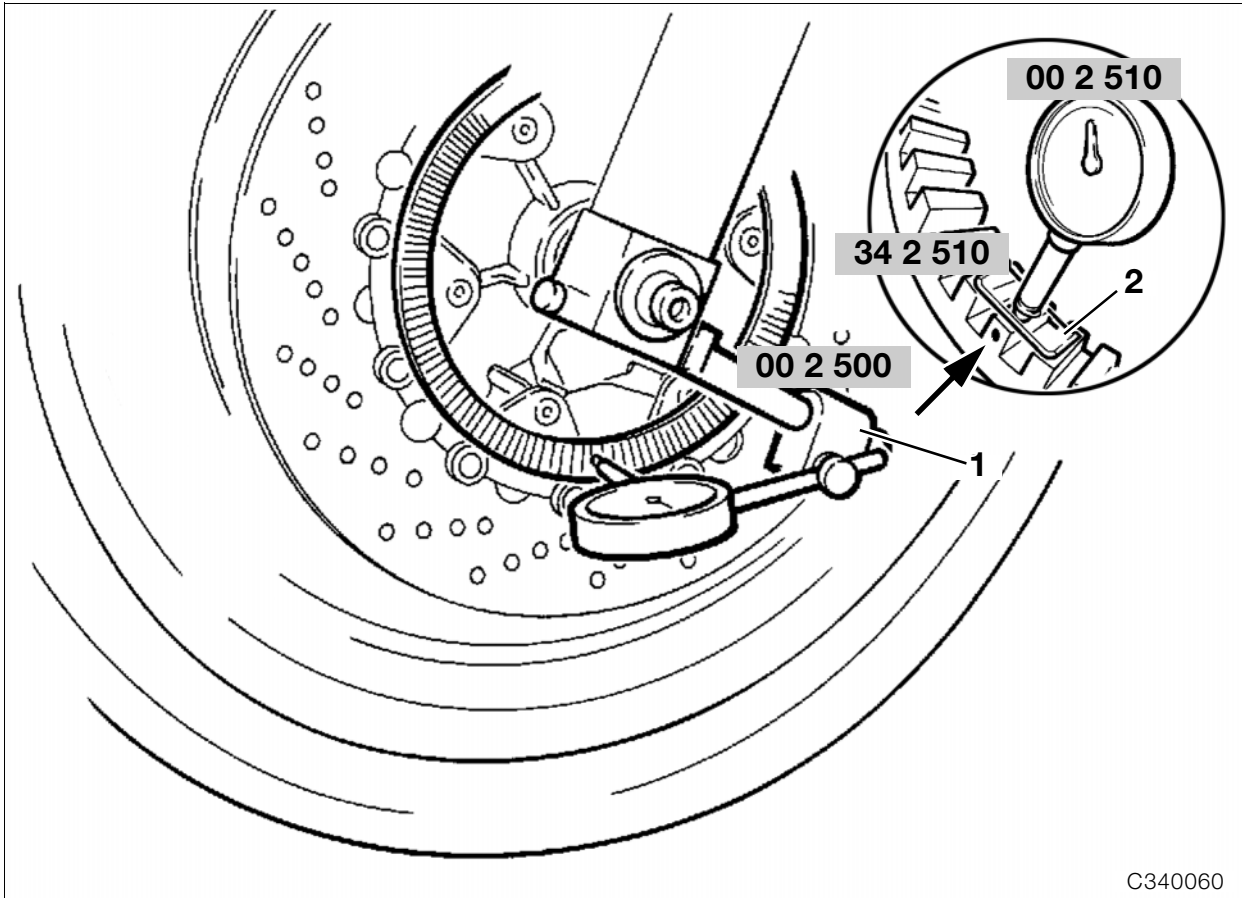
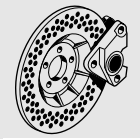

C340060

Adjusting front ABS sensor gap

Marking sensor wheel

- Take load off front wheel/lift clear of ground.
- Attach dial gauge holder (1), **BMW No. 00 2 500**, with dial gauge, **BMW No. 00 2 510**, and measuring shoe (2), **BMW No. 34 2 510**, to the fork slider tube.
- Zero the dial gauge.
- Measure axial runout over the entire circumference.
- Using a paint pencil, make a permanent mark at the point where the sensor is farthest away from the sensor wheel (arrow).

Checking and adjusting sensor gap

- Check/adjust at the marked point.
- If necessary, remove/install sensor with **Torx T 25** and adjust sensor gap with spacing plates.

Sensor gap:..... 0.45...0.55 mm (1.77...2.22 in)



Caution:

After adjusting, check that the sensor can move freely for a complete turn of the wheel.

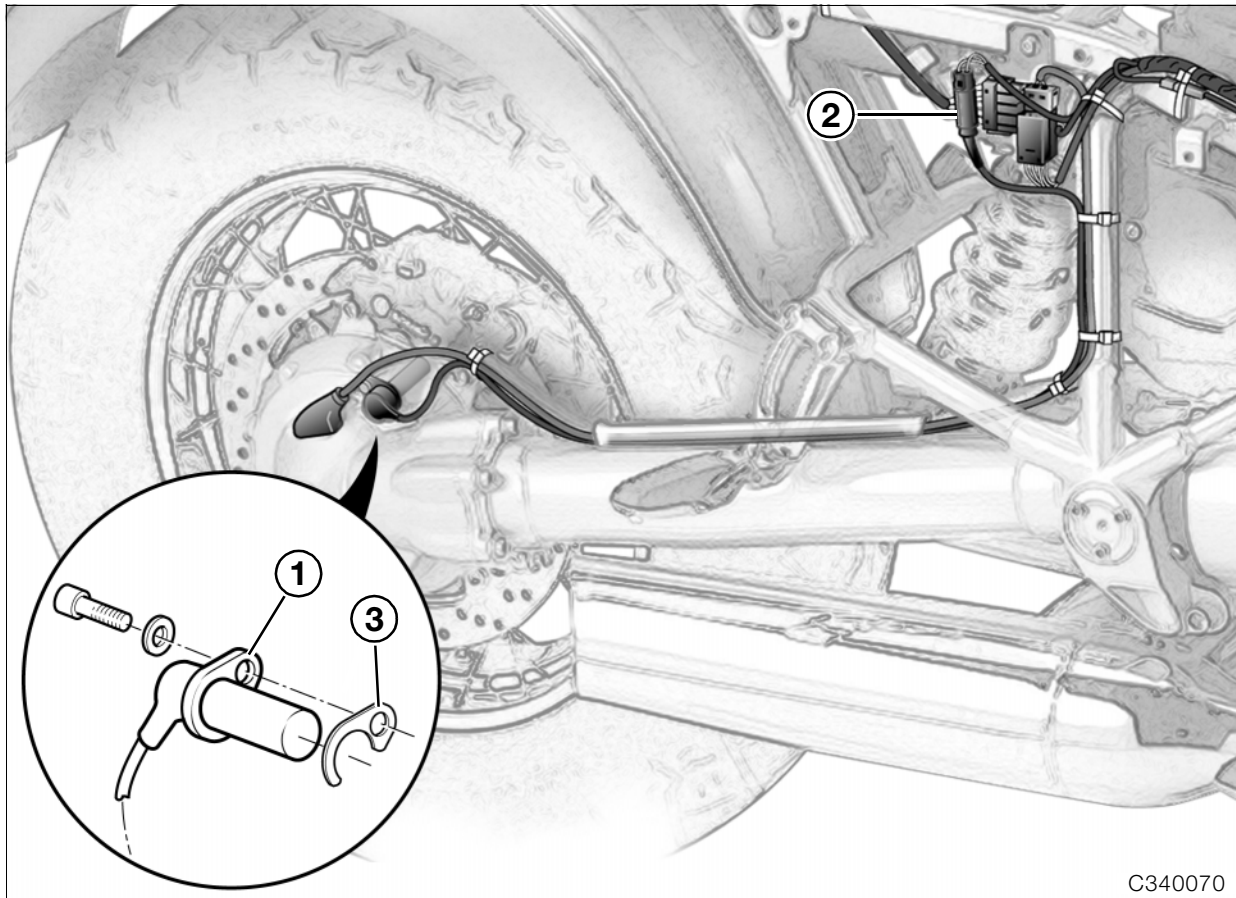

C340070

Removing and installing rear ABS sensor



Note:

To install spacing shims, pull the sensor out by a small amount only and pull the spacing shims out upwards.

- Before removing/installing, clean the sensor bore.
- Using **Torx T 25**, detach sensor (1).
- Separate plug connector (2) in the sensor line.
- Install by following the above work instructions in the reverse order.
- Coat O-rings with oil before installing.



Caution:

Run the sensor line correctly.
Check sensor gap and adjust if necessary with spacer plates (3).

Sensor gap:..... 0.45...0.55 mm (1.77...2.22 in)



Tightening torque:

Sensorhandtight, 4 Nm

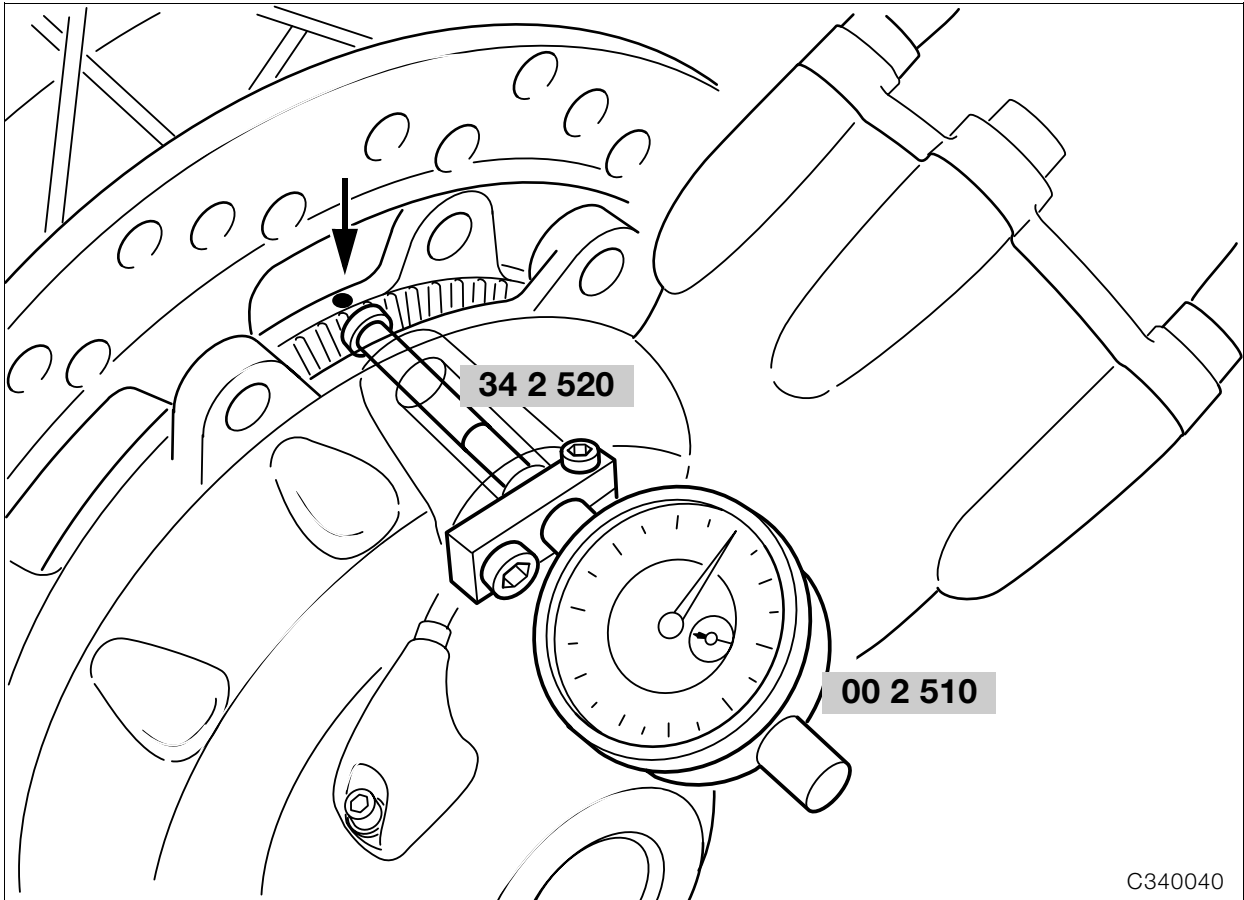

C340040

Adjusting rear ABS sensor gap

Marking sensor wheel

- Before removing/installing, clean the sensor bore.
- Using **Torx T 25**, detach the sensor.
- Screw dial gauge holder with measuring shoe and extension, **BMW No. 34 2 520**, with dial gauge, **BMW No. 00 2 510**, firmly to the sensor mount.
- Zero the dial gauge.
- Measure axial runout over the entire circumference.
- Make a permanent paint pencil mark at the point where the sensor wheel is farthest away from the sensor (arrow).



Caution:

If parts are replaced (brake disc etc.) and a used or previously marked sensor wheel is installed, the sensor ring must be measured and marked again. Remove the old marking.

Checking and adjusting sensor gap

- Check/adjust at the marked point.
- If necessary, remove/install sensor with **Torx T 25** and adjust sensor gap with spacing plates.



Caution:

After adjusting, check that the sensor wheel is free to turn at all points on its circumference.

Sensor gap:..... 0.45...0.55 mm (1.77...2.22 in)



Tightening torque:

Sensorhandtight, 4 Nm

Removing and installing rear brake master cylinder

- Drain fluid from brake system.



Caution:

Do not allow brake fluid to come into contact with painted parts of the motorcycle, because brake fluid destroys paint.

- Detach the brake line and hose.
- Slacken off the pin at the linkage.
- Detach brake master cylinder.
- Install by following the above work instructions in the reverse order.
- Attach non-reusable hose clip with pliers, **BMW No. 13 1 500**.



Caution:

Bleed the brake system carefully.
Check/adjust piston rod sniffling-action play.



Tightening torque:

Master cylinder to footrest plate 9 Nm

Checking and adjusting relief clearance of piston rod

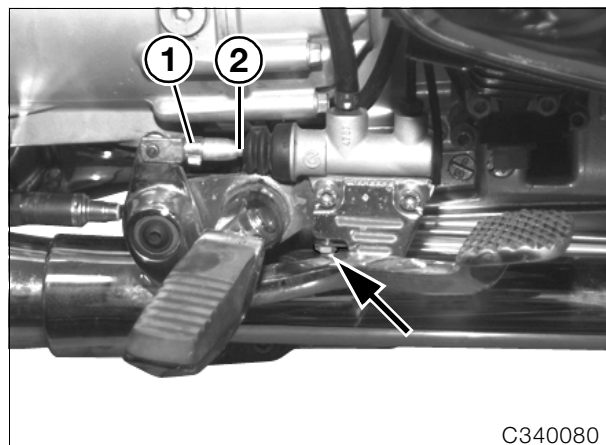

C340080

- Insert a feeler gauge of the correct thickness between the adjusting screw/brake lever and the stop (arrow).

Feeler gauge thickness: 0.2 mm (0.008 in)

- Release locknut (1).
- Insert piston rod (2), turning to right until clearance is present.
- Turn the piston rod carefully to the left to withdraw it again until no clearance is present; lock it in this position.
- Tighten locknut/check clearance again.

Removing and installing brake pedal

- Lubricate pivot bushing with **Shell Retinax A**.



Caution:

Check/adjust piston rod relief clearance.
See removal and installation of brake master cylinder.

The brake light must come on as soon as the rear brake begins to take effect.



Tightening torque:

Brake pedal to footrest plate
(thread free from grease) 37 Nm

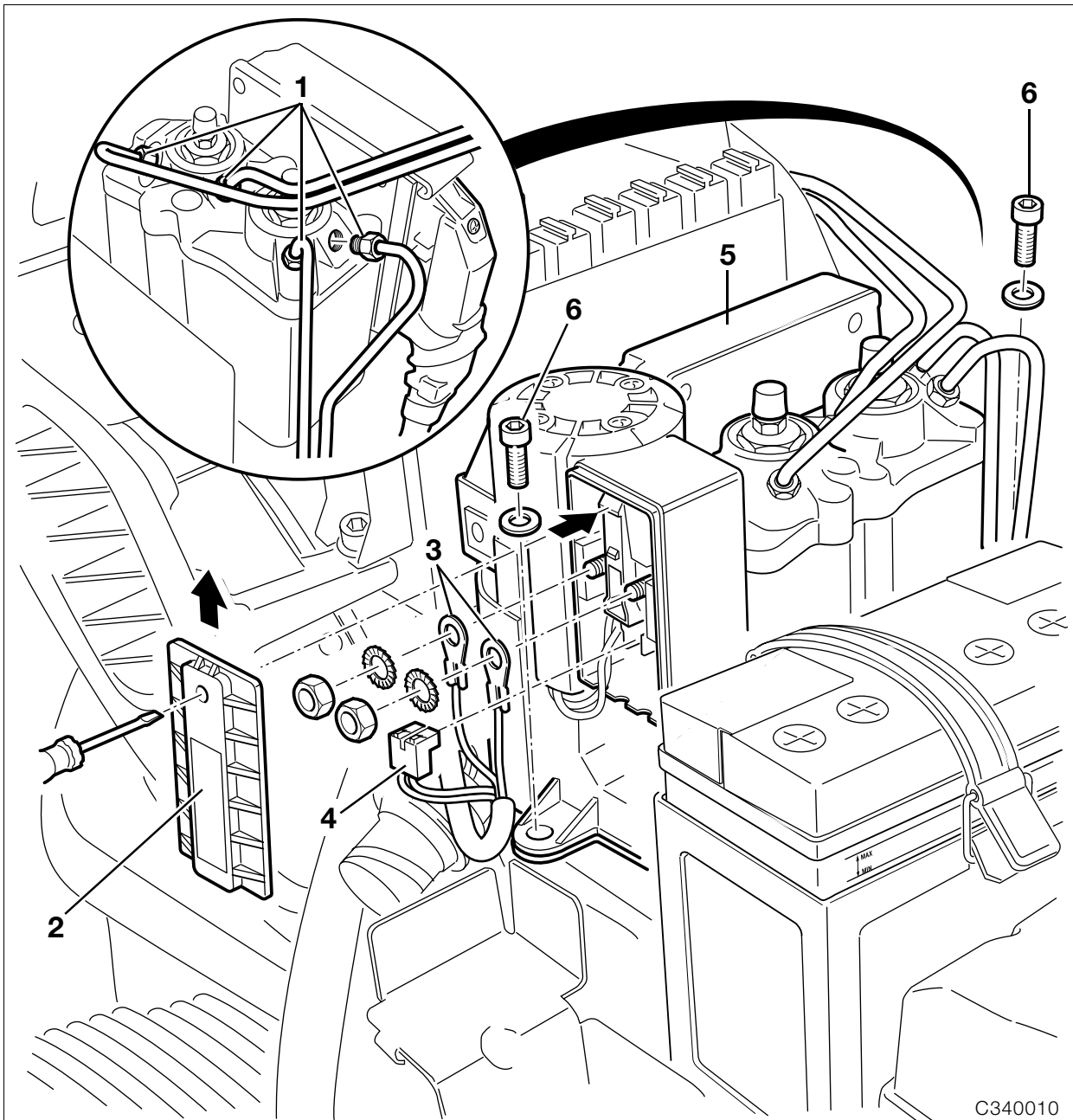

C340010

Removing and installing ABS unit



Caution:

Work on the ABS unit is only to be performed by an authorized BMW workshop.

Removing the ABS unit

- Remove fuel tank.
- Disconnect ABS brake lines (1) at ABS unit.



Caution:

If brake fluid escapes, it may damage paint. Line connections **must** be protected against dirt penetration; if necessary seal/cover over.

- Hold the front brake lever against the handlebar grip with a rubber band (to close the brake fluid feed bore).



Caution:

Switch off ignition, disconnect and insulate the ground (earth) strap.

- Remove cover (2) from ABS control unit, press the lock in with a screwdriver and pull the cover up.
- Detach wires (3).
- Pull off 2-pin plug (4).
- Pull off the central plug (5).
- Remove the ABS unit (6).

Installing the ABS unit

- Install the ABS unit (6).
- Connect the central plug (5).



Caution:

Make sure the cable is not at an angle, or its insulation may be damaged.

- Reconnect the 2-pin plug in the correct position, pushing the two halves fully together, and press the two wires into the center (smaller) cable entries.
- Push the two plugs for the connecting cable/wiring harness onto the threaded pins with the crimp at the front.
- Press the two cables into the remaining free cable entries.
- Tighten the nuts.



Caution:

Always use new self-locking nuts.



Tightening torque:

Battery -/M5 3.5 Nm
Battery +/M4 3 Nm

- Install a new cover.



Caution:

When sliding the cover on, make sure that all cables are correctly located in their cable entries. **Scrap** the old cover.

- Screw ABS brake lines (1) to ABS unit.
- Fill/bleed the brake system.
- Install the fuel tank.



Tightening torque:

ABS unit to holder
M6 screw 9 Nm
M6 screw (Torx)..... 5 Nm
Brake line to ABS unit 14 Nm
Bleed screw at ABS unit..... 9 Nm

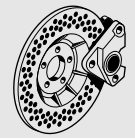

Removing and installing ABS relay and relay base

Removing ABS relay

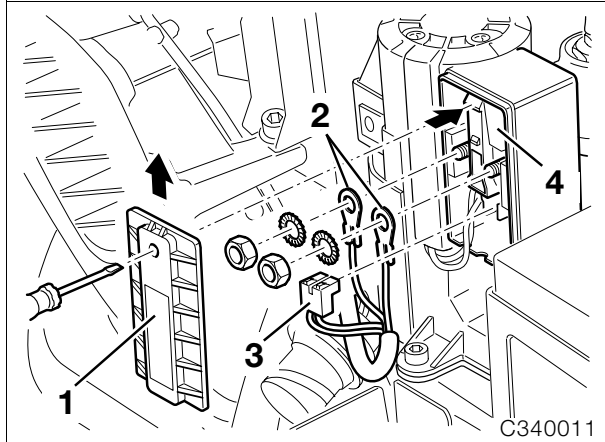

Caution:

Switch off ignition, disconnect and insulate the ground (earth) strap.

- Remove cover (1) from ABS control unit, press in the lock with a screwdriver and pull the cover up.
- **Scrap** the old cover (1).
- Detach lines (2) and **discard** nuts.

Caution:

Make sure the cable is not at an angle, or its insulation may be damaged.

- Pull off 2-pin plug (3).
- Take out relay base (4).
- **Slacken off** screws on relay base by app. 2 turns with **Torx T20**.
- Pull the relay off upwards.

Installing the ABS relay

- Insert the ABS relay with the FAG inscription facing the detent hook.
- Tighten the screws at the relay base.
- Push the relay base into the relay housing, at the same time pressing both engine cables into the left cable entries on the relay housing (red at bottom, black at top).
- Attach black engine cable to left threaded pin (M5) with crimp at back.

Caution:

Make sure the cable is not at an angle, or its insulation may be damaged.

- Reconnect the 2-pin plug in the correct position, pushing the two halves fully together, and press the two wires into the center (smaller) cable entries.
- Push the two plugs for the connecting cable/wiring harness onto the threaded pins with the crimp at the front.
- Press the two cables into the remaining free cable entries.

- Tighten the nuts.



Caution:

Always use new self-locking nuts.

- Install a new cover (1).



Caution:

When sliding the cover on, make sure that all cables are correctly located in their cable entries. **Scrap** the old cover.

Removing ABS relay base



Caution:

Switch off ignition, disconnect and insulate the ground (earth) strap.

- Remove cover (1) from ABS control unit, press in the lock with a screwdriver and pull the cover up.
- **Scrap** the old cover (1).
- Detach lines (2) and **discard** nuts.



Caution:

Make sure the cable is not at an angle, or its insulation may be damaged.

- Pull off 2-pin plug (3).
- Take out relay base (4).
- Remove screws at relay base with **Torx T20**.
- Remove the ABS relay.
- Press the contact interlock out of the relay base.
- Release the plug from the relay side using special tool **No. 50000-017-507 from the Grote und Hartmann company**.



Caution:

The contact has a double detent.

When pulling the plug out of the relay base, avoid applying too much tension to the cable.

If the cable breaks, the complete ABS unit will have to be exchanged.

Installing the ABS relay base

- Bend up the contact interlock on the plug.
- Insert the contact into the relay base.



Caution:

The contact must be heard to engage and must be firmly located.

- Insert the ABS relay with the FAG inscription facing the detent hook.
- Insert a Torx screw into the ring shoe of the red engine cable.



Note:

The crimp side is towards the screw head.



Caution:

The same Torx screws must be re-used because of their self-locking effect.

When inserting the screws again, make sure that they pick up with the existing thread in the sheet-metal element.

Failing this, vibration could cause the screws to work loose.

- Place the ring shoe (with two cables) on the bore of the insert at the rear of the relay base, with the crimp side towards the relay base, and screw on together with the red engine cable, using the Torx screw.
- Use the second Torx screw to secure the flat plug to the relay.
- Press the contact interlock into the relay base at the side.
- Push the relay base into the relay housing, at the same time pressing both engine cables into the left cable entries on the relay housing (red at bottom, black at top).
- Attach black engine cable to left threaded pin (M5) with crimp at back.



Caution:

Make sure the cable is not at an angle, or its insulation may be damaged.

- Reconnect the 2-pin plug in the correct position, pushing the two halves fully together, and press the two wires into the center (smaller) cable entries.
- Push the two plugs for the connecting cable/wiring harness onto the threaded pins with the crimp at the front.
- Press the two cables into the remaining free cable entries.
- Tighten the nuts.



Caution:

Always use new self-locking nuts.

- Install a new cover (1).



Caution:

When sliding the cover on, make sure that all cables are correctly located in their cable entries.

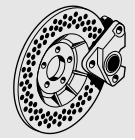

Removing and installing brake lines

Removing and installing front brake line

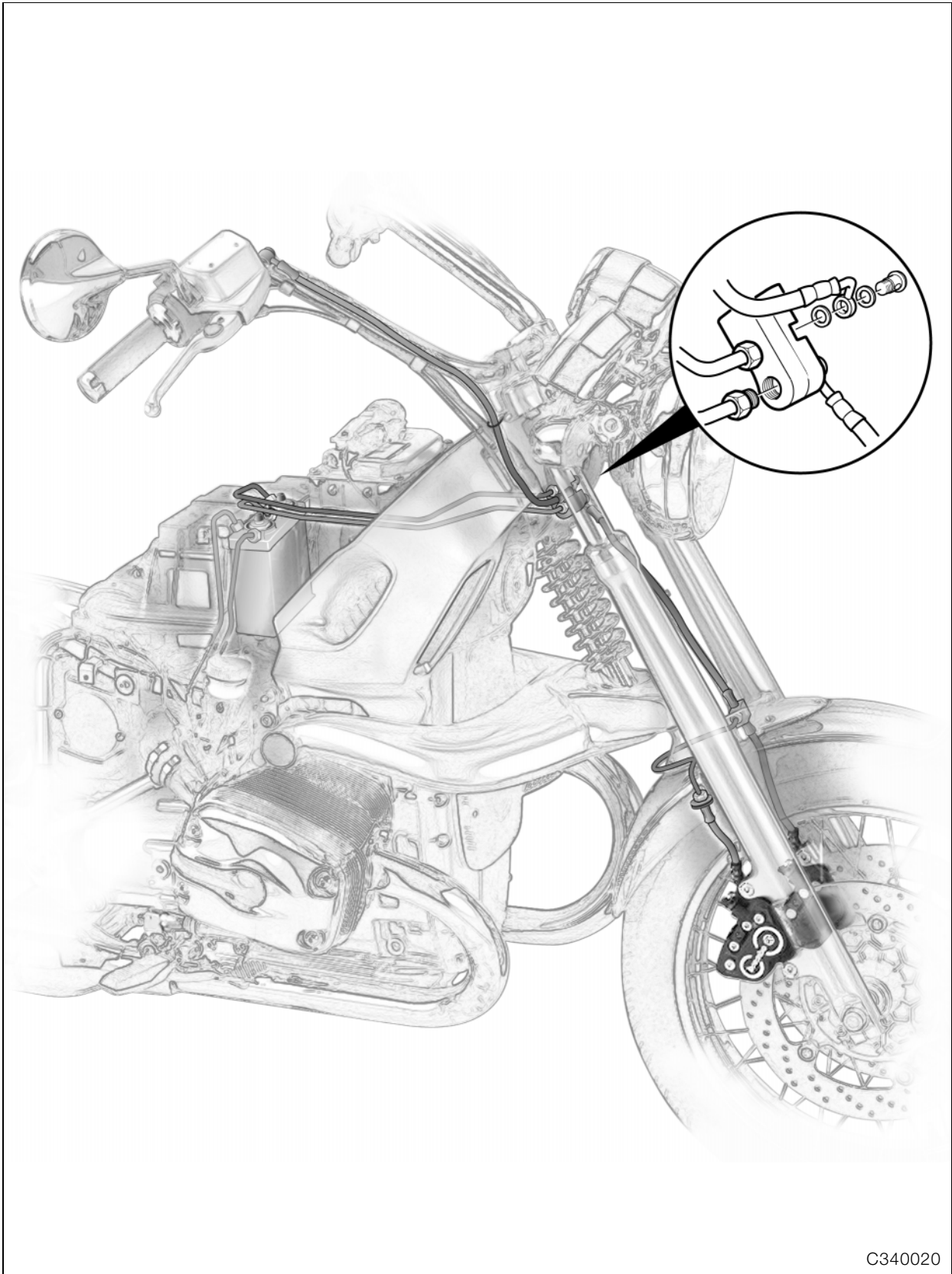
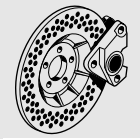

C340020

Removing and installing rear brake line

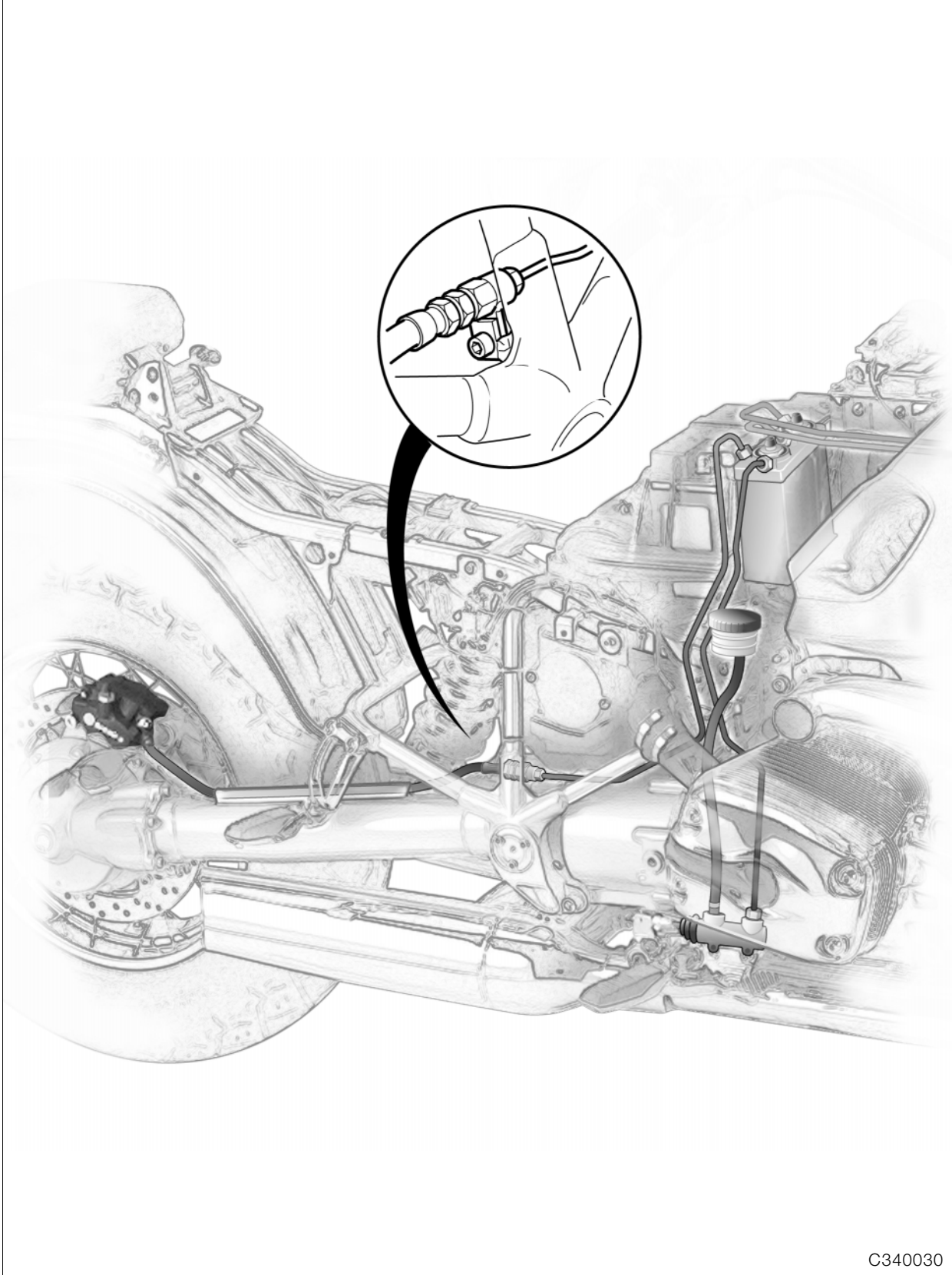

C340030

- Drain fluid from brake system.



Caution:

Do not allow brake fluid to come into contact with painted parts of the motorcycle, because brake fluid destroys paint.

- Remove fuel tank.
- Remove brake lines.
- Install by following the above work instructions in the reverse order.



Caution:

Renew sealing rings for brake line.
 Attach brake line to master cylinder so that it cannot become kinked or abraded when the handlebar is turned.
 Fill/bleed the brake system.



Tightening torque:

Brake hose and brake line.....	15 Nm
Bleed screws in front brake caliper	7 Nm
Bleed screw on rear brake caliper	4 Nm
Bleed screw on ABS unit.....	9 Nm
Junction block at front frame.....	9 Nm
Junction block to slider tube	9 Nm

36 Wheels and tyres

Contents

Page

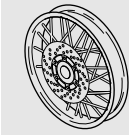

Technical data	3
Removing and installing front wheel	5
Removing front wheel	5
Installing front wheel	5
Removing and installing wheel bearings	6
Removing/installing rear wheel	8
Static balancing of front wheel/rear wheel	9
Checking front/rear wheel rim for runout	10
Removing/installing spokes	11
Centering the wheel rim	11
Centering lateral runout	11

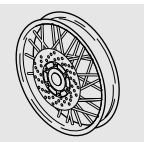

Technical data		R 850 C	R 1200 C
Rim size			
	Front	2.50 x 18 MT H 2	
	Rear	4.00 x 15 MT H 2	
Max. vertical/lateral runout	mm (in)	1.3 (0.05)	
Tyre size			
	Front	100/90 x 18 56H Tubeless	
	Rear	170/80 x 15 83H Tubeless	
Tyre pressures (cold)			
Solo	Front	bar (psi)	2.2 (31.9)
	Rear	bar (psi)	2.5 (36.3)
With pillion passenger			
	Front	bar (psi)	2.5 (36.3)
	Rear	bar (psi)	2.7 (42.0)
With pillion passenger and luggage			
	Front	bar (psi)	2.5 (36.3)
	Rear	bar (psi)	2.9 (45.1)

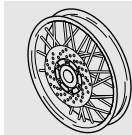

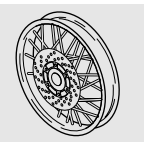

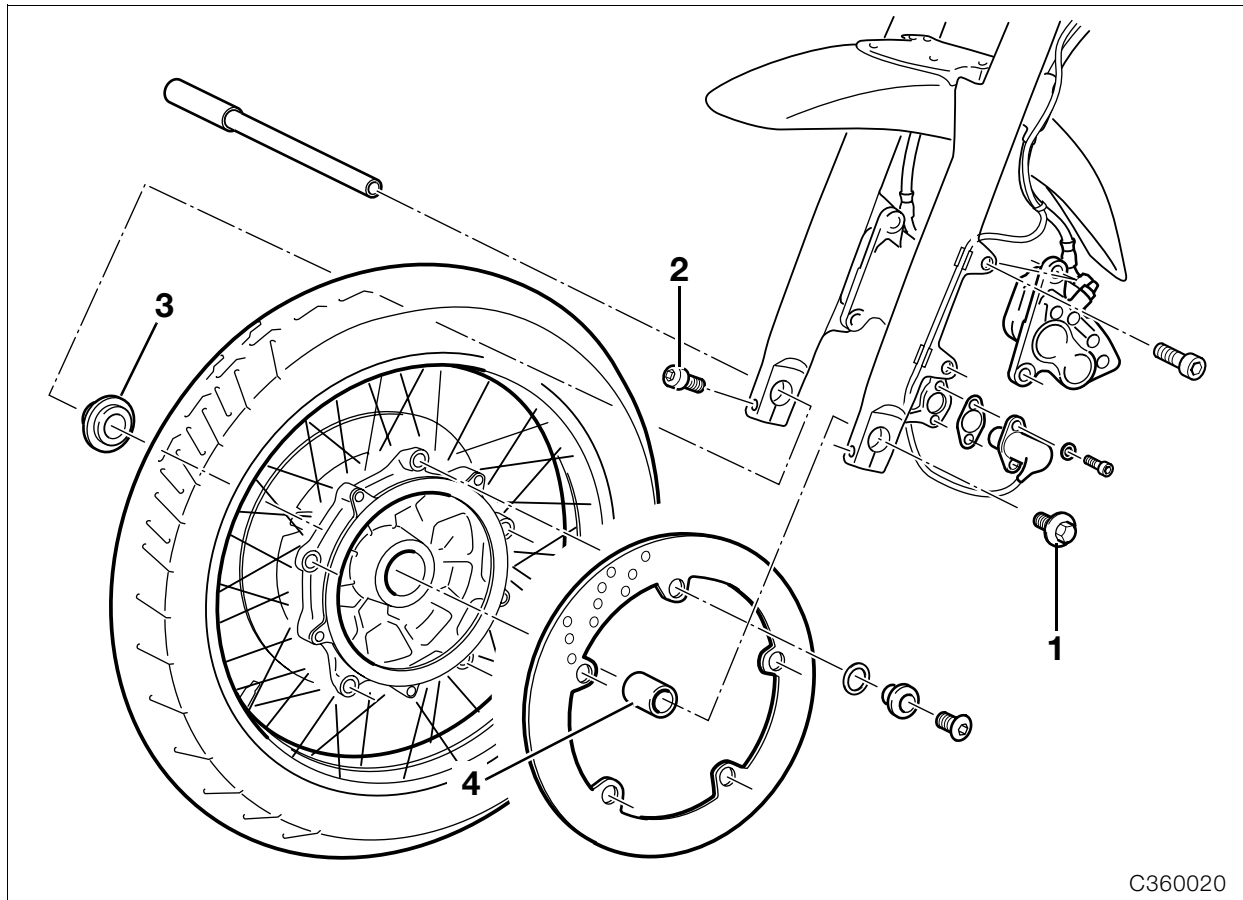

C360020

Removing and installing front wheel

Removing front wheel

- Place the motorcycle on the auxiliary stand, **BMW No. 00 1 550**.
- Remove brake calipers.



Note:

Do not apply handbrake lever with brake calipers removed/front wheel removed.

- Remove retaining screw (1).
- Loosen clamping screws (2).
- Remove quick-release axle.
- Take out spacing bushing (3/4) and front wheel.

Installing front wheel

- Install front wheel and spacing bushings.
- Apply a light coating of **Molykote paste** to the quick-release axle/install it.
- Tighten the retaining screw (1).
- Install the brake calipers.
- Compress the front fork firmly several times.
- Tighten the clamp screws (2).
- **[ABS]** Check sensor gap and adjust if necessary.

ABS sensor gap: 0.45...0.55 mm (1.77...2.22 in)



Tightening torque:

Quick-release axle threaded connection 30 Nm
 Quick-release axle clamp screws 20 Nm
 Brake caliper at fork slider tube 40 Nm

Removing and installing wheel bearings

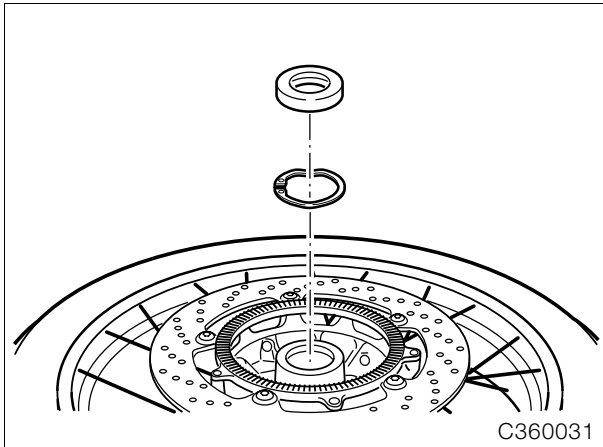

- Carefully lever out the shaft sealing ring with a screwdriver.
- Remove the circlip.

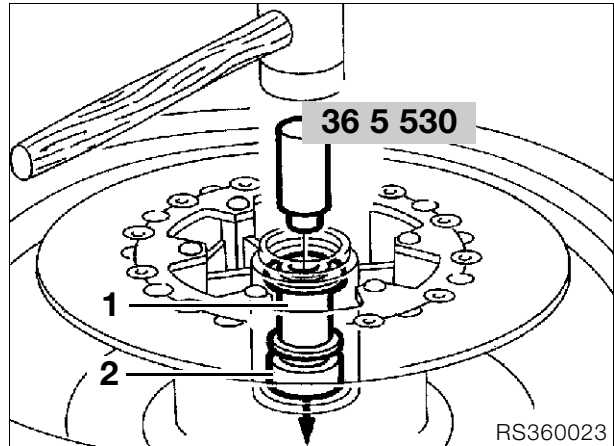

- Press out spacing bushing (1) and wheel bearing (2) with drift, **BMW No. 36 5 530**.
- Degrease bearing seats.
- Heat bearing seat to 80 °C (176 °F).

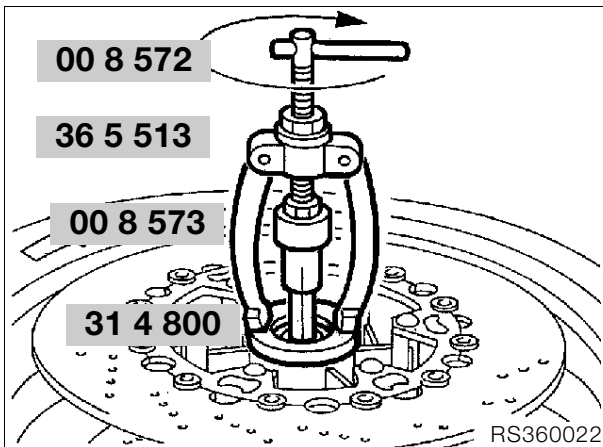

- Clamp a drift, **BMW No. 36 5 513**, into the vice and place the wheel on it with the wide bearing in contact.
- Place a spacing ring, **BMW No. 31 4 800**, between the wheel hub at the right and the claws of the internal puller.
- Heat bearing seat to 80 °C (176 °F).
- Pull out the wheel bearing with counter-support 22/1, **BMW No. 00 8 572**, and internal puller 21/4, **BMW No. 00 8 573**.

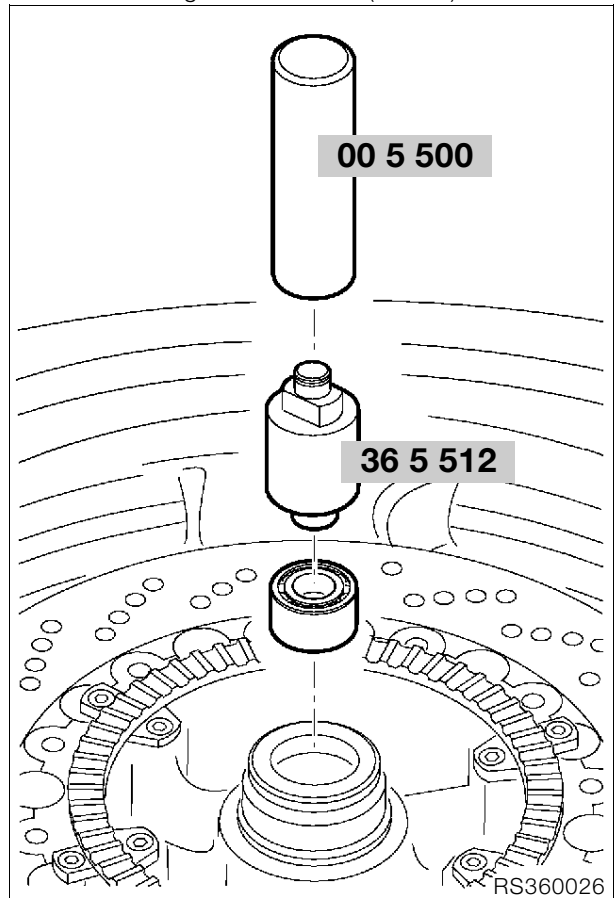

- **First** insert wide bearing using drift, **BMW No. 36 5 512**, and handle, **BMW No. 00 5 500**.

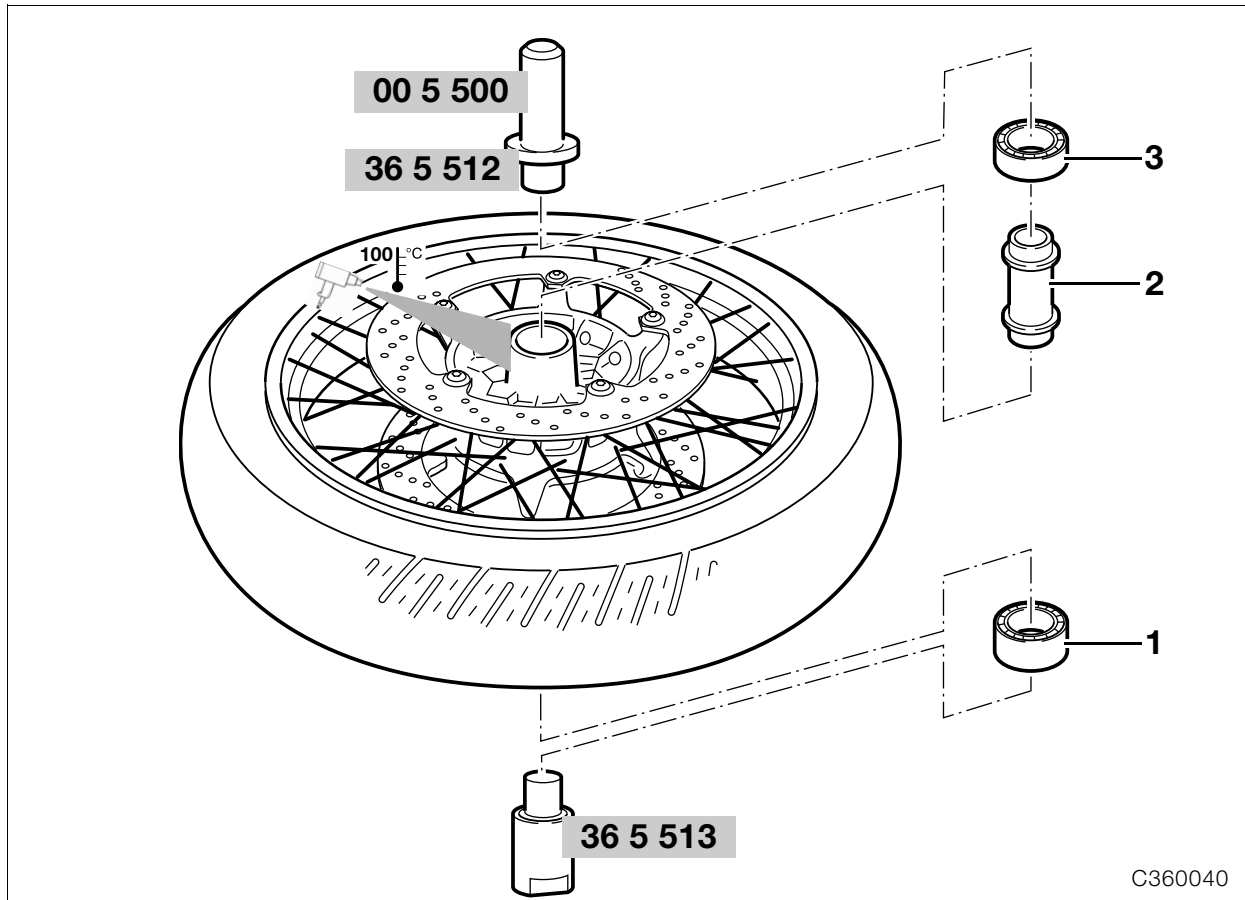

- Clamp a drift, **BMW No. 36 5 513**, into the vice and place the wheel on it with the wide bearing (1) in contact.
- Install spacer tube (2).
- Bearing seat temperature 80 °C (176 °F).
- Insert narrow bearing (3) with drift, **BMW No. 36 5 512**, and handle, **BMW No. 00 5 500**.

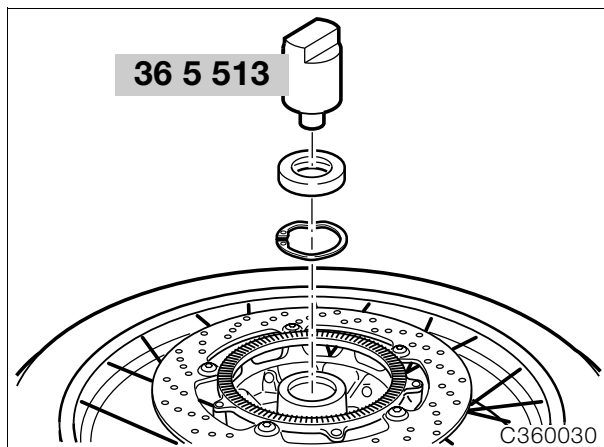

- Install circlip with convex side facing down.
- Drive in shaft sealing ring with drift, **BMW No. 36 5 513**.

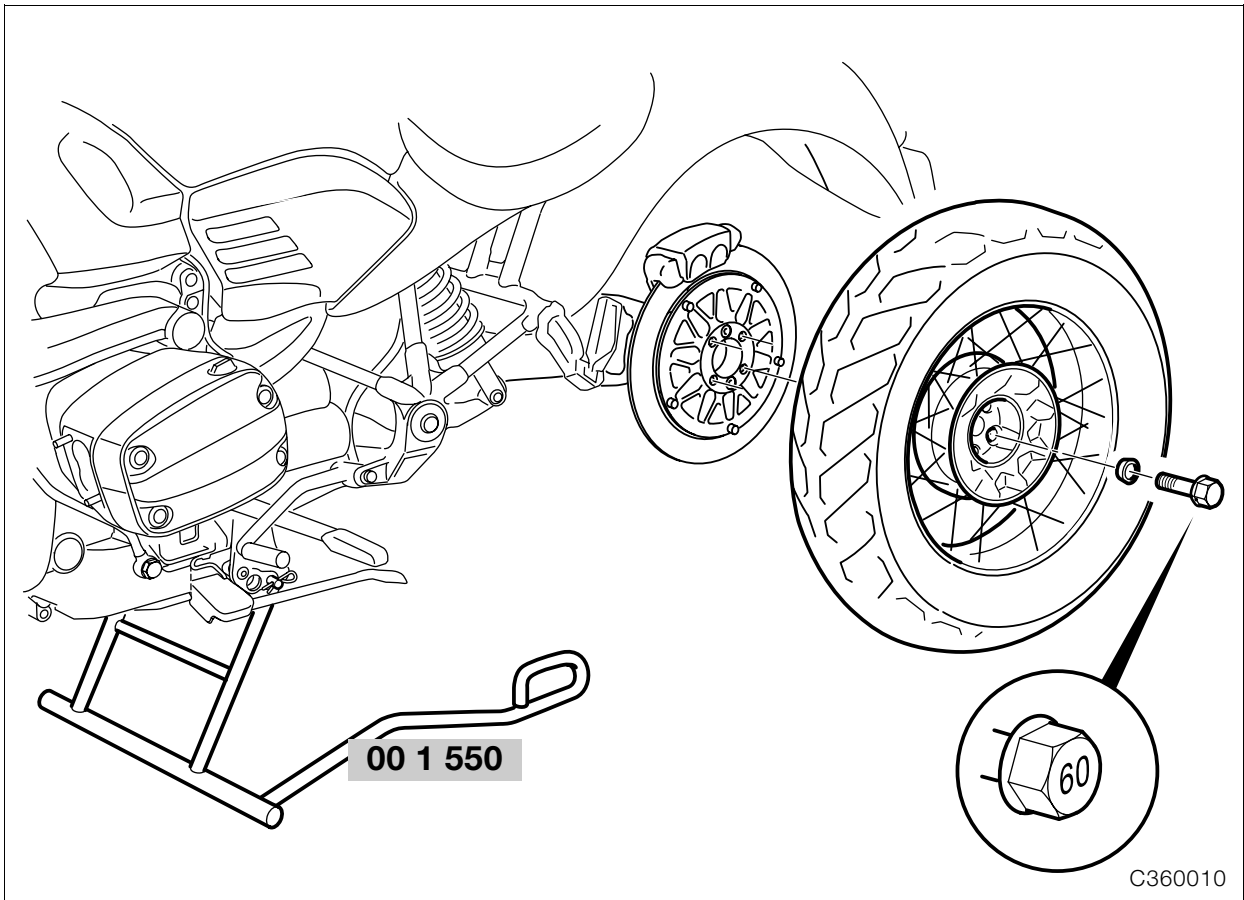

Removing/installing rear wheel

- Place the motorcycle on the auxiliary stand, **BMW No. 00 1 550**.



Caution:

Only use wheel studs with length code 60.
Do not oil or grease wheel studs!
Contact faces on rear wheel drive and hub must be clean and free of grease.



Tightening torque:

Screw in wheel studs handtight, then tighten them in a crosswise pattern

Initial tightening	50 Nm
Final tightening	105 Nm

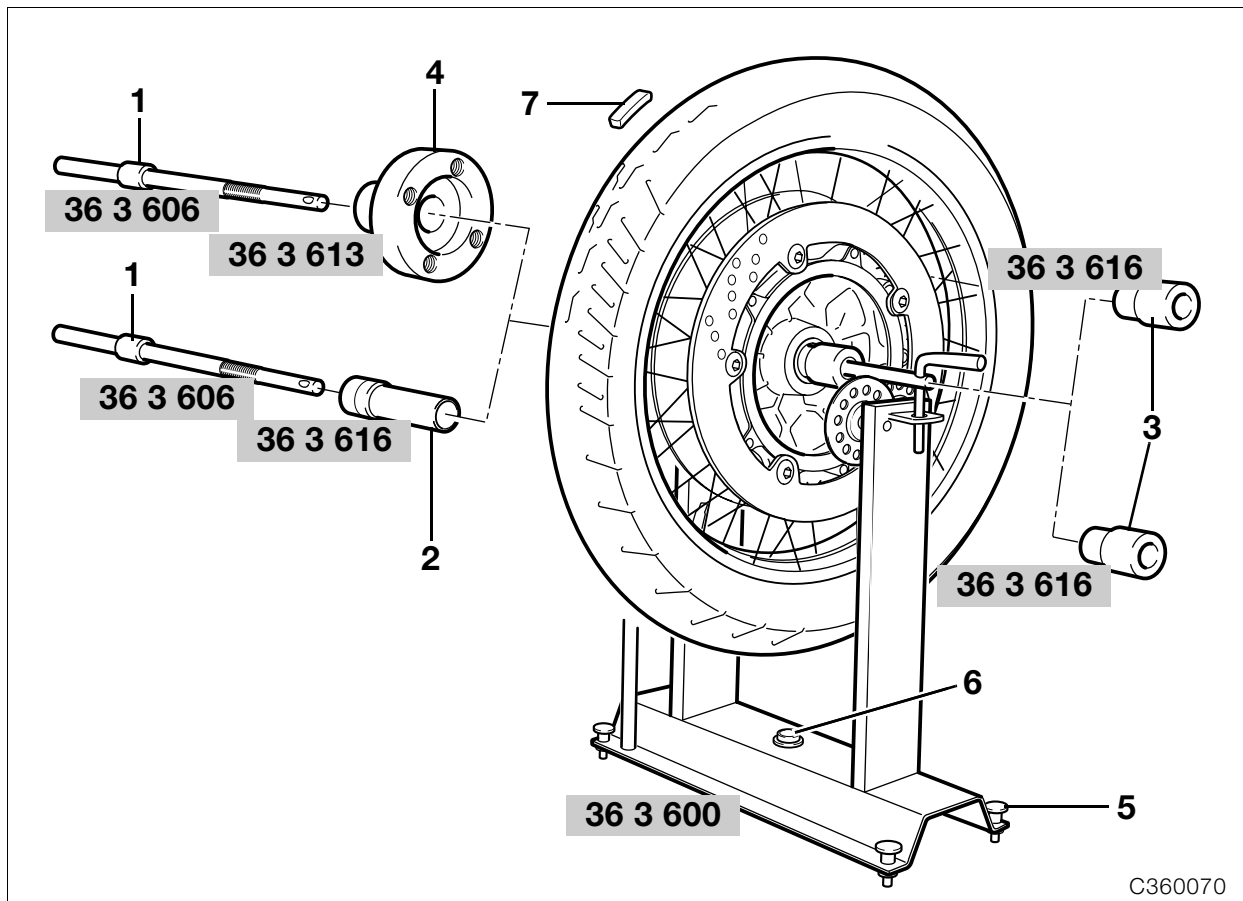

Static balancing of front wheel/rear wheel

- Install balancing shaft (1), **BMW No. 36 3 606**, with measuring bushing (2) and nut (3), **BMW No. 36 3 616**, in front wheel bearings.
- Lightly preload bearing with knurled nut (3).
- At the rear wheel, bolt the mounting fixture (4), **BMW No. 36 3 613**, to the centering collar side with the balancing shaft.
- Align the balancing fixture, **BMW No. 36 3 600**, with knurled screws and bubble gauge (5/6).
- Allow wheel to settle.
- Clean points of adhesion for balance weights.
- Attach adhesive weights (7) opposite the heaviest point on both sides of the wheel rim, with the total weight equally divided between the left and right sides.



Caution:

Maximum balancing weight 60 g (2.12 oz).

- Repeat the balancing procedure as a check.

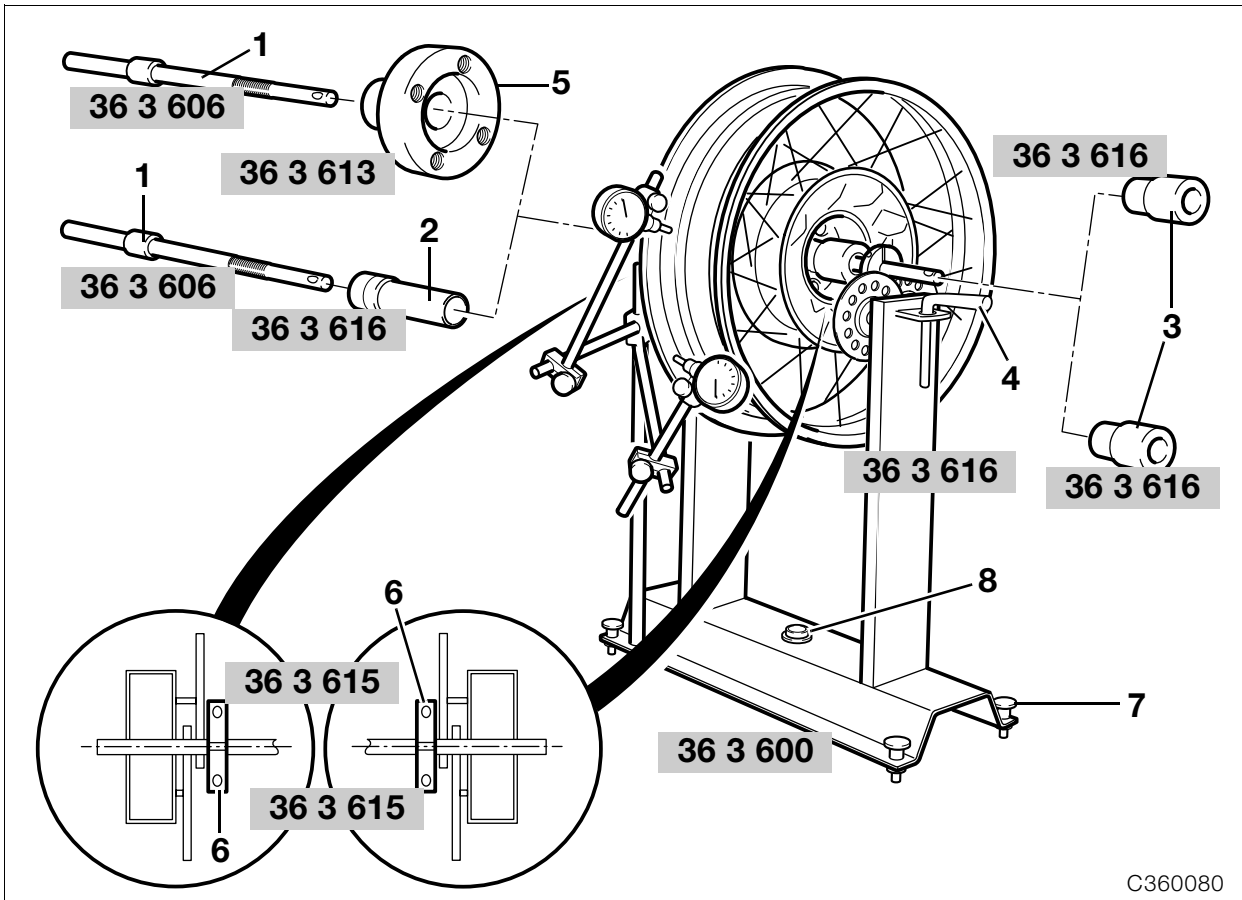

C360080

Checking front/rear wheel rim for runout

- Remove tyre.
- Install the balancing shaft (1), **BMW No. 36 3 606**, with measuring bushing (2) and nut (3), **BMW No. 36 3 616**, in the front wheel bearings.
- Lightly preload bearing with knurled nut (3).
- Use pin (4) to lock the balancing shaft against the balancing stand to prevent the shaft from turning.
- At the rear wheel, attach mounting fixture (5), **BMW No. 36 3 613**, on the centering collar side with the wheel studs, then install the balancing shaft.
- Clamp locating discs (6), **BMW No. 36 3 615**, to the balancing shaft at left and right in such a way that the shaft cannot wander.
- Align the balancing fixture, **BMW No. 36 3 600**, with the knurled screws/bubble gauge (7/8).
- Check radial/axial runout.



Caution:

Only apply dial gauge to machined inner face of wheel rim.

Max. vertical runout/horizontal runout

..... 1.3 mm (0.05 in)

Removing/installing spokes

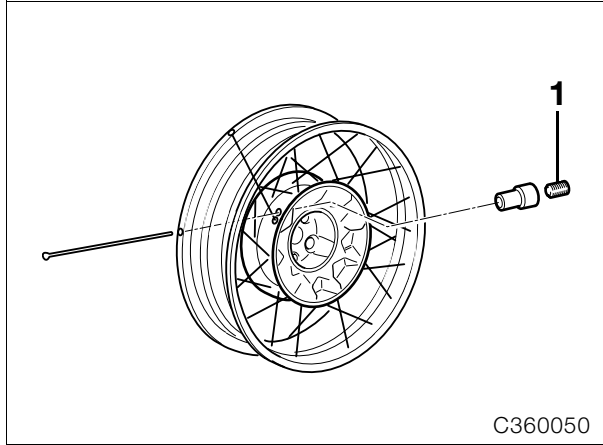

Caution:

It is not permitted to replace more than one spoke.

- Unfasten grub screw (1).
- Loosen the spoke nipple/remove the spoke.
- Install new spoke.
- Center the wheel rim.



Tightening torque:

Spoke nipple 5 Nm

Centering the wheel rim

Max. permissible lateral/vertical runout 1.3 mm (0.05 in)
Max. horizontal runout which can be eliminated by centering 2.0 mm (0.08 in)



Note:

Vertical runout cannot be compensated for by centering the rim.

Centering lateral runout

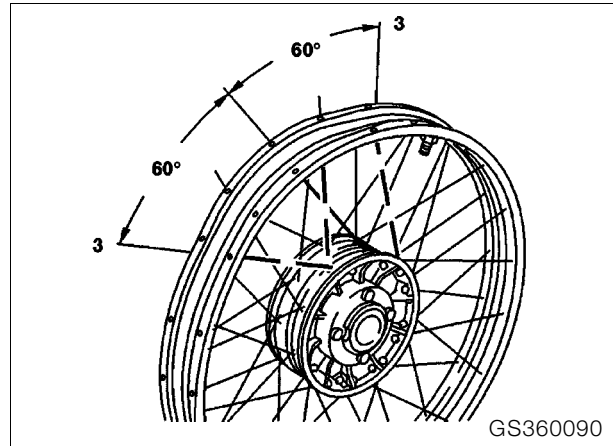

- Determine maximum deviation (plus (+) and minus (-)).
- To center the wheel, the spoke nipples must be tightened on the side directly opposite the largest deviation.
- Remove grub screw from relevant spoke nipple before tightening.
- Working forwards and backwards from the maximum and minimum value points, take up slack at every third spoke nipple.



Caution:

Never attempt to compensate for the entire horizontal runout at only one or two spokes.

- At the point where the maximum plus and minus values occur, take up slack at 2 spokes.
- Four spokes are therefore tightened during each centering operation.
- Check horizontal runout with a dial gauge.
- After every correction of horizontal runout, check vertical runout again.
- If necessary, repeat the centering operation.
- Lock tightened spokes into place with grub screws.



Tightening torque:

Spoke nipple 5 Nm
 Grub screw 1 Nm

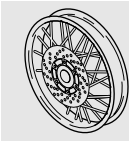

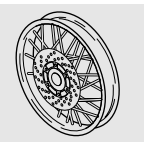

46 Frame

Contents

Page

Technical data	3
Removing and installing rear mudguard	5
Removing/installing front mudguard	5
Removing and installing front frame	6
Removing and installing rear frame	8
Removing/installing footrest supports	10
Removing and installing side (prop) stand	10
Checking running gear	11
Measuring wheel track offset	11





Technical data		R 850 C	R 1200 C
Location of manufacturer's type plate / frame number		On frame, at right	
Length, overall	mm (in)	2340 (92.1)	
Max. height excl. mirrors	mm (in)	1130 (44.5)	
Width over mirrors	mm (in)	1050 (41.3)	
Width over rider's footrests	mm (in)	665 (26.2)	
Width over pillion footrests	mm (in)	585 (23.0)	
Height of seat at unladen weight	mm (in)	740 (29.1)	
Wheelbase in normal-load position	mm (in)	1650 (65.0)	
Ground clearance at unladen weight	mm (in)	172 (6.77)	
Caster angle in normal-load position	mm (in)	86 (3.36)	
Steering head angle in normal-load position	°	60.5	
Max. wheel track offset	mm (in)	9 (0.35)	
Unladen weight, ready for road, full tank	kg (lbs)	256 (564)	
Axle load distribution (without rider), front/rear	kg (lbs)	126/130 (278/287)	
Permissible wheel loads			
front	kg (lbs)	190 (419)	
rear	kg (lbs)	260 (573)	
Permitted gross weight	kg (lbs)	450 (992)	





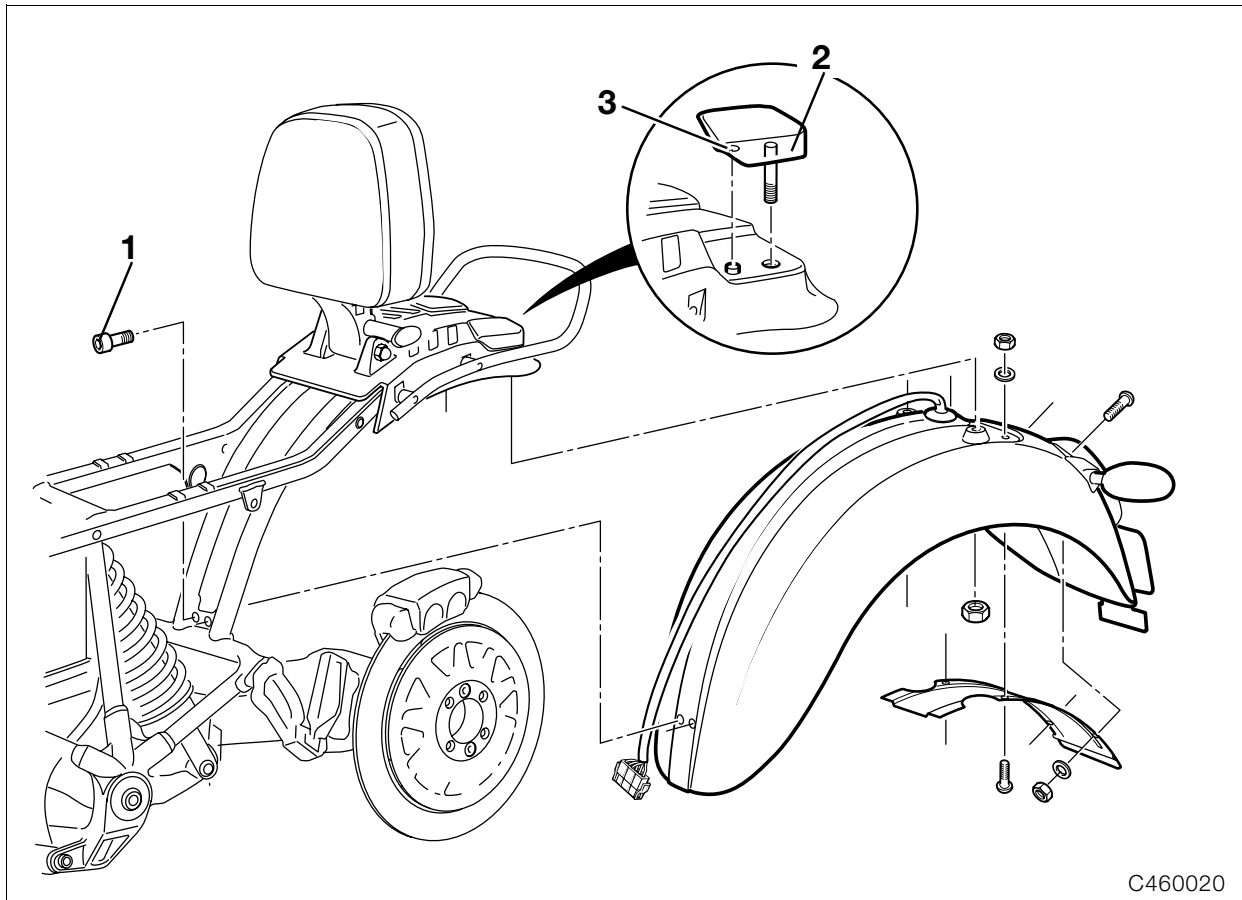

C460020

Removing and installing rear mudguard

- Take out the front retaining screws (1)
- Remove the nuts at the rubber cover (2)



Caution:

The locking lug (3) of the retaining elements must engage in the hole.
If necessary, bend the retaining element.

Removing/installing front mudguard

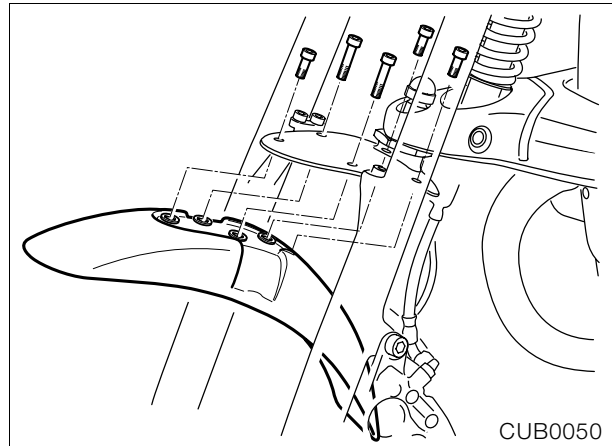

CUB0050



Tightening torque:

Mudguard to slider tube bridge 8 Nm

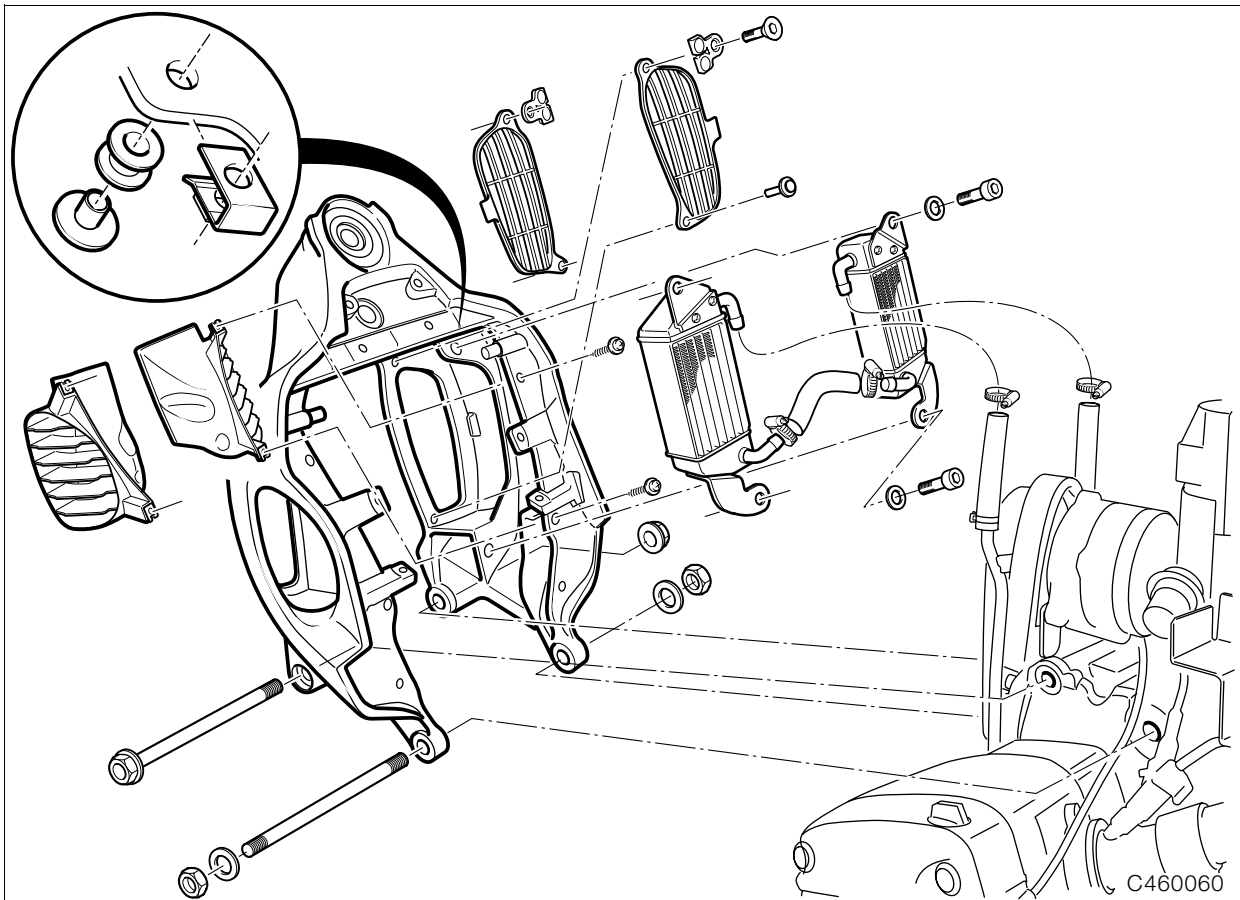

Removing and installing front frame

- Remove seat.
- Remove side trim.
- Remove fuel tank.

Caution:

Switch off ignition.
Disconnect earth (ground) lead from battery.
Insulate earth (ground) lead.

- Detach the Motronic control unit.
- Unplug the wires in the central electrical equipment box.
 - Instruments
 - Right combined switch
 - Left combined switch
 - Front brake light switch
 - Clutch switch
 - Front ABS sensor
- Detach the cable straps from the wiring.
- Detach the central electrical equipment box.
- Unplug the ignition leads at the coil.
- Remove the coil.
- Disconnect the throttle cable at the twistgrip.
- Drain fluid from brake system.
- Drain the clutch operating system.
- Separate the clutch line where it passes through the frame.
- Detach the brake hose at the junction block/frame.
- Detach the brake lines at the junction block/frame.
- Detach the junction block at the frame.
- Attach the engine holder.

- Heat the ball joint mount at the leading link to max. 120 °C (248 °F) and detach it.

Caution:

Avoid scratching the leading link.

- Pull the leading link off its pivots and pull the telescopic fork forwards.
- Remove the suspension strut mount trim panel upwards.
- Remove suspension strut.
- Remove headlight.
- Unplug and remove the flashing turn indicators.
- Remove handlebar.
- Loosen screw for cap at fork bridge mount on frame.
- Use an M6 screw with a thread length of at least 25 mm (0.98 in) to force off the cap at the fork bridge mount on the frame.
- Before removing the threaded bearing journal at the fork bridge, heat it to max. 120 °C (248 °F), unscrew it and remove the telescopic fork.

Note:

The screw pin is a press fit in ball thrust bearing: remove as a complete unit.

- Detach the left air intake pipe from the cylinder head.
- Remove the leading link caps.
- Remove the left screw cap.
- Remove the circlip at the right and take off the retaining cap.
- Take out the screw at the right and pull the axle out to the left.
- Remove the leading link.

- Remove the horn.
- Remove the air guides to the oil cooler.
- Remove the oil cooler.
- Remove frame.



Note:

Only loosen the threaded connections at the lower rear frame.

- Install by following the above work instructions in the reverse order.



Tightening torque:

Fork bridge to frame
 (clean thread + Loctite 243)..... 130 Nm
 Threaded connections between frame and engine
 Front 82 Nm
 Rear 58 Nm



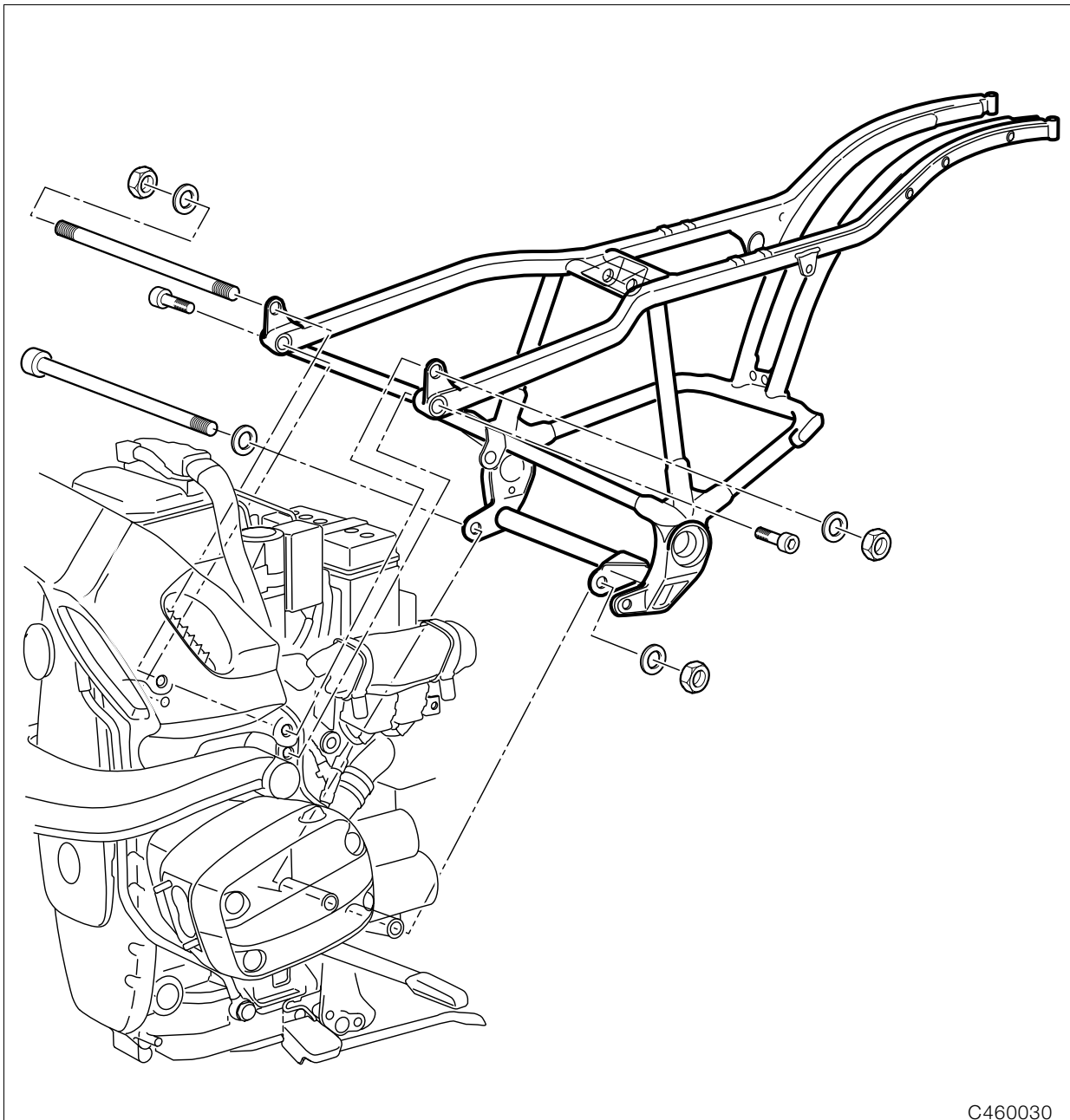

C460030

Removing and installing rear frame

- Attach stand to motorcycle with extension bushings, **BMW No. 00 1 520/529**.
- Remove seat.
- Remove side trim.
- Remove fuel tank.



Caution:

Switch off ignition.
Disconnect earth (ground) lead from battery.
Insulate earth (ground) lead.

- Remove rear wheel.
- Detach rear brake caliper.
- Detach ABS sensor.
- Detach speedometer signal transmitter.
- Detach brake line cover on swinging arm.
- Tie the swinging arm up to the frame with a strap.

- Remove suspension strut.



Note:

Press to the rear at the top.

- Pull the swinging arm up with the strap.
- Remove silencer (muffler).



Note:

Alternately strike the silencer (muffler) rearwards with the palm of the hand or pull it.

- Disconnect the oxygen sensor plug.
- Remove rear wheel drive unit.

- Detach the brake hose holder

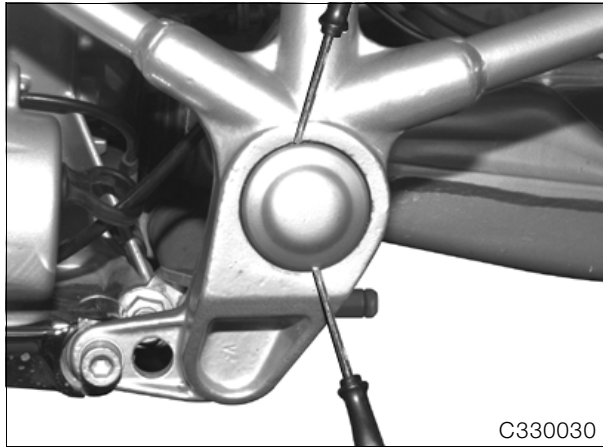

- Remove fittings.
- Install by following the above work instructions in the reverse order.

 **Tightening torque:**

Rear section of frame to engine	
Pin	58 Nm
M10 bolt.....	41 Nm
Rear section of frame to gearbox	71 Nm

- Press off the left swinging arm bearing cap.



Caution:

When installing, check that O-ring is in good condition.

- Loosen the left swinging arm bearing.
- Loosen screws for right swinging arm bearing.

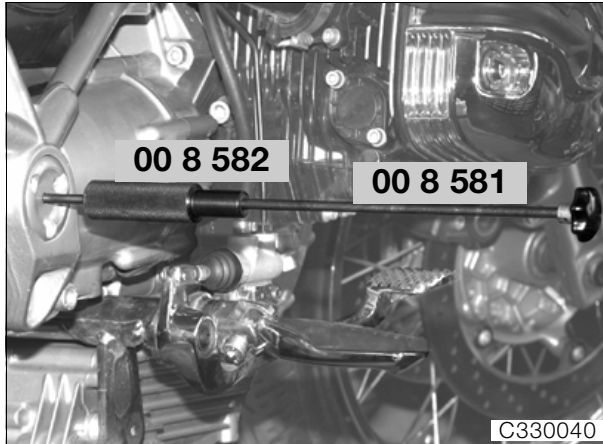

- Using pull rod, **BMW No. 00 8 581**, and impact weight, **BMW No. 00 8 582**, pull out the swinging arm bearing.
- Remove the left swinging arm bearing.
- Remove rear swinging fork.
- Remove rubber sleeves for intake air pipes.
- Pull brake fluid reservoir out of holder.
- Remove the holder.
- Detach the right plug retaining plate.
- Pull off the air temperature plug.
- Detach the gear lever.
- Separate the throttle potentiometer and throttle positioner plugs at the left plug retaining plate.
- Detach both fuse boxes at the plug retaining plate.
- Separate the side (prop) stand switch plug.
- Separate the neutral indicator switch plug.
- Detach the left plug retaining plate.
- Remove the injectors.
- Pull off the injector line plugs.
- Detach the breather hose at the air cleaner casing.
- Disconnect the brake light switch plug and detach the cable.
- Detach the air cleaner casing.
- Remove rear section of frame.



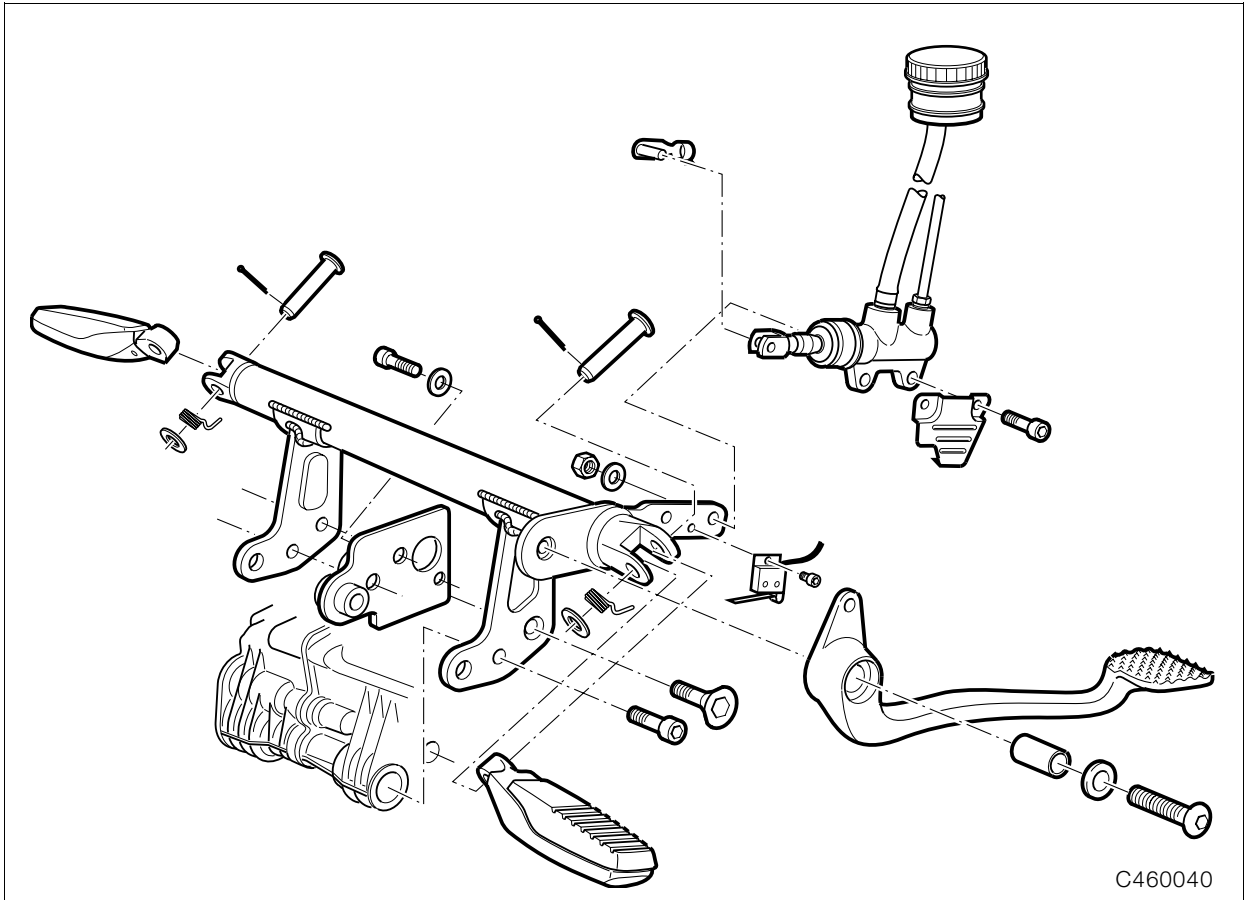

C460040

Removing/installing footrest supports

-  **Tightening torque:**
- Footrest support to engine
 - M12 bolt..... 71 Nm
 - M8 bolt..... 21 Nm
 - Brake master cylinder to footrest assembly.... 8 Nm
 - Brake pedal to footrest assembly..... 37 Nm

Removing and installing side (prop) stand

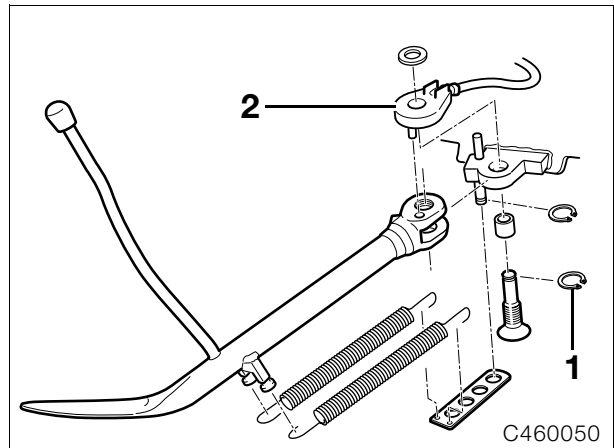

C460050

- Remove keeper (1) from side (prop) stand switch.
- Pull off side (prop) stand switch (2).
- Disconnect tension springs.
- Remove side (prop) stand.

 **Caution:**
Note wiring paths.

Lubricant:..... e.g. Staburags NBU 30 PTM

-  **Tightening torque:**
- Side stand to pivot mount
(clean thread + Loctite 243)..... 42 Nm

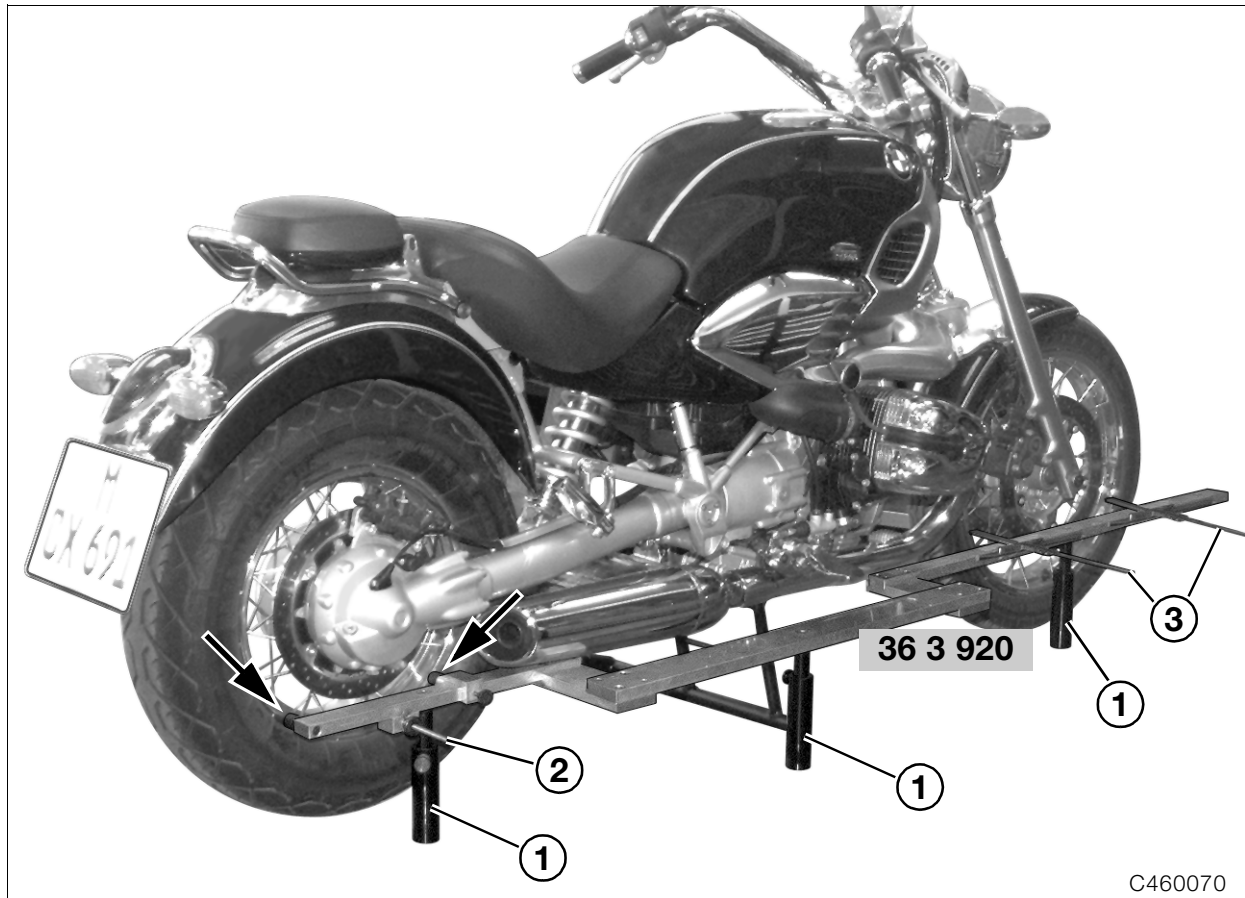

C460070

Checking running gear

Measuring wheel track offset

- Place motorcycle on level ground on centre stand.
- Place track alignment gauge, **BMW No. 36 3 920**, against the left or right side of the motorcycle.



Note:

In order to use the track alignment gauge on either the left or right side, simply screw the supports in on the other side.

- Adjust support (1) so that the measuring plane is as close as possible to the wheel centreline. The gauge must slide freely up to the motorcycle.
- Adjust measuring stops (arrows) until they contact the rim - not the tyre.
- Attach hook (2) to wheel spoke to secure the gauge firmly to the wheel.
- Align front wheel parallel with the gauge.
- Measure distance between outer edge of gauge and wheel rim, using depth gauge (3) or ruler, and make a note of the dimension.

- Calculate wheel track offset S:
- Wheel track offset S is the distance to left or right between the longitudinal axes of the front and rear wheels.

Permissible

wheel track offset (S): 9 mm (0.35 in)

Key to measurement result:

Minus sign = track offset to left

Plus sign = track offset to right

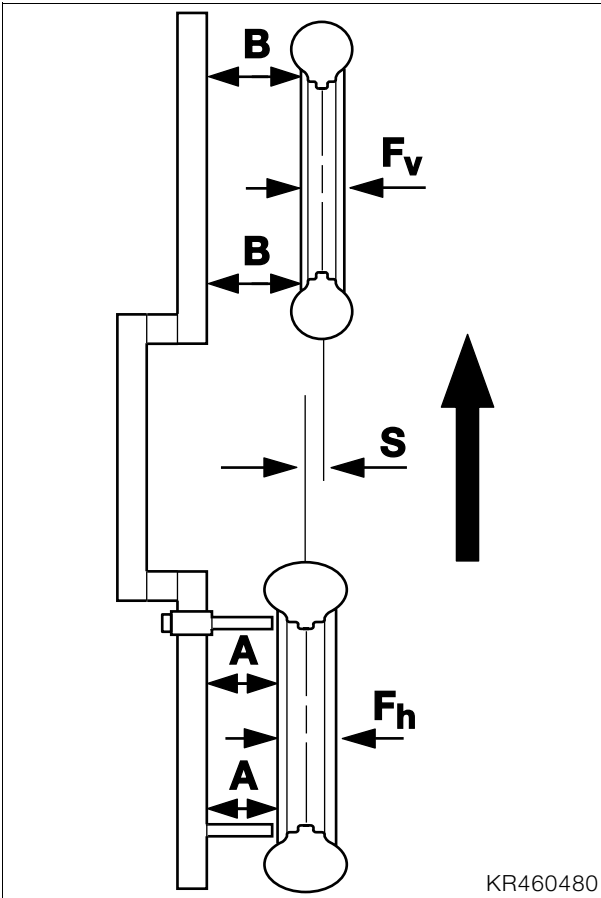

EXAMPLE:

$$\text{Formula: } S = A + \frac{F_h}{2} - \left(B + \frac{F_v}{2} \right)$$

Fixed value A
(length of measuring stops)

A = 50.0 mm (1.97 in)

Half of rear wheel rim width

$$\frac{F_h}{2} = 72.5 \text{ mm (2.85 in)}$$

Measured value B
(mean value)

B = 70.0 mm (2.76 in)

Half of front wheel rim width

$$\frac{F_v}{2} = 54.5 \text{ mm (2.16 in)}$$

Track offset S

$$S = A + \frac{F_h}{2} - \left(B + \frac{F_v}{2} \right)$$

S = 122.5 mm – 124.5 mm (4.82 in – 4.92 in)

Track offset S = – 2.0 mm (– 0.10 in)

51 Equipment

Contents

Page

Removing and installing ignition switch/steering lock	3
Removing and installing ignition/light switch	3
Removing and installing lock barrel	3
Drilling out lock barrel	3
Removing and installing lock barrel for fuel tank filler cap	4
Drilling out lock barrel	4



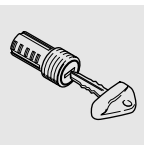

Removing and installing ignition switch/steering lock

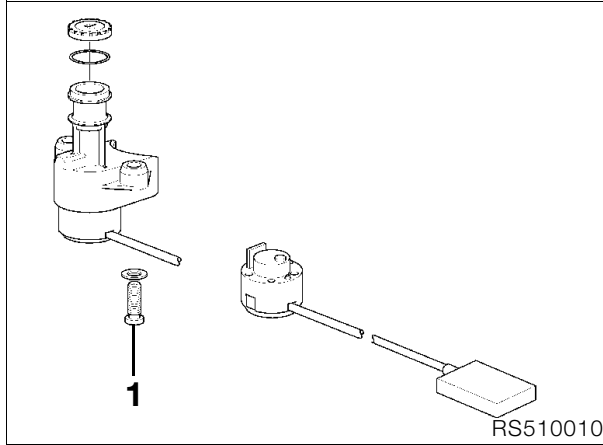

- Remove fork bridge.
- With a 4 mm (0.16 in) dia. drill bit, drill about 5 mm (0.20 in) deep into serrated screw (1).
- Use an 8 mm (0.31 in) dia. drill bit to drill away the screw head.
- Pull out the ignition switch/steering lock.
- Unscrew and remove stud bolt with stud bolt extractor.
- Install steering lock with serrated-screw socket wrench insert, **BMW No. 51 0 510**.

Tightening torque:

Serrated screws
(thread cleaned + Loctite 270)..... 15 Nm

Removing and installing ignition/light switch

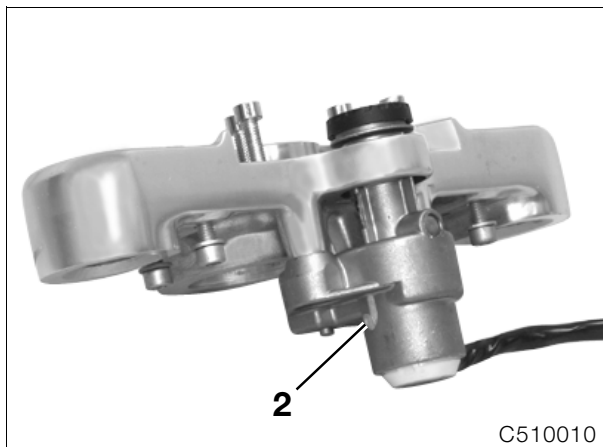

- Remove socket head cap screw (2).

Removing and installing lock barrel

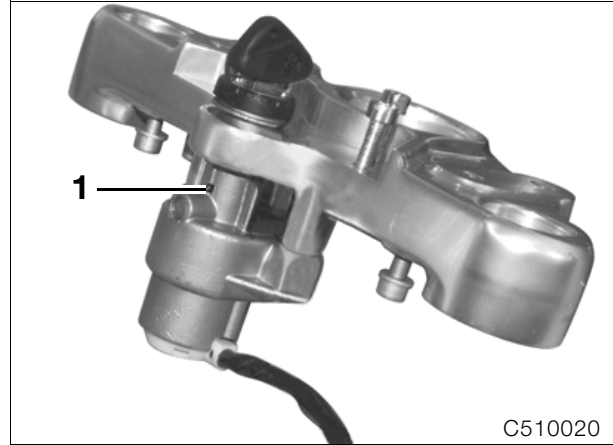

- Key in ON position/press in keeper (1) with a stiff wire or similar.
- Pull out lock barrel with key.
- Lubricate the new lock barrel with **Shell Retinax A**.
- Insert the lock barrel with the key in the ON position.
- Press lock barrel down until keeper engages.



Drilling out lock barrel

- Use a 4-5 mm (0.16-0.20 in) dia. drill bit to drill the full length of the lock barrel.
- Repeat with a drill bit of larger diameter until the lock barrel can be removed.

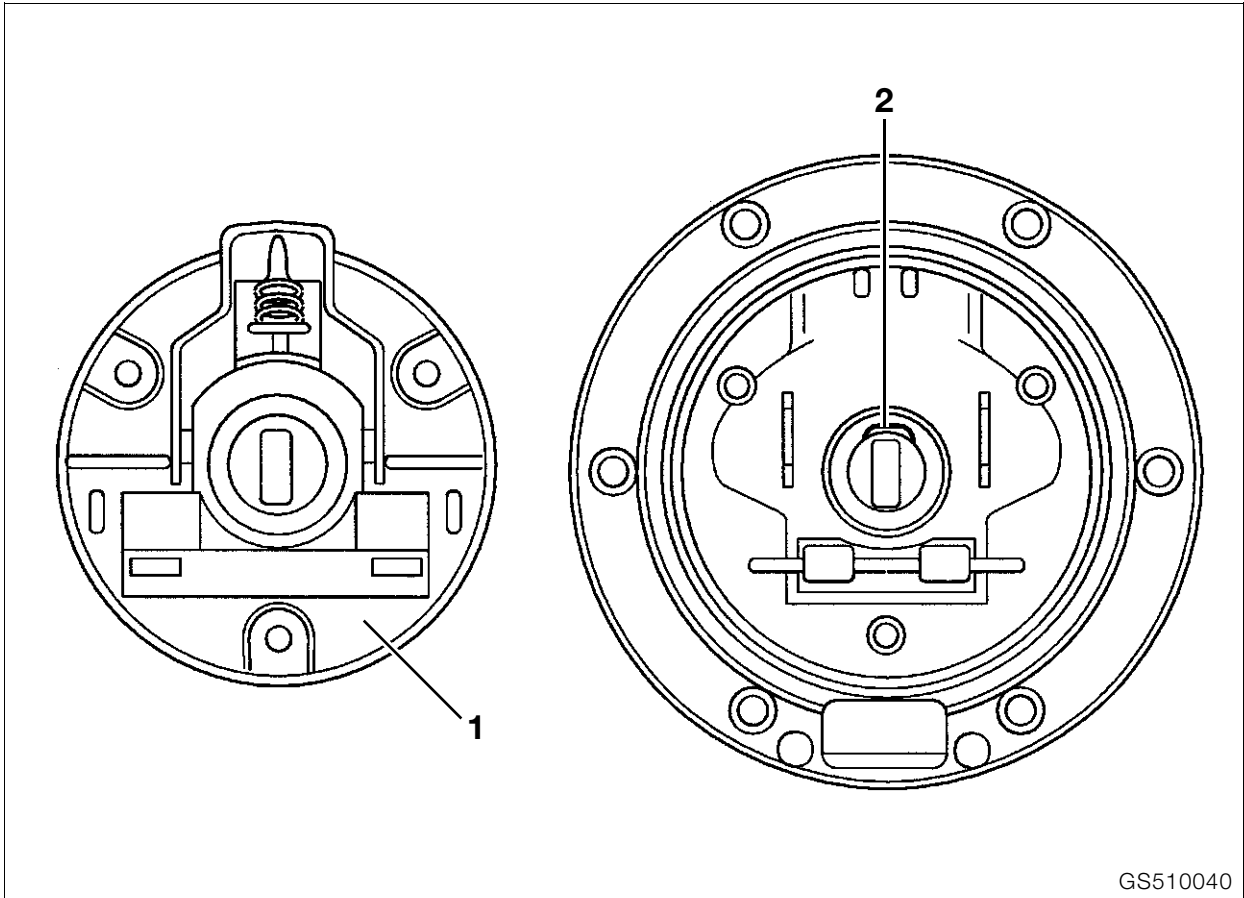

GS510040

Removing and installing lock barrel for fuel tank filler cap



Note:

Prevent screws from falling into fuel tank: cover fuel tank filler neck with cloth.

- Open cap/remove lower part of cap (1).
- Insert key in lock barrel and press down on retainer (2).
- Pull out lock barrel with key.
- Lubricate the new lock barrel with **Shell Retinax A**.
- Install lock barrel with key (at a right angle to direction of travel).
- Install by following the above work instructions in the reverse order.

Drilling out lock barrel

- Use a 4-5 mm (0.16-0.20 in) dia. drill bit to drill the full length of the lock barrel.
- Repeat with a drill bit of larger diameter until the lock barrel can be removed.

52 Seat

Contents

Page

Removing and installing seat3





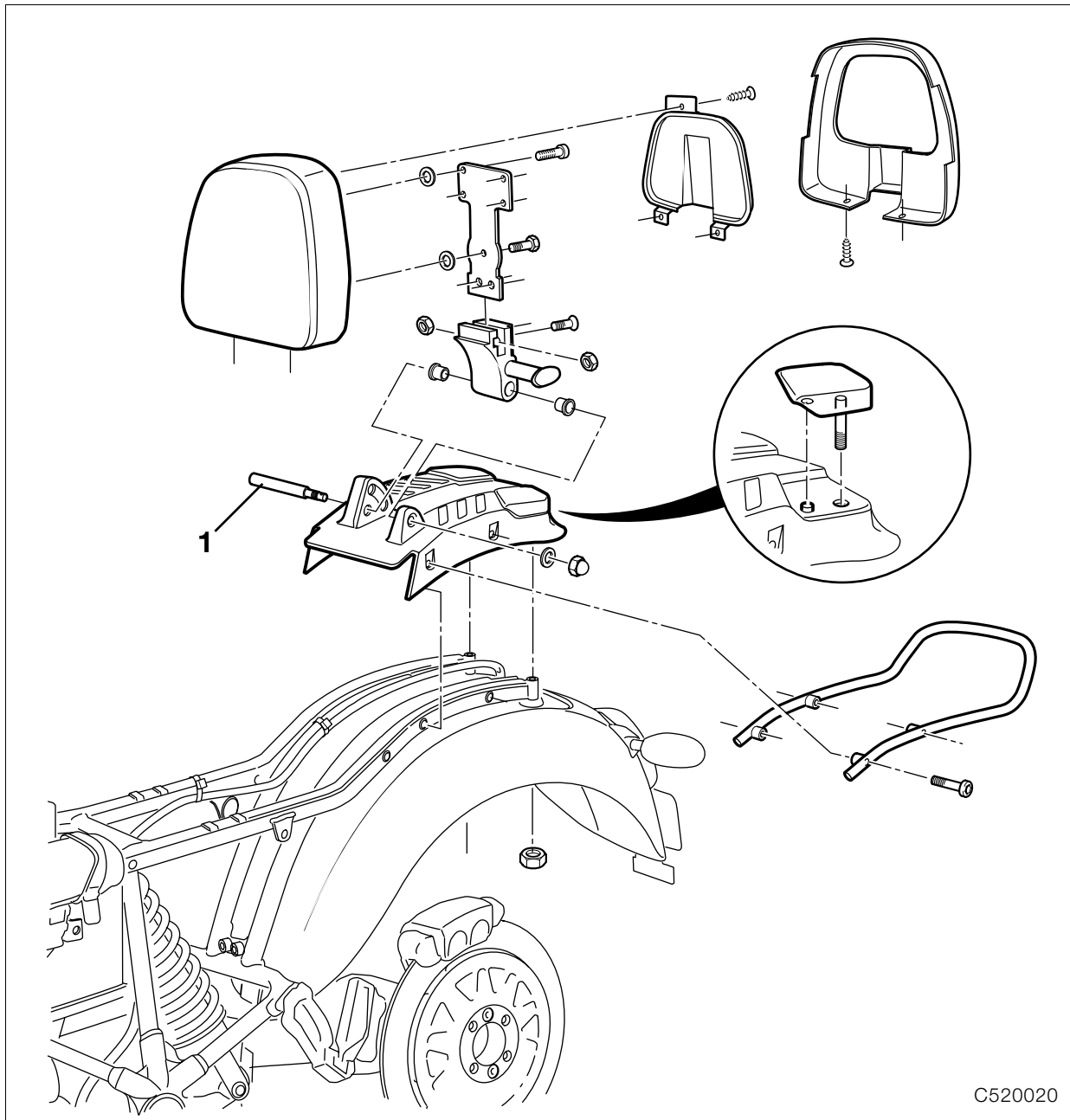

C520020

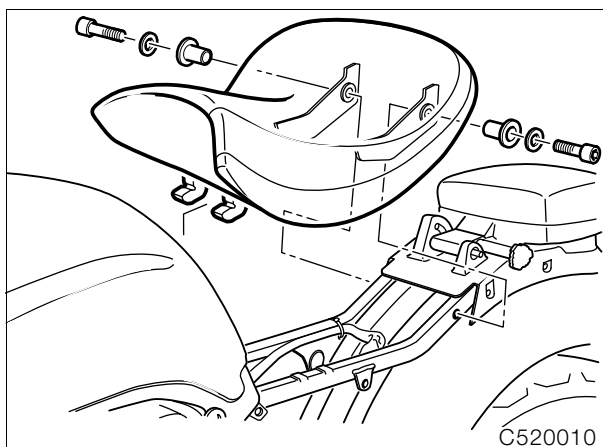

C520010

Removing and installing seat

- Take out screw (1) for seat back.
- Pull out the locking pin and take off the seat back.



61 General electrical equipment

Contents

Page

Technical data	3
Removing and installing central electrical equipment box	5
Relay positions (central electrical equipment box)	6
Connections to fuses:	6
Frame wiring harness	7
Wiring harness View from left	8
Wiring harness View from right	12





Technical data	R 850 C	R 1200 C
Battery	Amp/h	19

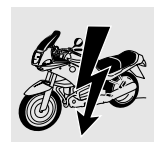



Removing and installing central electrical equipment box



Caution:

Switch off ignition.

Disconnect earth (ground) lead from battery.

Insulate earth (ground) lead.

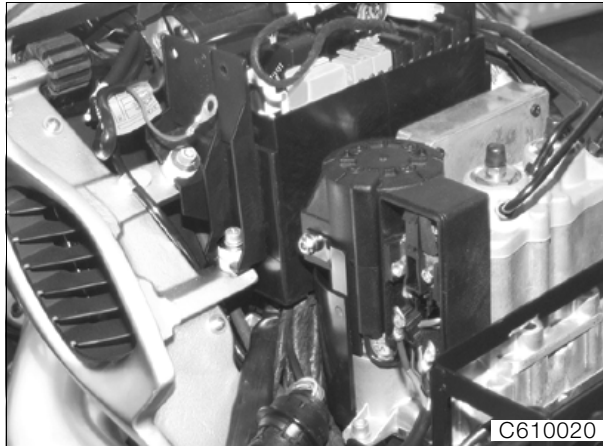

- Detach the central electrical equipment box.
- If necessary, detach the complete wiring harness and remove it with the central electrical equipment box.
- Install by following the above work instructions in the reverse order.



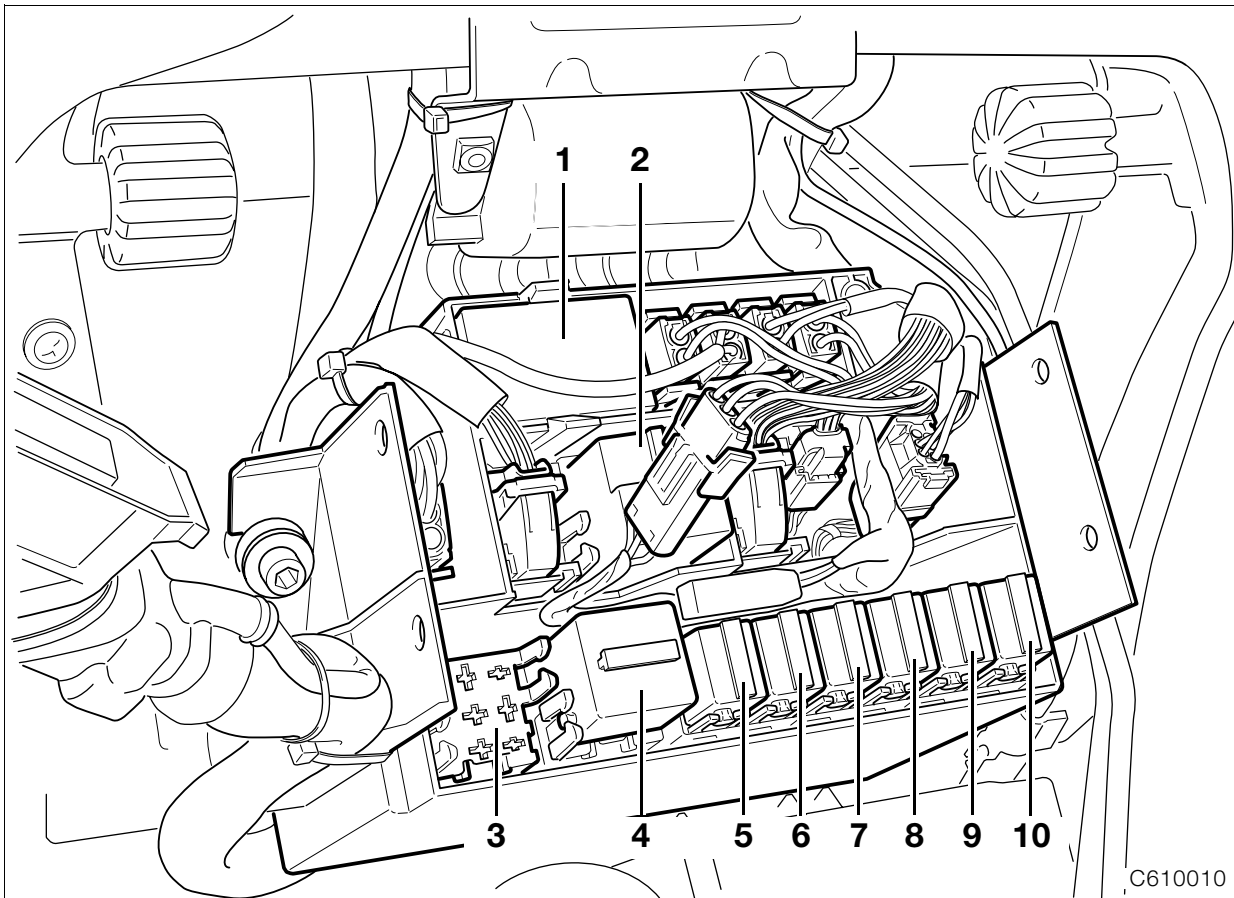

Relay positions (central electrical equipment box)

1. Flasher unit
2. Fuel gauge/display damping
3. Encoding plug for Motronic
4. Starter motor relay
5. Lighting relay
6. ABS warning relay
7. Motronic relay
8. Fuel pump relay
9. Horn relay
10. Load-relief relay
11. Fuse

Connections to fuses:

(No. 1 on left, looking forwards)

- | | |
|-------------------------------------------------------|--------|
| 1. Instrument cluster,
brake and rear lights | 15 Amp |
| 2. Parking light | 15 Amp |
| 3. Flashing turn indicators, clock..... | 15 Amp |
| 4. Power socket | 15 Amp |
| 5. Motronic..... | 15 Amp |
| 6. Fuel pump | 15 Amp |
| 7. Heated handlebar grips | 4 Amp |
| 8. Spare fuse..... | 4 Amp |
| 9. Spare fuse..... | 15 Amp |
| 10. Spare fuse..... | 15 Amp |

Frame wiring harness



Caution:

Use (yellow) galvanized bolts for the ground (earth) connection to the engine.

Screws with unsuitable corrosion proofing can cause the electrical resistance to rise as high as 80 Ω .

Run wiring without kinking and avoid risk of abrasion.

Note the number and position of the cable straps.

- Apply a thin coating of contact grease, e.g. **CENTOPLEX 3 CU** to the central earth (ground) point, which must be cleaned to bright metal first.



Note:

When removing the wiring harness, take out the central electrical equipment box at the same time.



Tightening torque:

Ground (earth) connection to engine 7 Nm



Wiring harness
View from left

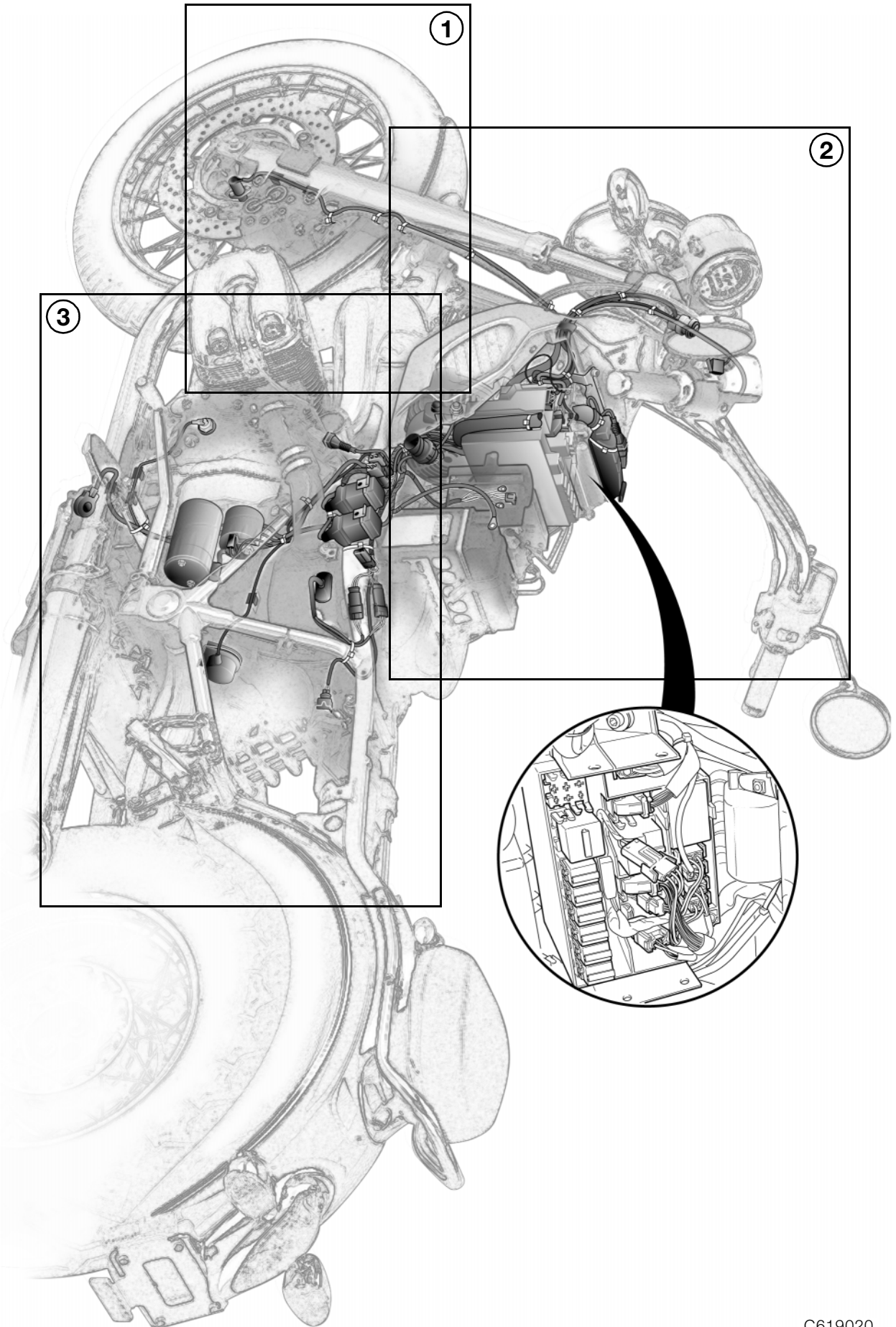

C619020

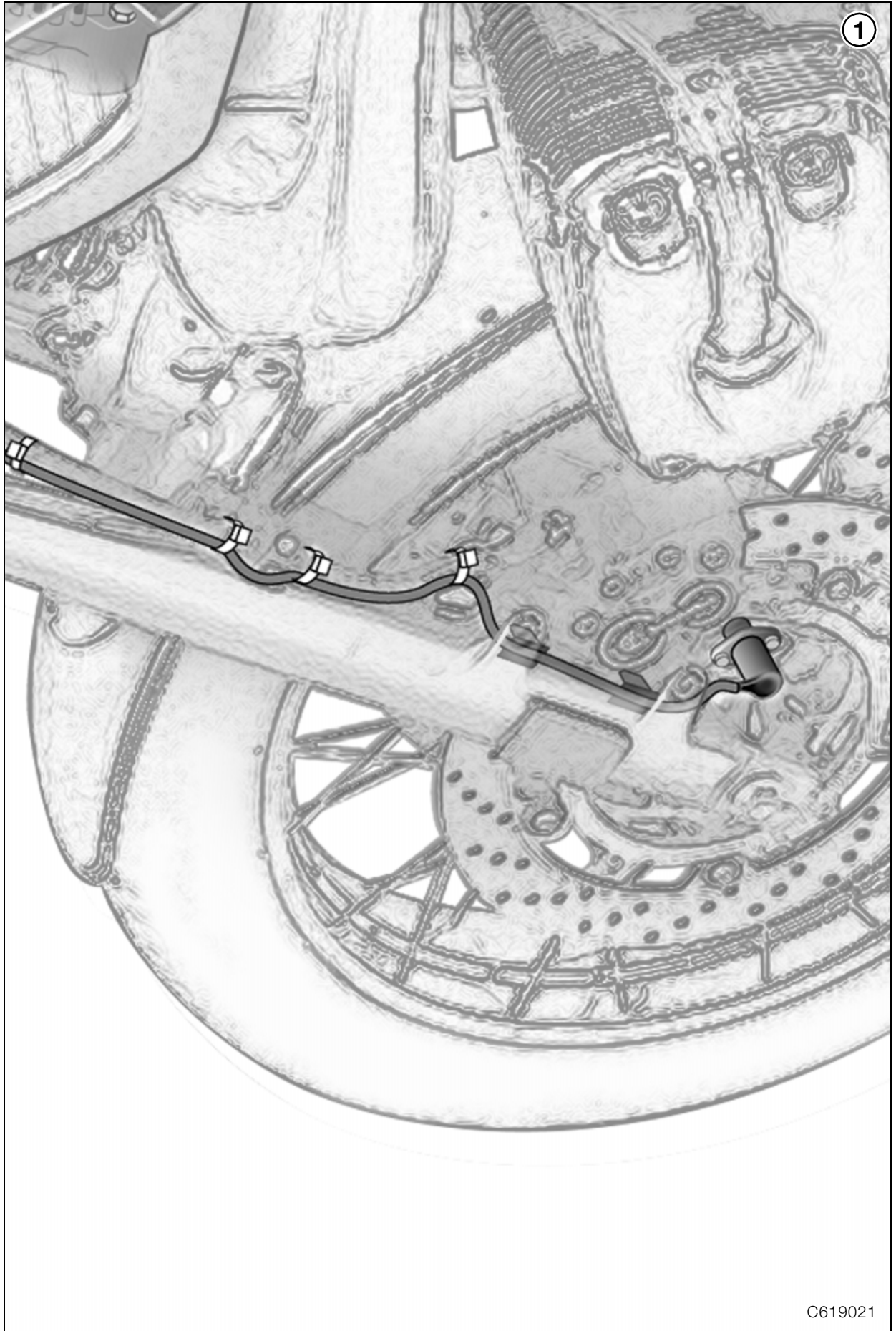

1



C619021

2

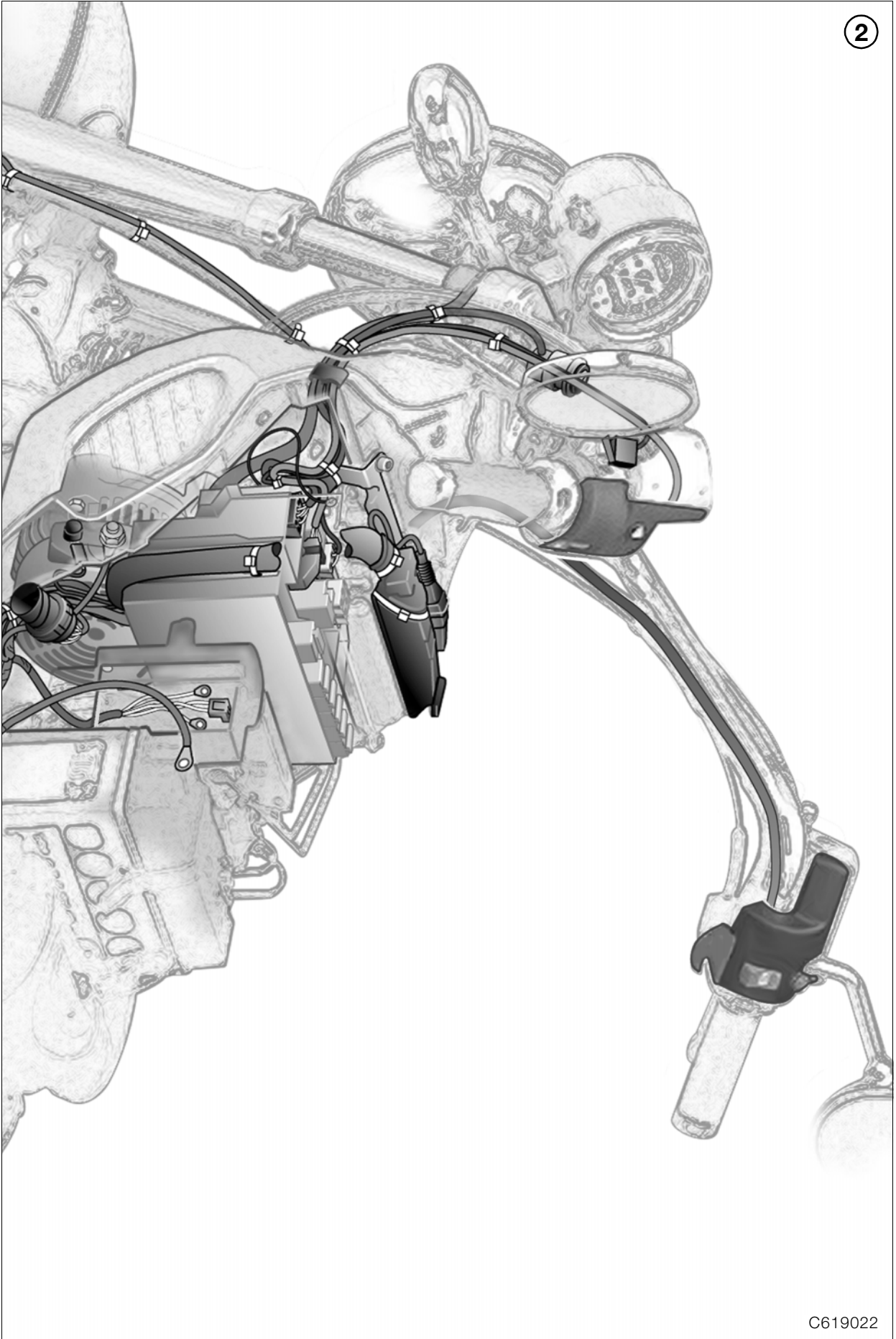

C619022

3

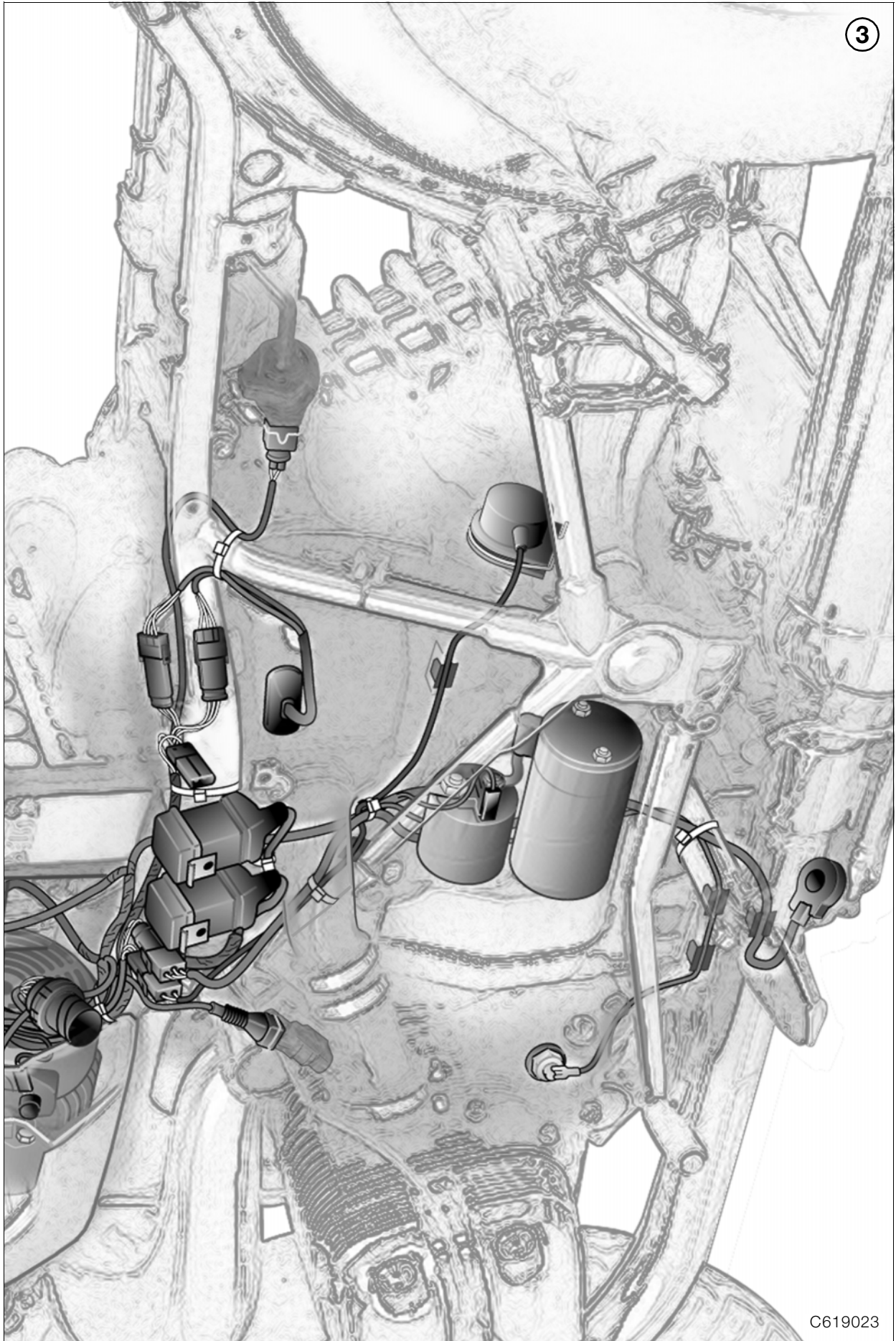

C619023

Wiring harness
View from right

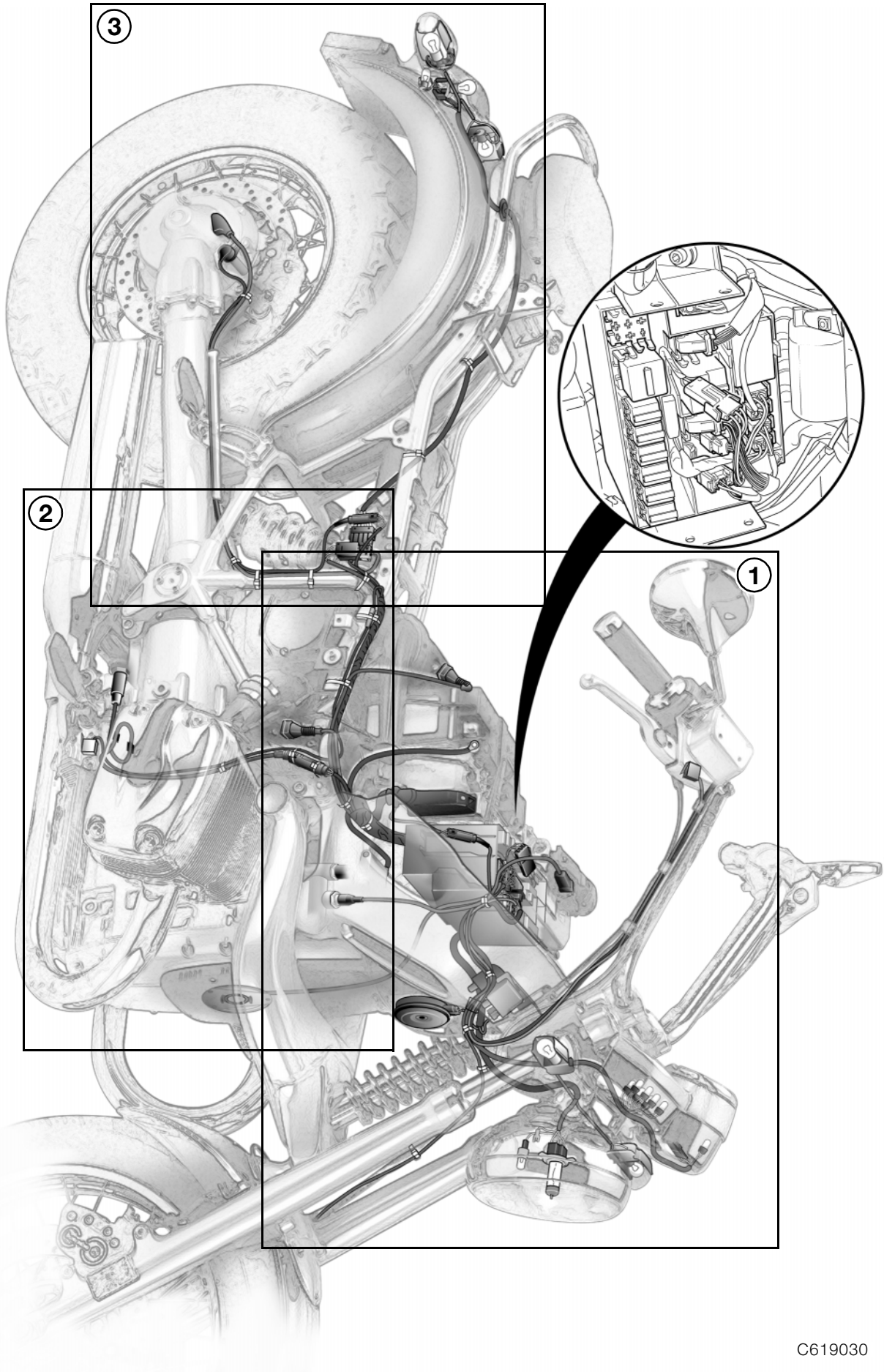

C619030

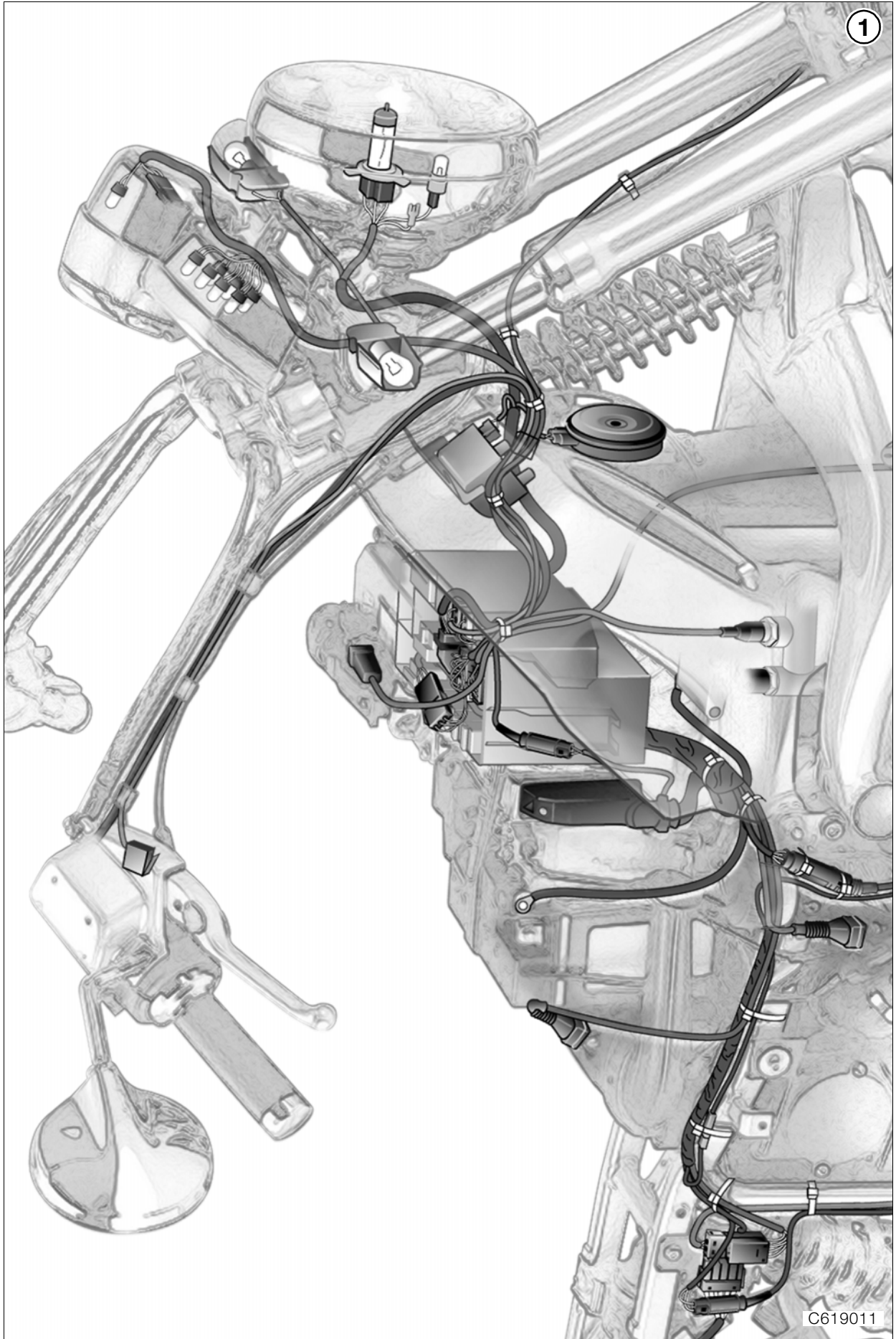

C619011



2



C619012



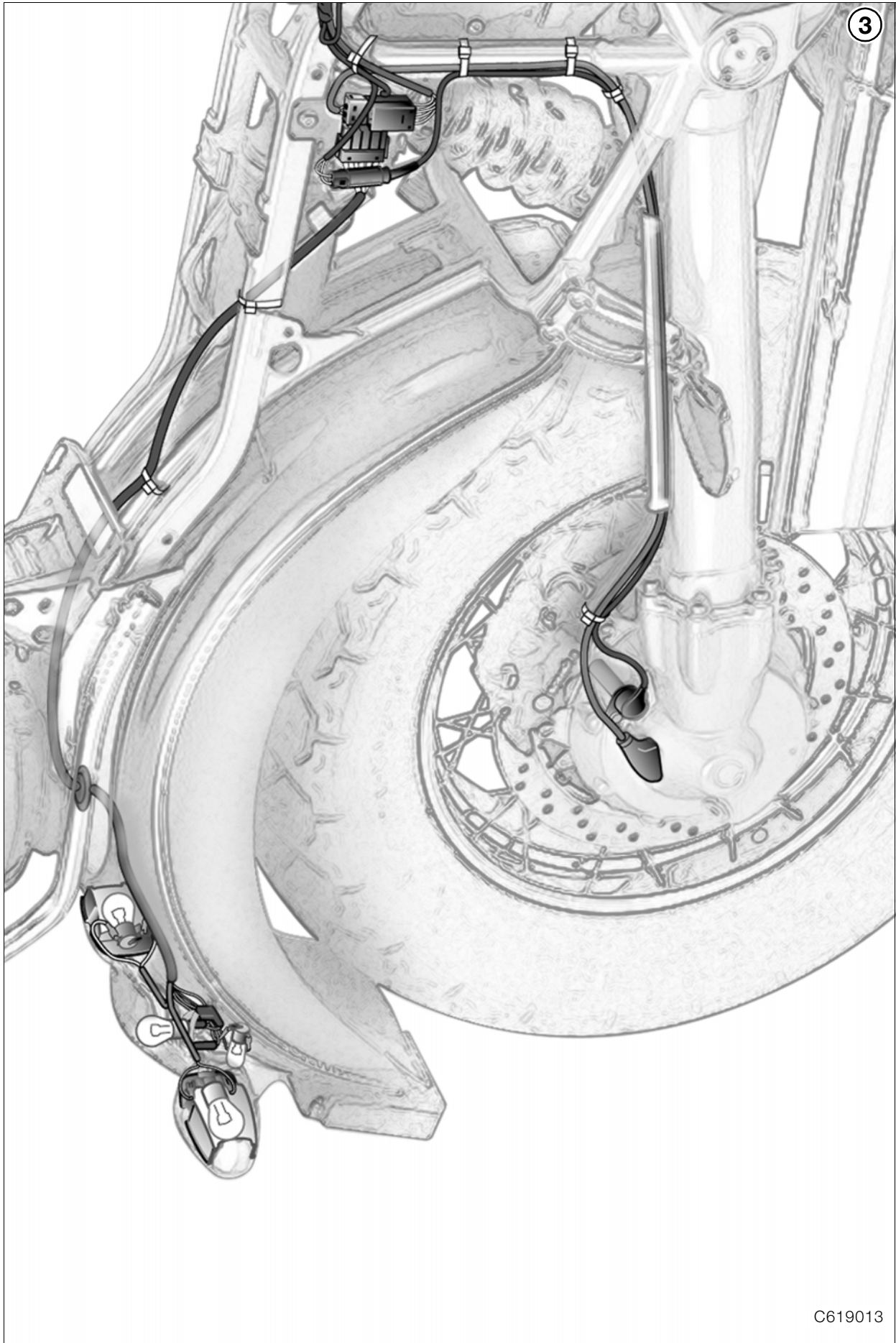

C619013



62 Instruments

Contents

Page

Technical data	3
Removing and installing instrument cluster	5
Dismantling and assembling instrument cluster	5





Technical data	R 850 C	R 1200 C
Instrument cluster		
Instrument lighting	T6.5 12 V 3 W	
Telltale and warning lights turn indicators/others	T6.5 12 V 3 W/1.7 W	





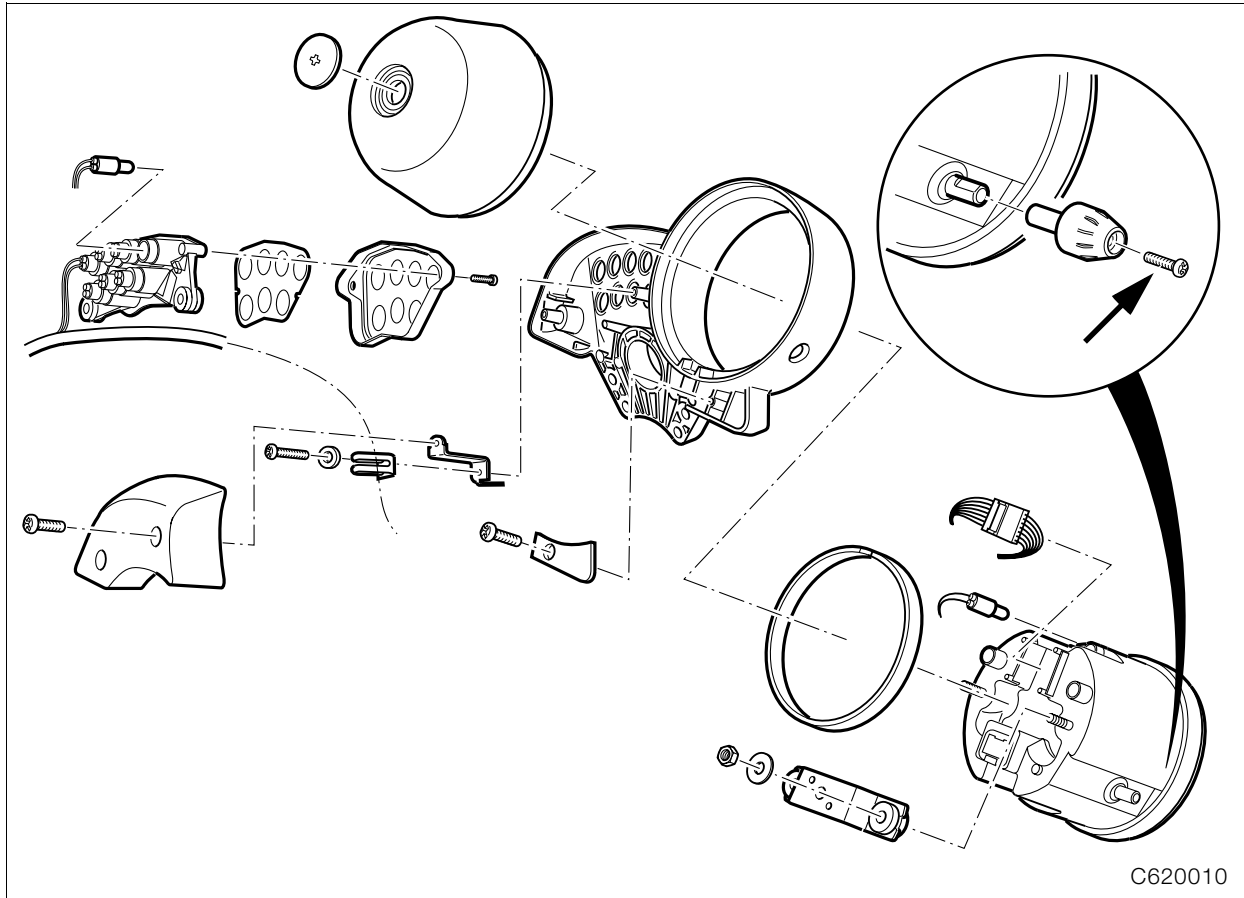

Removing and installing instrument cluster

- Separate the combined instrument plug in the electrical equipment box.

Dismantling and assembling instrument cluster

- To remove the speedometer, take out the screw (arrow) located inside for the trip distance recorder reset knob, and pull off the knob.





63 Lights

Contents

Page

Technical data	3
Removing and installing headlight	5
Adjusting headlight	5



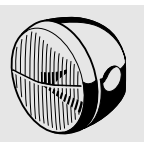

Technical data	R 850 C	R 1200 C
Headlight	circular, with halogen bulb	
Bulbs		
High beam/low beam	H 4 60/55 W halogen, asymmetric	
Parking light	12 V/4 W	
Rear light/brake light	12 V / 5/21 W	
Flashing turn indicator	12 V/21 W	



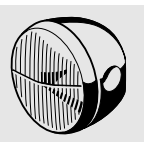

Removing and installing headlight



Caution:

Switch off ignition.

Disconnect earth (ground) lead from battery.

Insulate earth (ground) lead.

Do not touch inner surface of reflector or bulbs with bare hands.

Adjusting headlight

- Correct the beam angle after slightly loosening the headlight mountings.

Adjustment distance:

..... -15 cm (-5.90 in) at a distance of 10 m (32.8 ft)



